

All cirplaced position numbers are recommended spare parts

J233-1000000.

Revision A-01

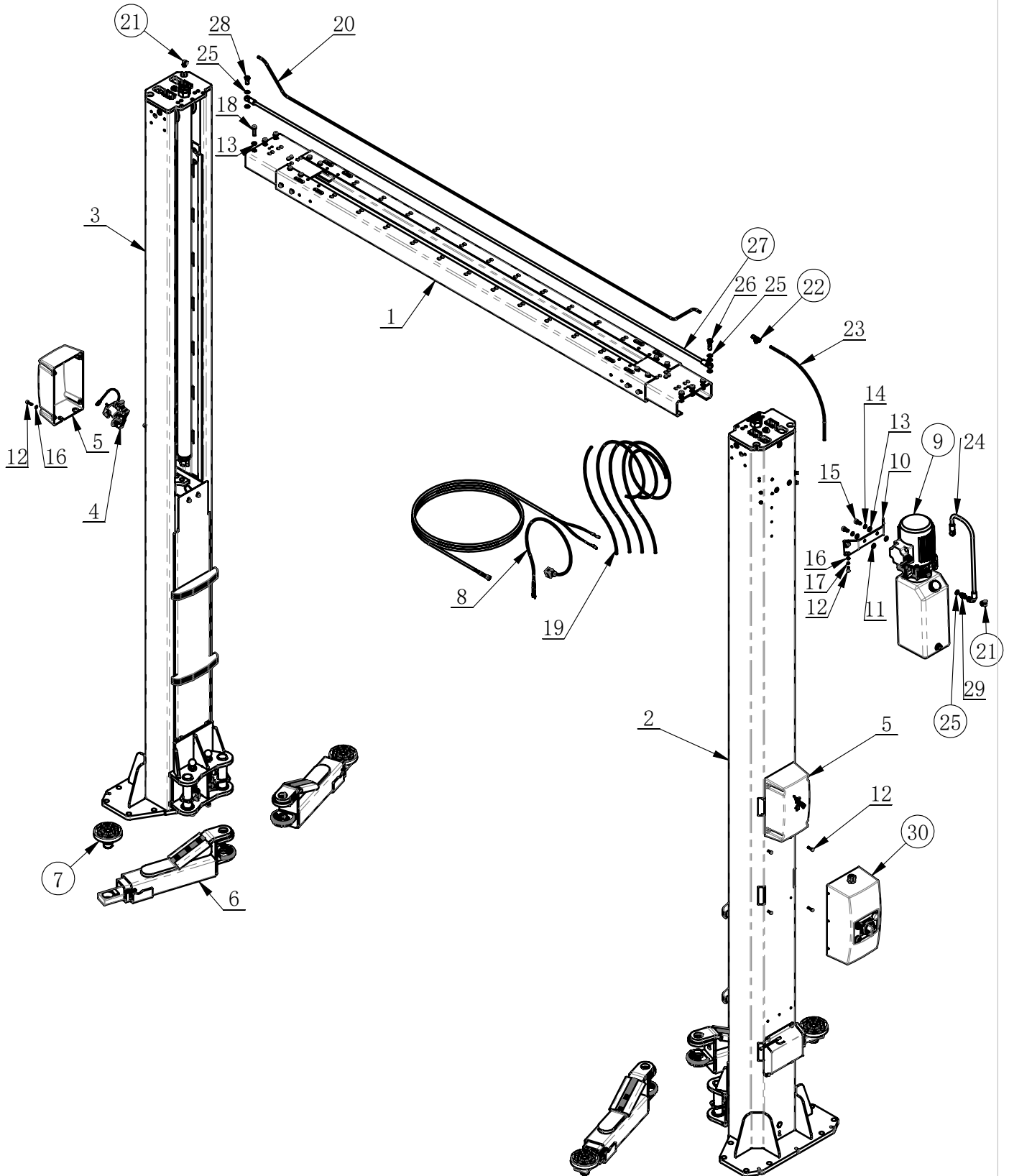

CM245-A Spare Parts

ITEM	PART. No	DESCRIPTION	QT. Y
1	J233-1400000	BEAM KITS	1
2	J233-1100000	MAIN COLUMN PART ASSEMBLY	1
3	J233-1200000	VICE COLUMN PART ASSEMBLY	1
4	J113-1060000A	SAFETY LOCK ASSEMBLY	2
5	J101-1000060	ELECTROMAGNETIC COVER	2
6	J108-1050000	ARM COMPONENTS ONE	4
7	J101-1054000	LIFTING PADS ASSEMBLY	4
8	J201-2101100	HPU SOLENOID VALVE CONNECTION WIRES	1
9	J201-2110000	HPU ASSEMBLY	1
10	J101-1000008	HPU SUPPORT	1
11	J105-1000006	RUBBER DAMPING	4
12	GB70.1-M6×25	INNER HEXA CYLINDRICAL SCREW	16
13	GB95-10	FLAT WASHER	8
14	GB93-10	STANDARD SPRING WASHER	2
15	GB70.1-M10×20	INNER HEXA CYLINDRICAL SCREW	2
16	GB95-6	FLAT WASHER	12
17	GB93-6	STANDARD SPRING WASHER	4
18	GB70.1-M10×40	INNER HEXA CYLINDRICAL SCREW	6
19	J218-1810000	CABLE ASSEMBLY	1
20	J233-1000001	AIR PIPE	1
21	6522 8-1-4	MALE ELBOW	2
22	6432 8-1-4	T-JOINT	1
23	J201-1700002	AIR PIPE	1
24	J101-1141000	SUPPRESSED RUBBER HOSE	1
25	JB982-13	COMBINED PAD	6
26	J201-1600001	BRITISH MADE HINGE BOLTS	1
27	J233-1010000	CONNECTOR RUBBER HOSE	1
28	J101-1140005	BRITISH MADE HINGE BOLTS	1
29	J301-1700001	CONNECTOR	1
30	J233-1800000	ELECTRIC CONTROL SYSTEM	1

All cirplaced position numbers are recommended spare parts

J233-1100000.

Revision A-01

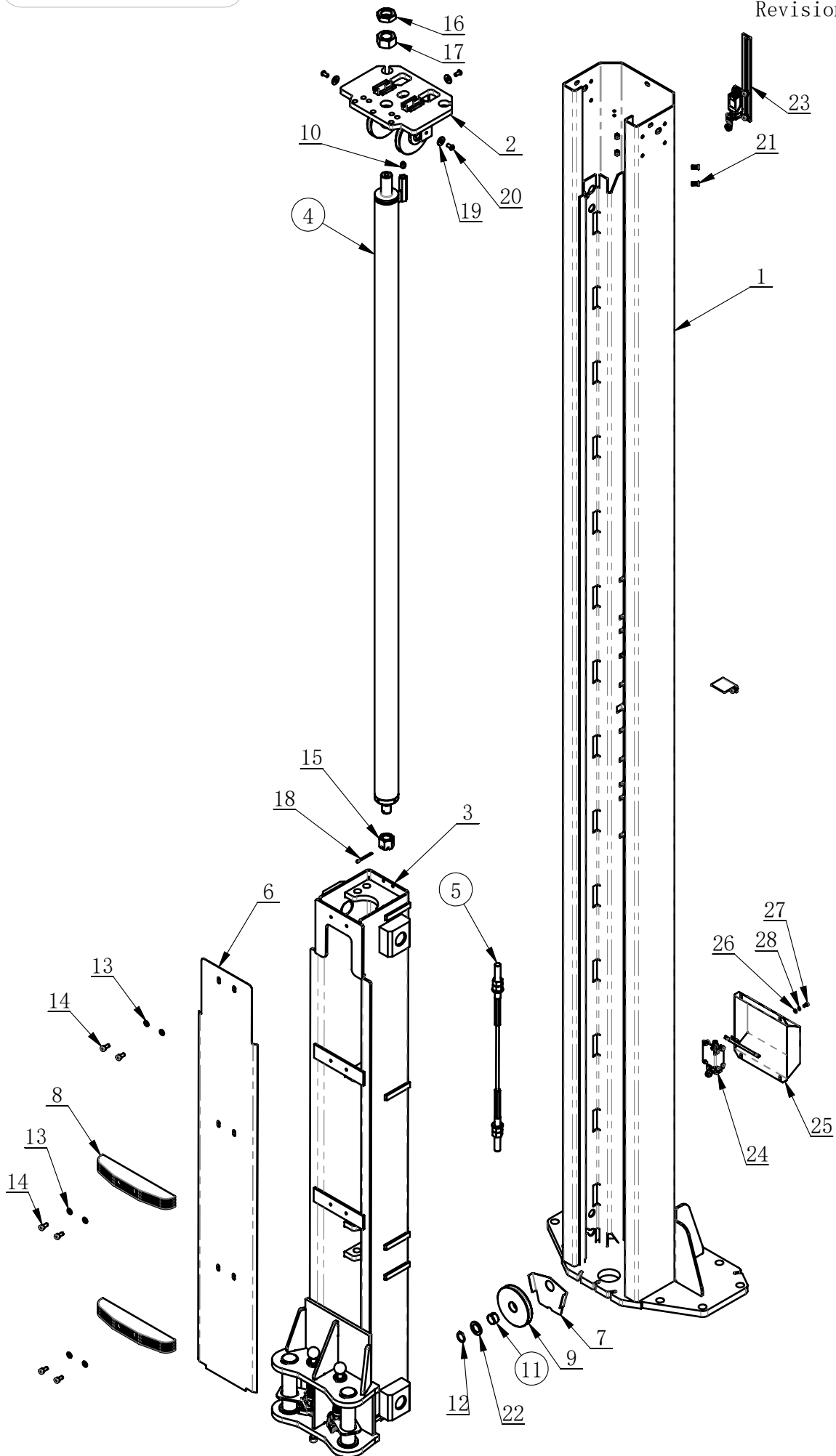

ITEM	PART. No	DESCRIPTION	QT. Y
1	J233-1110000	Upright post	1
2	J201-1D10000	UPPER COVER PART ASSEMBLY	1
3	J233-1120000	TOP CONNECTION CARRIGE ASSEMBLY	1
4	J201-1500000	TOP CONNECTION CYLINDER	1
5	J233-1101000	SYNCHRONOUS ROPE	1
6	J233-1100001	BARRIER BOARD	1
7	J201-1000004	CARRIGE PROTECTIVE COVER	1
8	J101-1000003	PROTECTIVE RUBBER	2
9	J101-1080002	SYNCHRONOUS PULLEY	1
10	J101-1143000	HOSE PARACHUTE VALVE	1
11	GB12613-25X28X15	COILING AXLE SLEEVE	1
12	GB894. 2-25	SHAFT ELATIC RETAINING RING B-TYPE	1
13	GB95-8	FLAT WASHER	6
14	GB70. 1-M8×16	INNER HEXA CYLINDRICAL SCREW	6
15	GB9457-M24×2	1-TYPE HEXA SLOTTED NUT B-GRADE	1
16	GB6173-M30×2. 0	HEXA THIN NUT	1
17	GB6171-M30×2	1-TYPE HEXA NUT	1
18	GB91-5×45	SLOTTED PIN	1
19	GB96. 2-8	LARGE WASHER C GRADE	3
20	GB70. 2-M8×16	INNER HEXA CYLINDRICAL ROUND HEAD SCREW	3
21	GB17880. 5-M6×18	FLAT HEXA RIVETTED NUT	4
22	J201-1D00001	PAD	1
23	J218-1500000	Upper limit	1
24	J218-1600000	SAFT SWITCH ASSEMBLY	1
25	J218-1000001	Lid	1
26	GB95-5	FLAT WASHER	4
27	GB70. 1-M5×10	INNER HEXA CYLINDRICAL SCREW	4
28	GB93-5	STANDARD SPRING WASHER	4

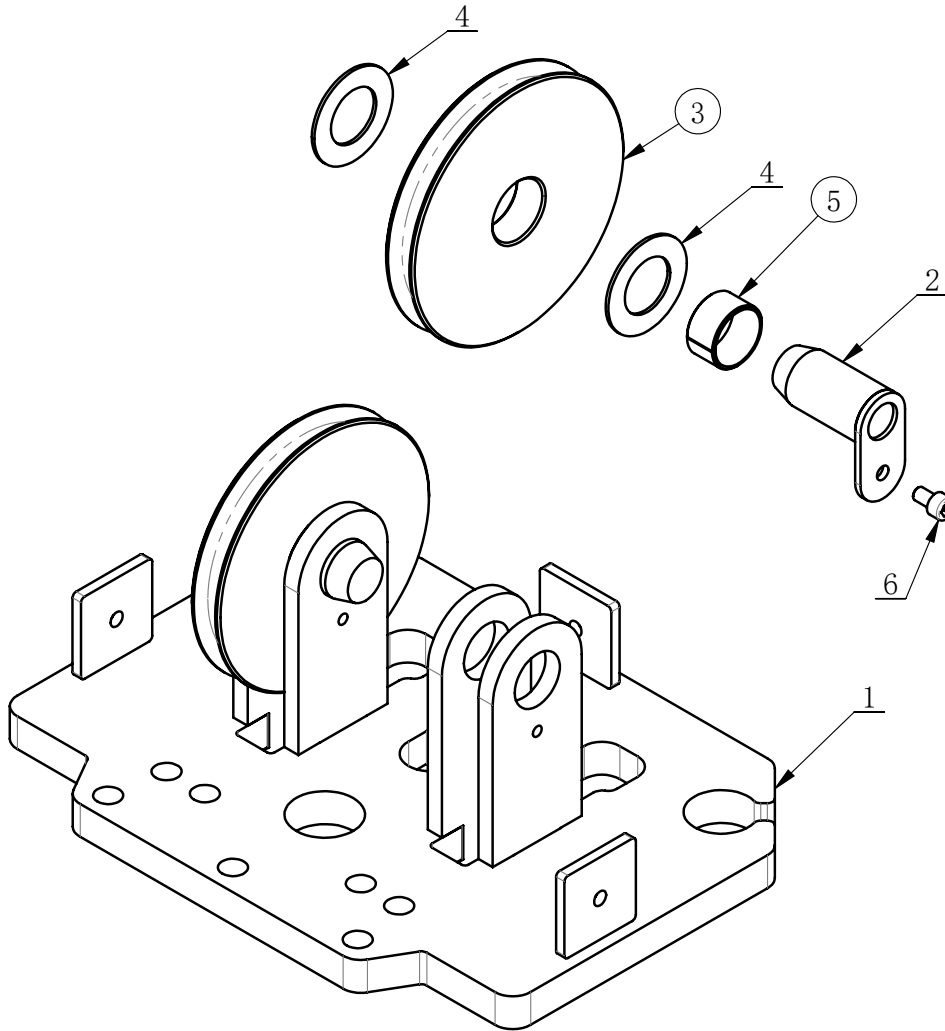

ITEM	PART. No	DESCRIPTION	QT. Y
1	J201-1430000	THE SWINGING RING OF WIRE PULLEY	1
2	J201-1460000	SPLINE DABBER	2
3	J101-1080002	SYNCHRONOUS PULLEY	2
4	J101-1080004	D25.5 PAD	4
5	GB12613-25X28X15	COILING AXLE SLEEVE	2
6	GB70.1-M6×10	INNER HEXA CYLINDRICAL SCREW	2

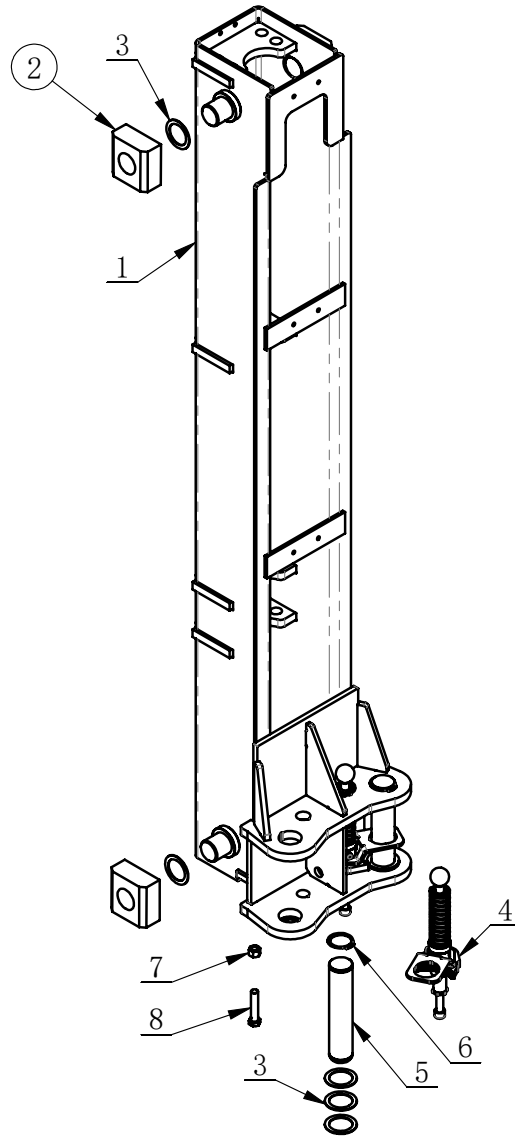

ITEM	PART. No	DESCRIPTION	QT. Y
1	J233-1121000	TOP CONNECTION LIFTER	1
2	J101-1040001	NYLON SLIDING BLOCK	4
3	J101-1040002	ADJUSTABLE PAD OF SLIDING BLOCK	10
4	J213-1042000	LOCK SHAFT ASSEMBLY	2
5	J108-1040011	ARM SHAFT	2
6	GB894.2-40	SHAFT ELATIC RETAINING RING B-TYPE	4
7	GB41-M12	HEXANGULAR NUT	2
8	GB5783-M12×60	HEXANGULAR BOLT	2

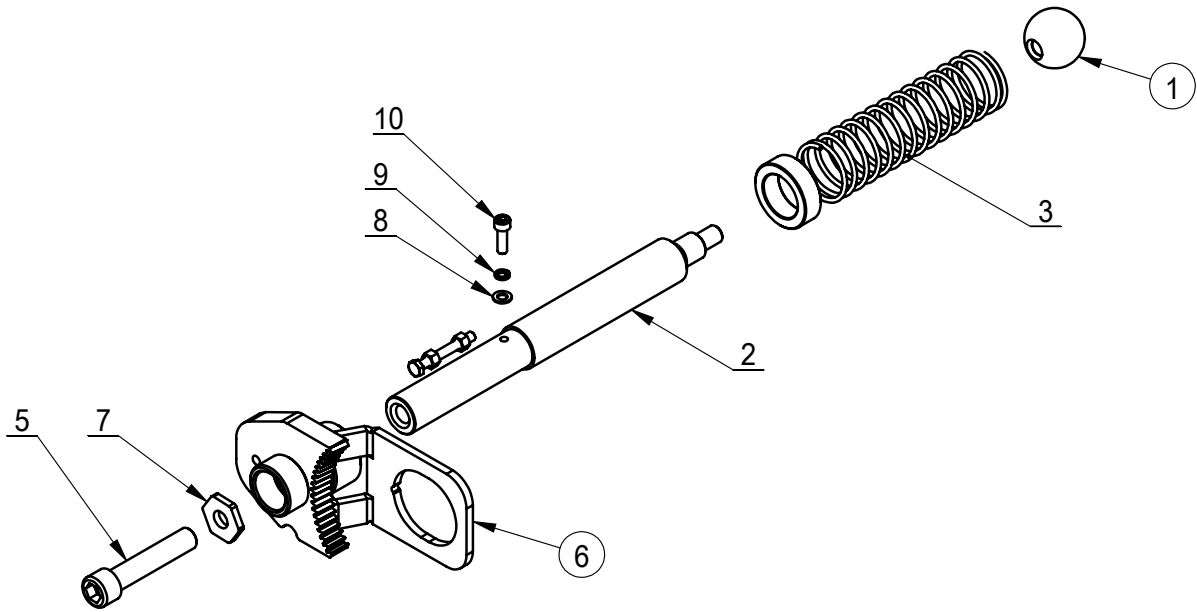

ITEM	PART.No	DESCRIPTION	QT.Y
1	MH-12-1360011	HAND SHANK	1
2	J108-1110001	LOCK SHAFT	1
3	J101-1110003	COMPRESSED SPRING OF GEAR LOCK	1
4	J101-1110004	BUSHING	1
5	GB70.1-M12×60	INNER HEXA CYLINDRICAL SCREW	1
6	J108-1110100	LOCKING GEAR	1
7	J108-1110002	LOCK NUT	1
8	GB95-5	FLAT WASHER	1
9	GB93-5	STANDARD SPRING WASHER	1
10	GB70.1-M5×16	INNER HEXA CYLINDRICAL SCREW	1
11	GB5781-M5×40	HEXANGULAR BOLT	1
12	GB41-M5	HEXANGULAR NUT	2

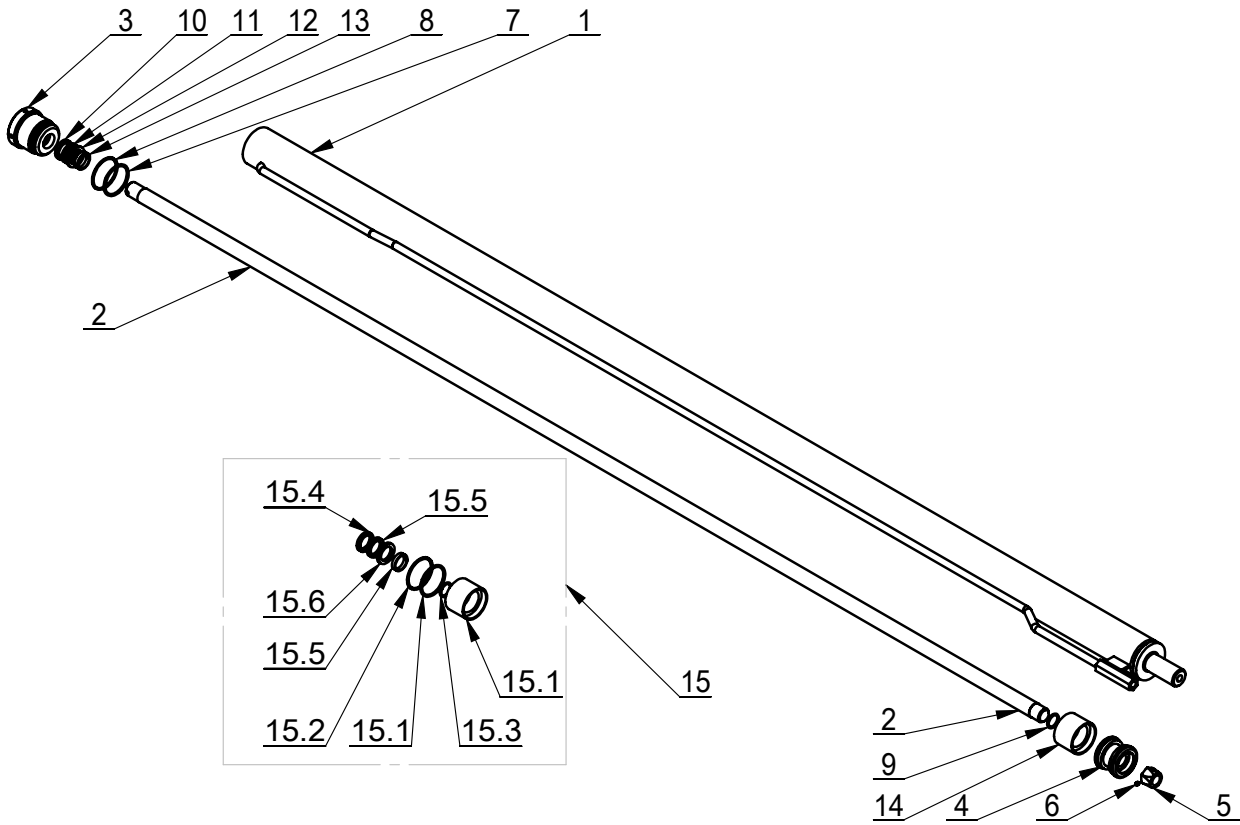

ITEM	PART NUMBER	Description.	QT/Y
1	J201-1500000-01-A	CYLINDER TUBE	1
2	J201-1500000-02	PISTON ROD	1
3	J201-1500000-03	END CAP	1
4	J201-1500000-04	PISTON	1
5	M18×1.5	NUT	1
6	GB71-M5×6	SCREW	1
7	GB1235-55×3.1	O-RING	1
8	J201-1500000-05	RETAINING ROD	1
9	GB 3452.1 20x2.65-G	O-RING	1
10	4631000	DUST RING	1
11	4610100	SEAL RING	1
12	GSJ0250	STERLING	1
13	PFC 25×6×2	GUIDE BELE	1
14	5000910	COMBINATION SEAL	1
15	J201-1500000MFJ	SEALING RING SET	1
15.1	GB1235-55×3.1	O-RING	1
15.2	J201-1500000-05	RETAINING ROD	1
15.3	GB 3452.1 20x2.65-G	O-RING	1
15.4	4631000	DUST RING	1
15.5	4610100	SEAL RING	1
15.6	GSJ0250	STERLING	1
15.7	PFC 25×6×2	GUIDE BELE	1
15.8	5000910	COMBINATION SEAL	1

J218-1500000.

Revision A-01

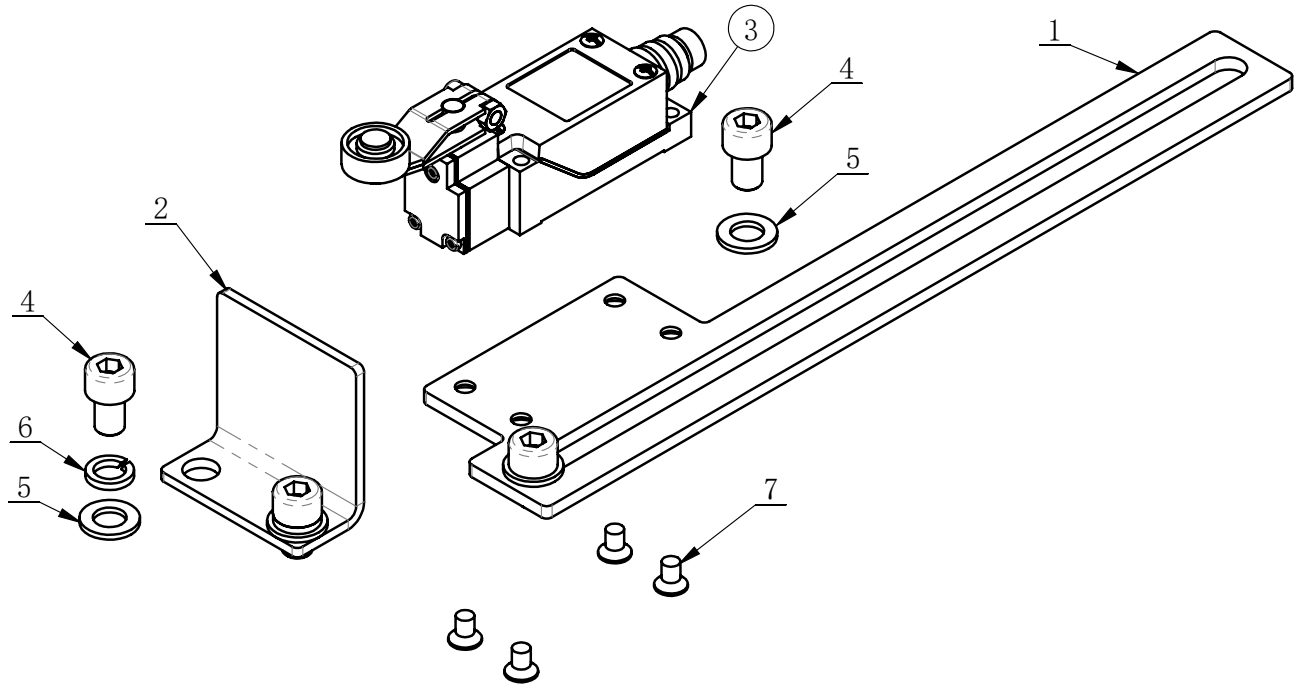

ITEM	PART. No	DESCRIPTION	QT. Y
1	J218-1500001	Bracket	1
2	J218-1500002	Baffle	1
3	J108-1002011	Travel switch	1
4	GB70.1-M8×12	INNER HEXA CYLINDRICAL SCREW	4
5	GB95-8	FLAT WASHER	4
6	GB93-8	STANDARD SPRING WASHER	2
7	GB819.1-M5×8-H	CROSS COUNTERSUNK SCREW STEEL 4.8 GRADE	4

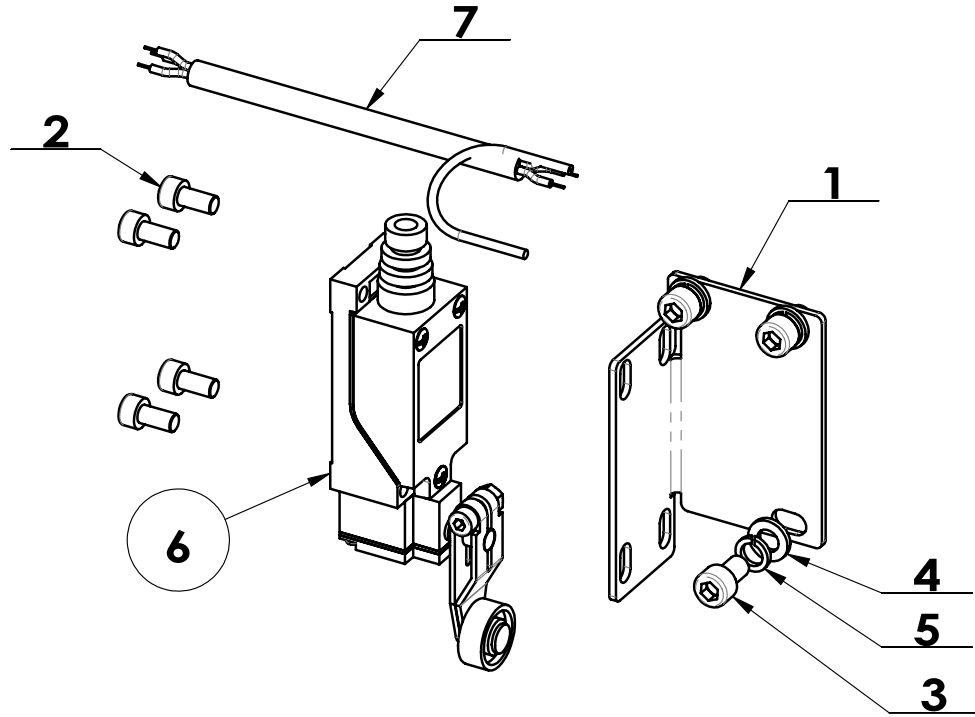

ITEM	PART. No	DESCRIPTION	QT. Y
1	J108-1002001	Bracket	1
2	GB70. 1-M5×10	INNER HEXA CYLINDRICAL SCREW	4
3	GB70. 1-M6×10	INNER HEXA CYLINDRICAL SCREW	3
4	GB95-6	FLAT WASHER	3
5	GB93-6	STANDARD SPRING WASHER	3
6	J108-1002011	Travel switch	1
7	J218-1810002	Travel switch wire	1

J233-1200000.

Revision A-01

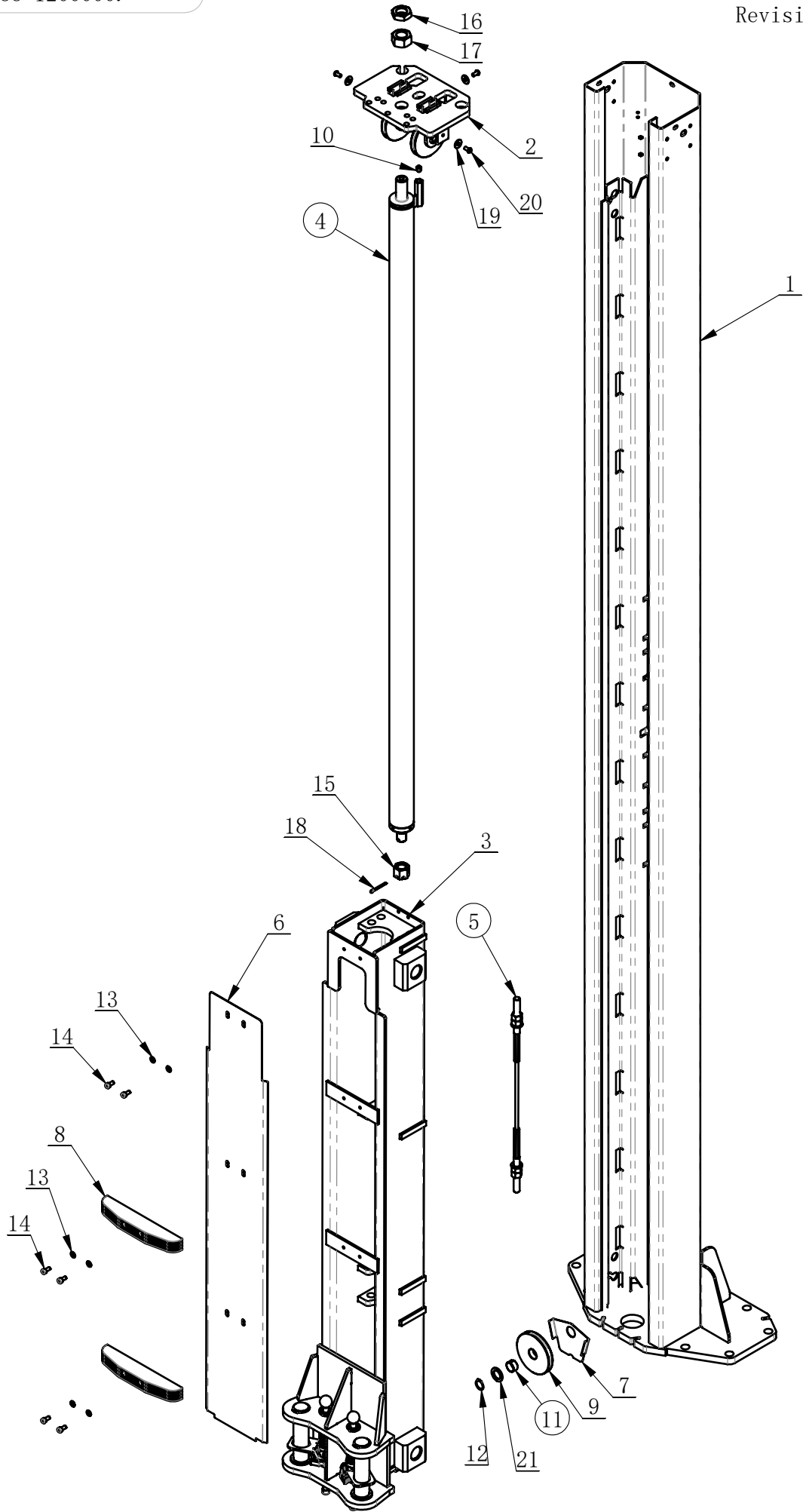

ITEM	PART. No	DESCRIPTION	QT. Y
1	J233-1110000	Upright post	1
2	J201-1D10000	UPPER COVER PART ASSEMBLY	1
3	J233-1120000	TOP CONNECTION CARRIGE ASSEMBLY	1
4	J201-1500000	TOP CONNECTION CYLINDER	1
5	J233-1101000	SYNCHRONOUS ROPE	1
6	J233-1100001	BARRIER BOARD	1
7	J201-1000004	CARRIGE PROTECTIVE COVER	1
8	J101-1000003	PROTECTIVE RUBBER	2
9	J101-1080002	SYNCHRONOUS PULLEY	1
10	J101-1143000	HOSE PARACHUTE VALVE	1
11	GB12613-25X28X15	COILING AXLE SLEEVE	1
12	GB894. 2-25	SHAFT ELATIC RETAINING RING B-TYPE	1
13	GB95-8	FLAT WASHER	6
14	GB70. 1-M8×16	INNER HEXA CYLINDRICAL SCREW	6
15	GB9457-M24×2	1-TYPE HEXA SLOTTED NUT B-GRADE	1
16	GB6173-M30×2. 0	HEXA THIN NUT	1
17	GB6171-M30×2	1-TYPE HEXA NUT	1
18	GB91-5×45	SLOTTED PIN	1
19	GB96. 2-8	LARGE WASHER C GRADE	3
20	GB70. 2-M8×16	INNER HEXA CYLINDRICAL ROUND HEAD SCREW	3
21	J201-1D00001	PAD	1

J233-1400000.

Revision A-01

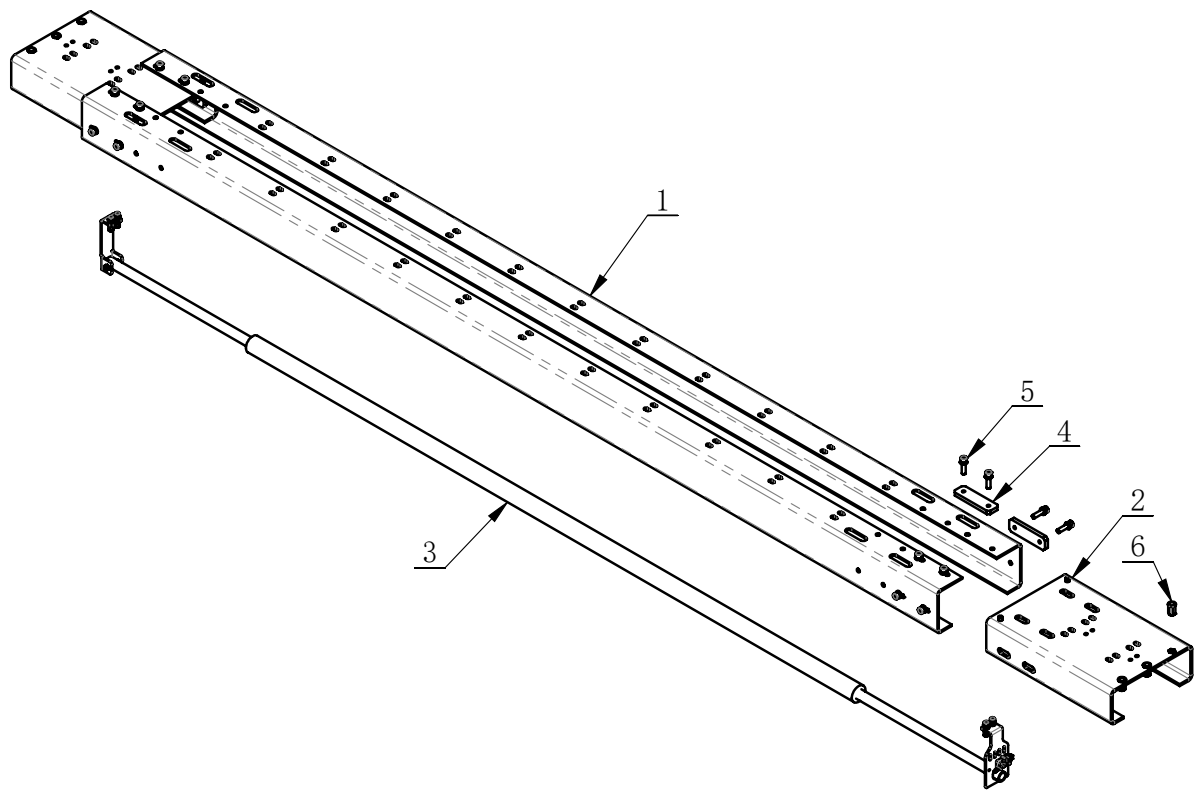

ITEM	PART. No	DESCRIPTION	QT. Y
1	J233-1400001	beam	2
2	J233-1410000	Connecting seat	2
3	J233-1450000	LIFT LIMIT CONTROL ASSEMBLY	1
4	J201-1400003	REAR LINING BOARD	8
5	GB9074-M8×25	COMBINATION SCREW	16
6	GB17880. 5-M10×22.5	FLAT HEXA RIVETTED NUT	6

J233-1450000.

Revision A-01

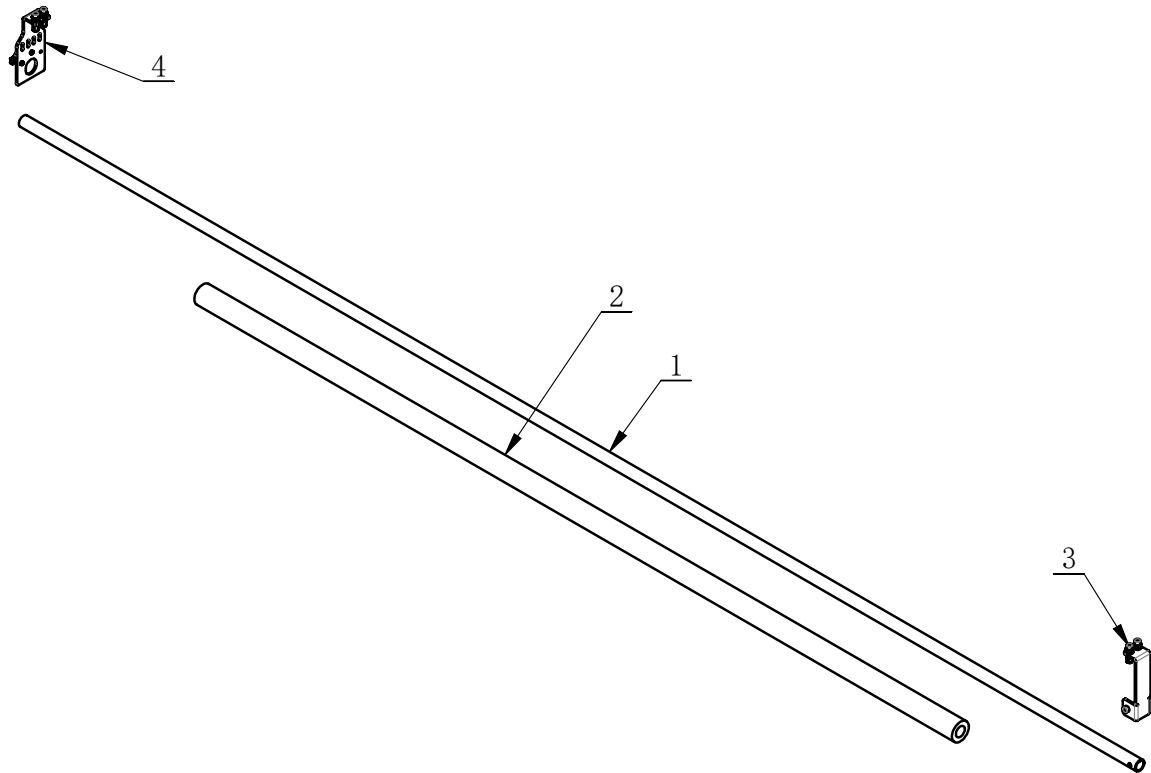

ITEM	PART. No	DESCRIPTION	QT. Y
1	J233-1450001	TOUCH ROD	1
2	J201-1450003	HEAT PRESERVATION COTTON TUBE	1
3	J201-1451000	TOUCH ROD SUPPORT	1
4	J201-1452000	TOUCH ROD SWITCH BASE	1

J201-1451000.

Revision A-03

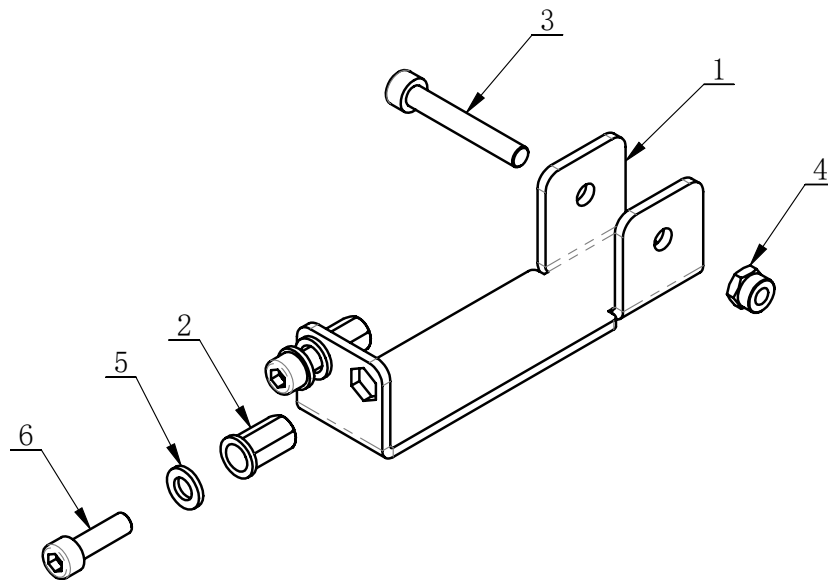

ITEM	PART. No	DESCRIPTION	QT. Y
1	J201-1451001	TOUCH ROD SUPPORT BOARD	1
2	GB17880. 5-M6×16. 5	FLAT HEXA RIVETTED NUT	2
3	GB70. 1-M6×40	INNER HEXA CYLINDRICAL SCREW	1
4	GB889. 1-M6	1-TYPE PREVAILING TORQUE TYPE HEXAGON LOCK NUT	1
5	GB95-6	FLAT WASHER	2
6	GB70. 1-M6×20	INNER HEXA CYLINDRICAL SCREW	2

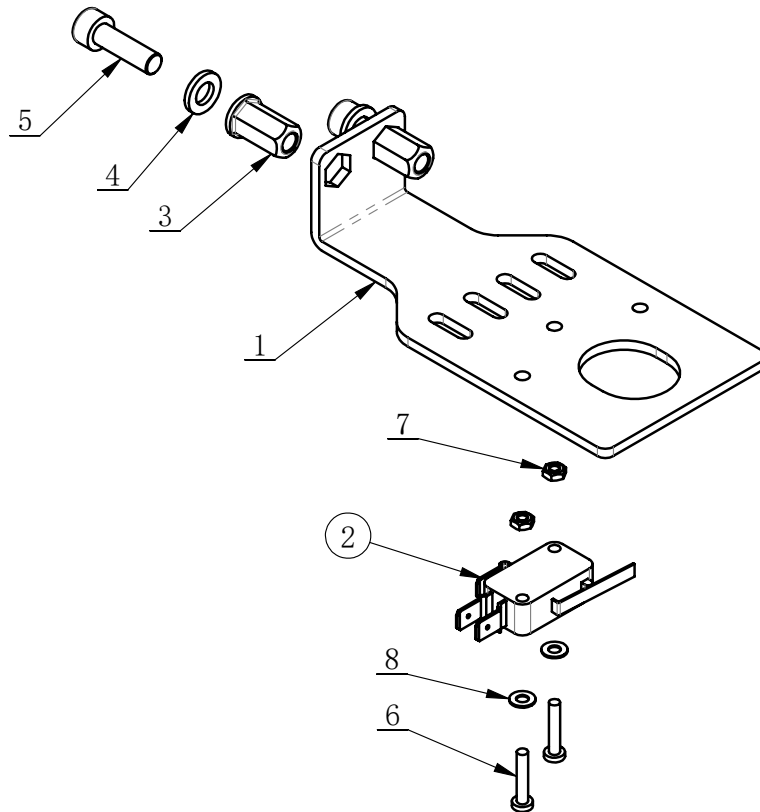

ITEM	PART. No	DESCRIPTION	QT. Y
1	J201-1452001	TOUCH ROD SWITCH BASE BOARD	1
2	J101-1150002	MICRO SWITCH	1
3	GB17880. 5-M6×16. 5	FLAT HEXA RIVETTED NUT	2
4	GB95-6	FLAT WASHER	2
5	GB70. 1-M6×20	INNER HEXA CYLINDRICAL SCREW	2
6	GB818-M3×16-H	CROSS PANHEAD SCREW	2
7	GB6170-M3	HEXANGULAR NUT 1-TYPE	2
8	GB95-3	FLAT WASHER	2

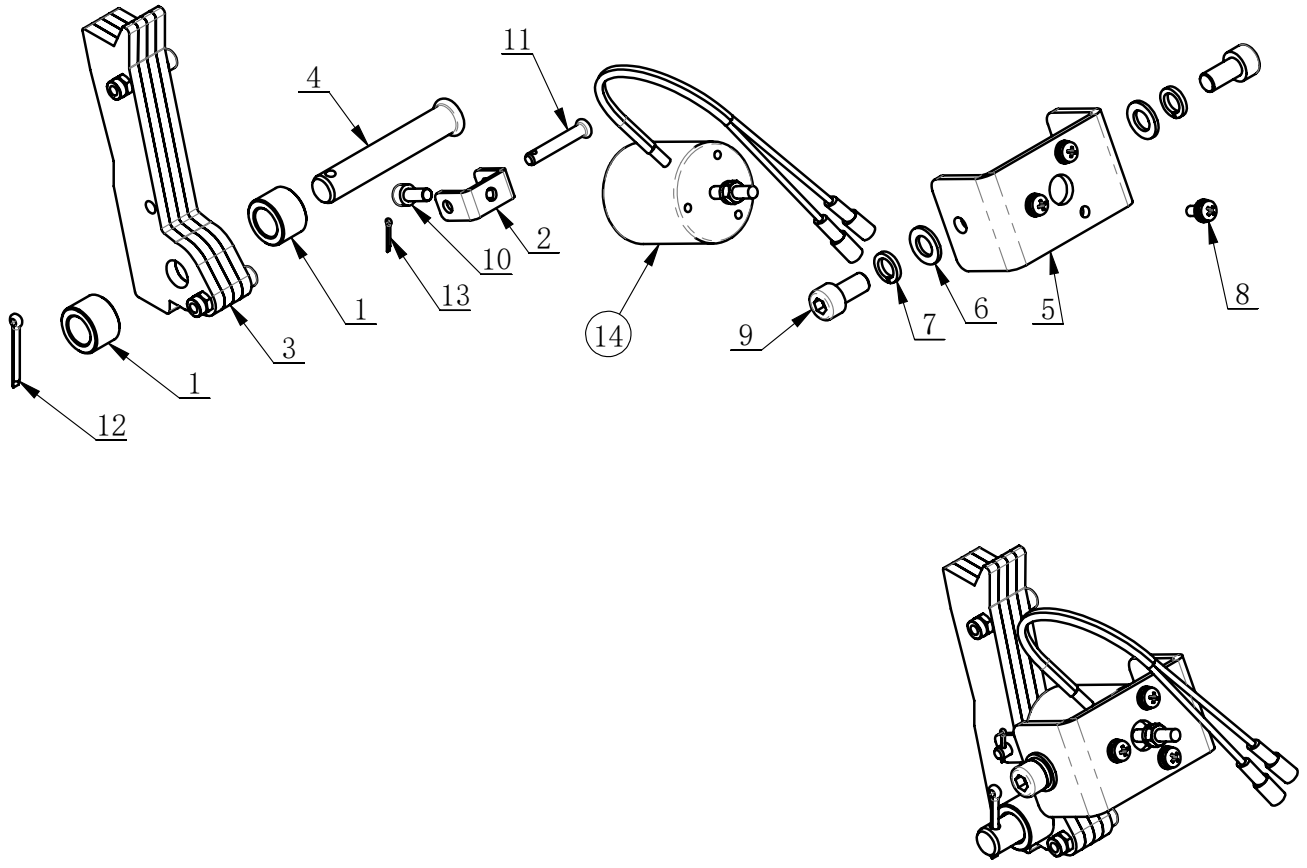

ITEM	PART. No	DESCRIPTION	QT. Y
1	J113-1060002	LOCK PLATE SPACER	2
2	J113-1060004	ELECTROMAGNETIC U SHAPE FRAME	1
3	J113-1062000	LOCK SHEET ASSEMBLY	1
4	GB882-12×70	PIN SHAFT	1
5	J113-1063004	ELECTROMAGNETIC BENDING PLATE	1
6	GB95-8	FLAT WASHER	2
7	GB93-8	STANDARD SPRING WASHER	2
8	GB9074. 4-M4x10	COMBINATION SCREW	3
9	GB70. 1-M8×16	INNER HEXA CYLINDRICAL SCREW	2
10	GB70. 1-M5×12	INNER HEXA CYLINDRICAL SCREW	1
11	GB882-5×30	PIN SHAFT	1
12	GB91-3. 2×25	SLOTTED PIN	1
13	GB91-1. 6×10	SLOTTED PIN	1
14	J113-1060003	TRACTION ELECTROMAGNETIC	1

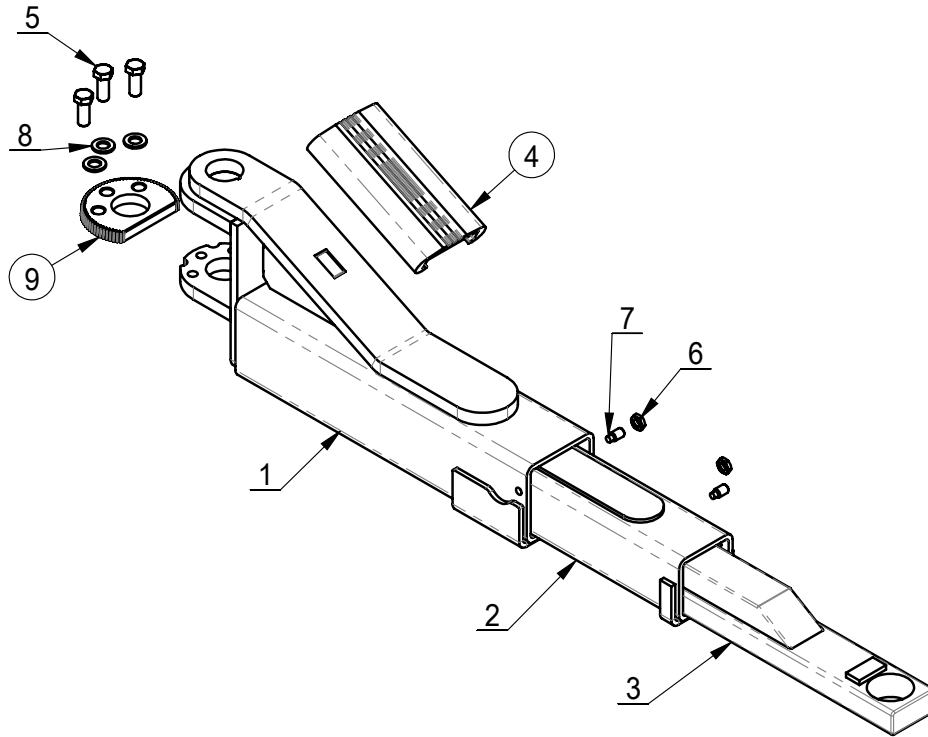

ITEM	PART.No	DESCRIPTION	QT.Y
1	J108-1051000	STEP ARM	1
2	J108-1052000	STEP ARM	1
3	J108-1053000	LAST STEP ARM	1
4	J101-1050002	PROTECTIVE RUBBER	1
5	GB5783-M12×30	HEXANGULAR BOLT	3
6	GB6172.1-M10	HEXANGULAR THIN NUT	2
7	GB79-M10×20	INNER HEXA CYLINDRICAL TERMINUS SET SCREW	2
8	GB95-12	FLAT WASHER	3
9	J108-1050001.	LOCK GEAR	1

J201-2110000

Revision A-03

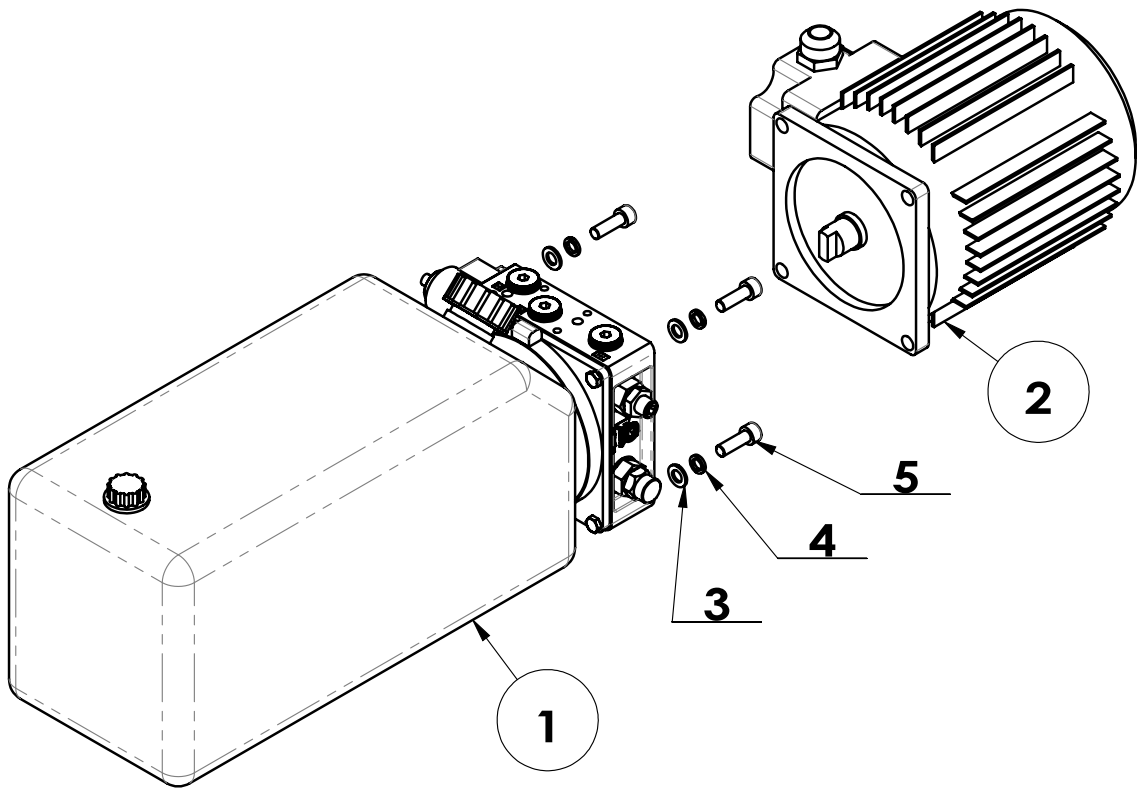

J201-2110000 (400V/3P)			
ITEM	PART. No	DESCRIPTION	QT. Y
1	J201-2611000	Hydraulic pump unit	1
2	J101-1131000	Electro Motor	1
3	GB95-8	FLAT WASHER	4
4	GB93-8	STANDARD SPRING WASHER	4
5	GB70.1-M8×25	INNER HEXA CYLINDRICAL SCREW	4

J201-2130000 (230V/50Hz/1P)			
ITEM	PART. No	DESCRIPTION	QT. Y
1	J101-1181000	Hydraulic pump unit	1
2	J101-1501001	Electro Motor	1

J201-2160000 (230V/60Hz/1P)			
ITEM	PART. No	DESCRIPTION	QT. Y
1	J101-1181000	Hydraulic pump unit	1
2	J101-1501002	Electro Motor	1

J201-2611000

Revision A-04

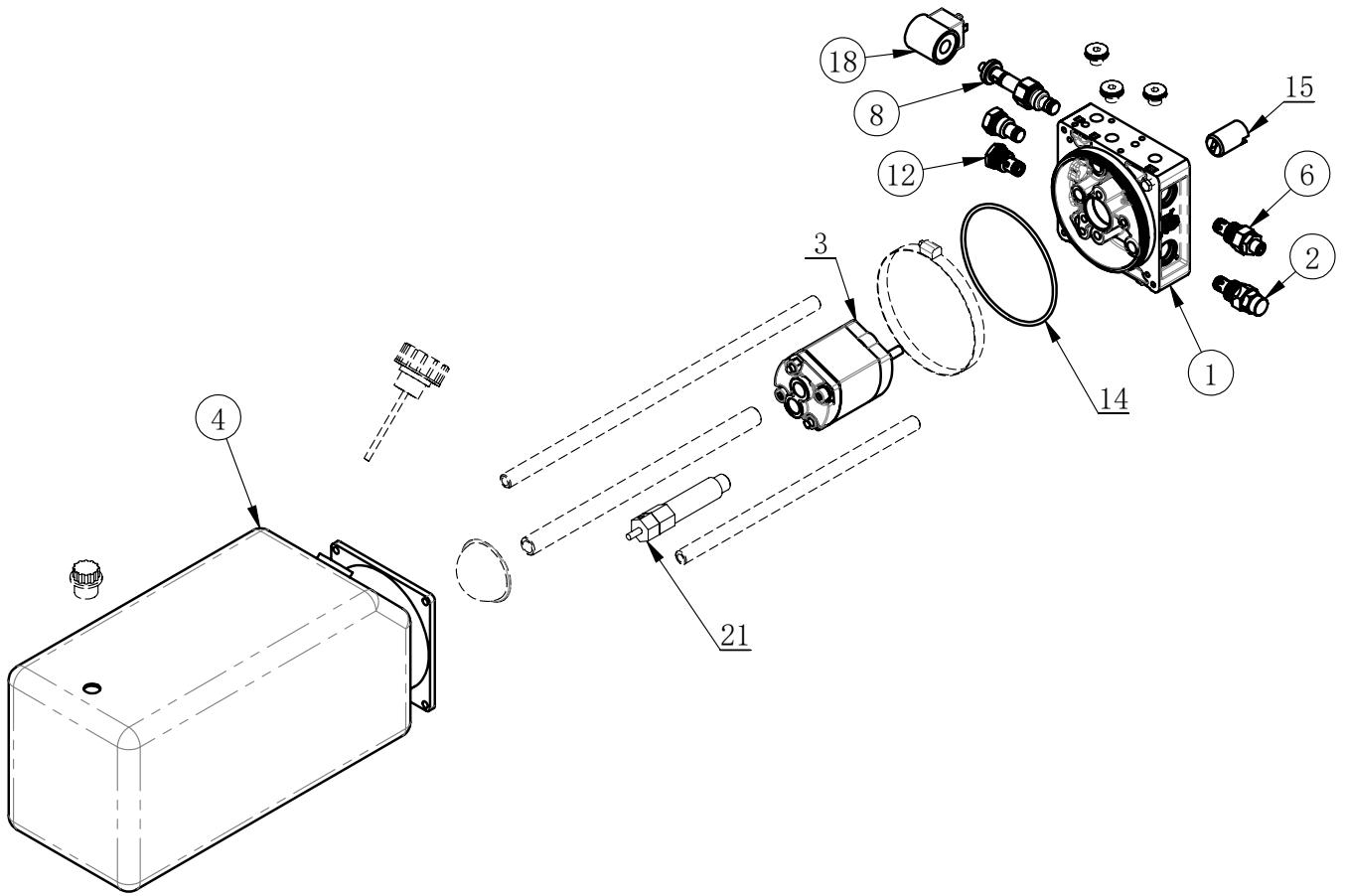

J201-2611000 (400V/3P)			
ITEM	PART. No	DESCRIPTION	QT. Y
1	J601-1921001	Central manifold type one	1
2	J401-1331015	Relief valve	1
3	J401-1331007	Gear pump	1
4	J101-1132A03	SPUARE FUEL TANK	1
6	J401-1331016	Adjustable flow valve	1
8	J401-1331002	Solenoid 2/2 way valve 3/4-16 UNF	1
12	TC-20-1031206	check valve ball type	1
14	UF2057	O Seal ring $\phi 117*3.55$	1
15	J101-1130101	Relief valve dumpener	1
18	J401-1331003	Coil 24V AC	1

J101-1181000 (230V/50Hz/1P)			
3	J401-1331007-220	Gear pump	1
21	J401-1331018	Starting valve Lengthen	1

J101-1181000 (230V/60Hz/1P)			
3	J401-1331007-220	Gear pump	1
21	J401-1331018	Starting valve Lengthen	1

J233-1800000

Revision A-01

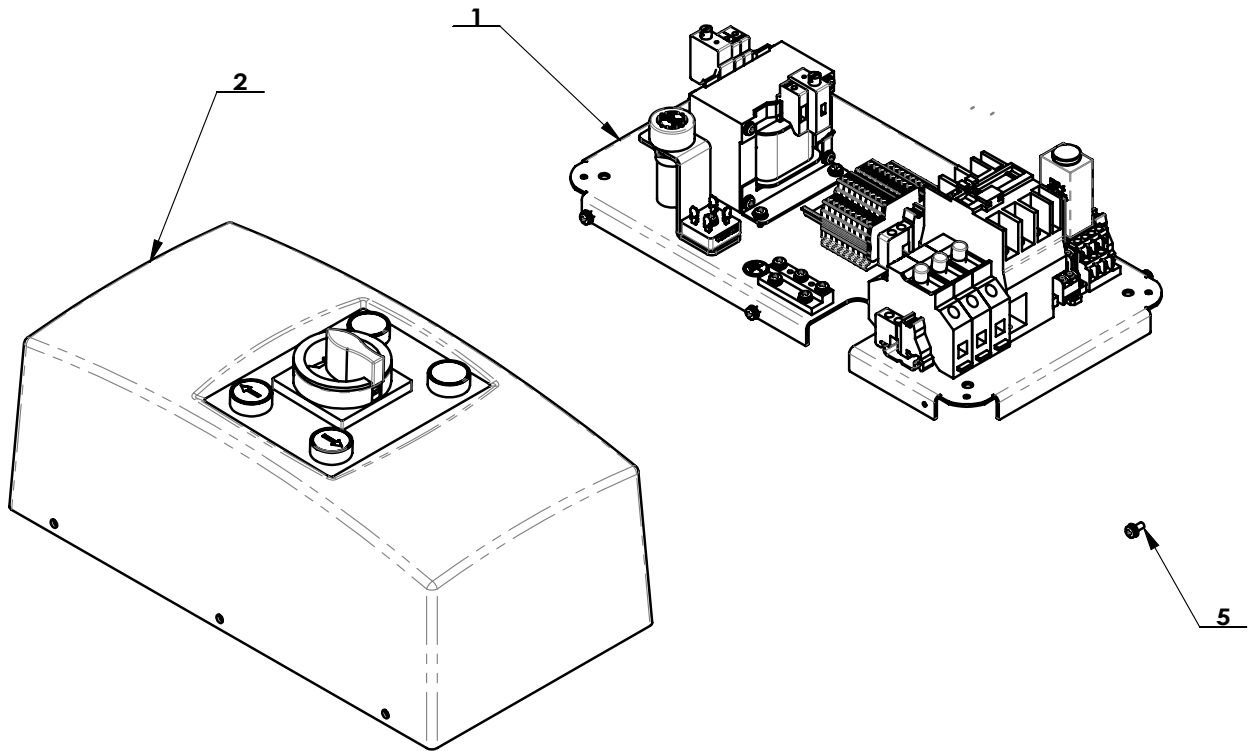

J233-1800000 (400V/3P)			
ITEM	PART. No	DESCRIPTION	QT. Y
1	J233-1810000	ELECTRICAL CONTROL PANEL	1
2	J233-1820000	ELECTRICAL CONTROL BOX AND COVER ASSEMBLY	1
5	GB9074.4-M4x10	Cross recessed pan head flat spring washer combination screw	6

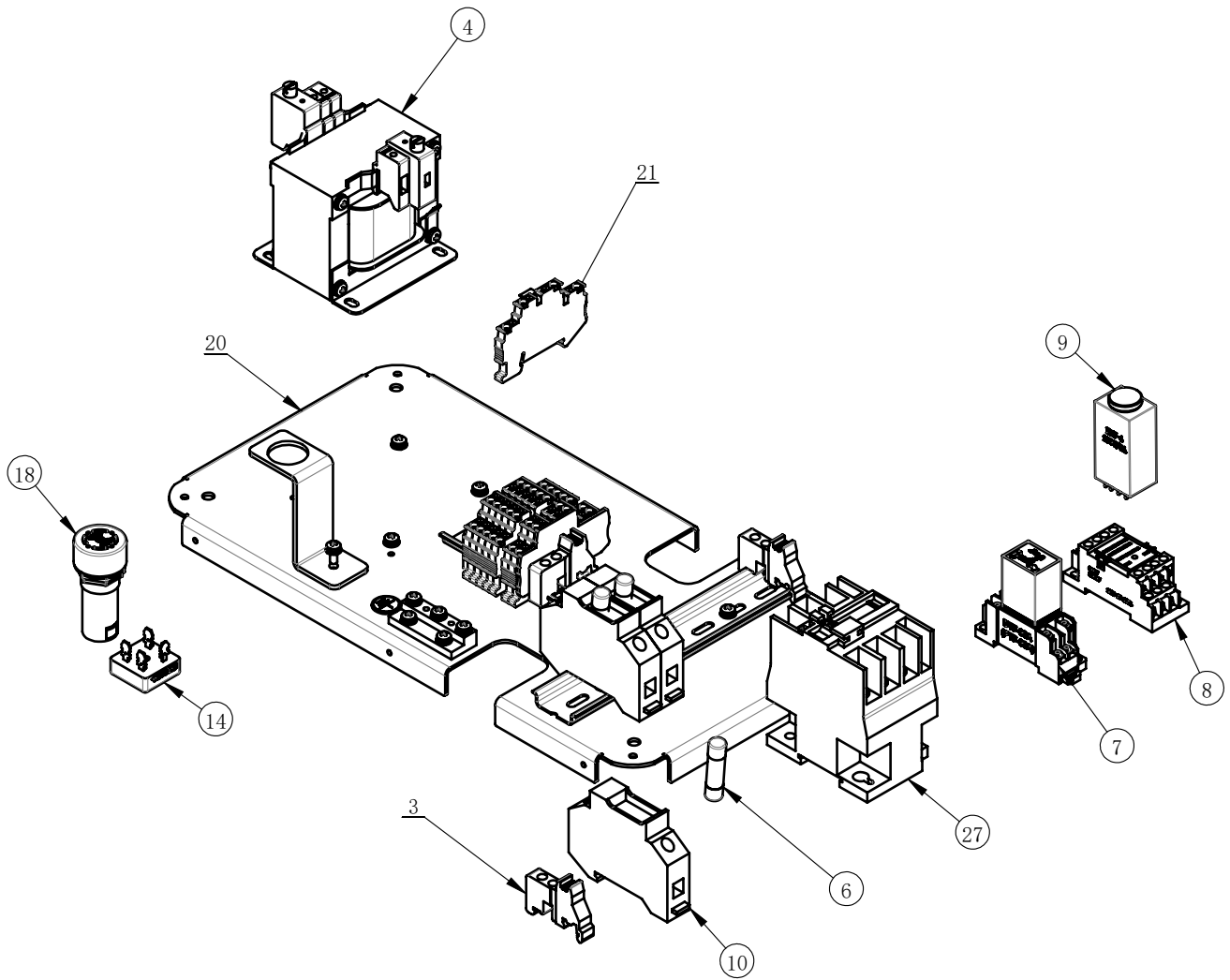

J233-1810000 (400V/3P)			
ITEM	PART. No	DESCRIPTION	QT. Y
3	TC-E-5130000	Connector	4
4	TC-E-3840232	Transformer	1
6	TC-E-7101512	Fuse	3
7	TC-E-4400224	Intermediate relay	1
8	TC-E-43Z6524	Socket	1
9	TC-E-43Z6424	Time delay	1
10	TC-E-7128323	Fuse Holder	3
14	TC-E-7103510	Rectifier Bridge	1
18	TC-E-7202408	Buzzer	1
20	J101-1121001	Electro Plate	1
21	TC-E-511TB25	Connector	8
27	TC-E-4221024	AC Contactor	1

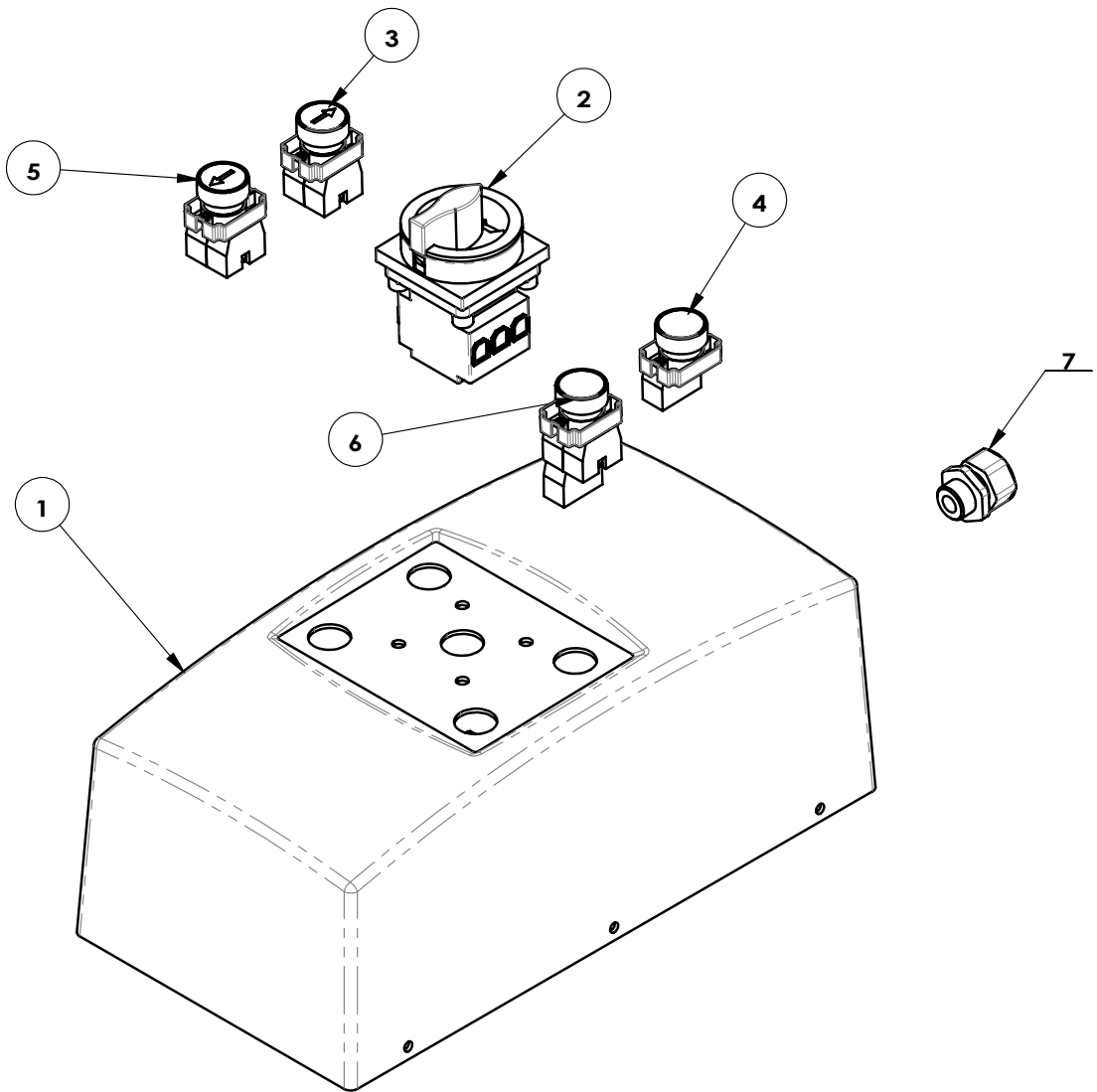

J233-1820000 (400V/3P)			
ITEM	PART. No	DESCRIPTION	QT. Y
1	J101-1122018	Plastic cover	1
2	TC-E-2401616	Main Switch	1
3	J101-1122M00	Push Button	1
4	TC-E-270BA31	Push Button	1
5	TC-E-2702343	Push Button	1
6	TC-E-270BA53	Push Button	1
7	TC-E-7700020	CABLE LOCK HEAD M20X1.5	1