



**STENHØJ** AUSTRALIA

PRODUCT INFO 27<sup>th</sup> of December 2017



**NEW MOLNAR Mobile columns**

**SM 75S**



**Stenhøj Pty Ltd**  
ABN 86 611 678 196

2/95 Darley Street  
Mona Vale 2103  
NSW Australia

0450 950 234  
rko@stenhoj.com.au  
[www.stenhoj.com.au](http://www.stenhoj.com.au)

Lifting the Level



- Motor protection on each column
- Main switch stop on each column

## 11. DIMENSION SKETCH

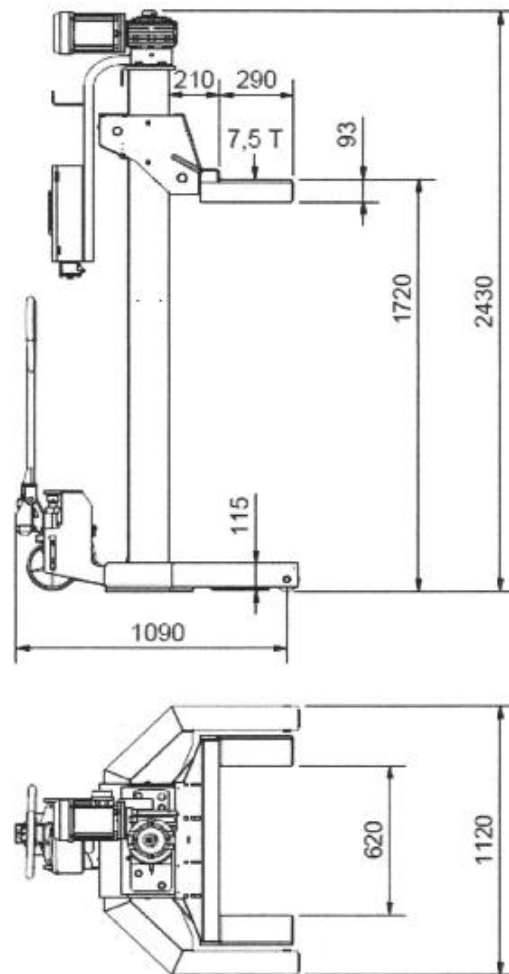

5

### Capacity

**7500 kg/Column**

- Electro mechanical
- Up to 8 Columns
- Lifting and lowering speed 0,63 m/min
- Electric motor 3 kW, 400 V 3 phase, 50 Hz
- Fixed forks for wheel sizes 800-1130mm
- Wheel adaptors for smaller wheels available
- Control voltage 24 V DC
- Motor protection IP54
- Noise level less than 70 db(A)

**Safety features:**

- Automatic synchronization during the whole lifting and lowering
- Safety supervision of synchronization and all operating functions
- Safety against locking of load pick-up carriage
- Control lamps for "operation mode", "ready", "synchronization"
- Control lamps for "Single", "Group" and "Auto" operation
- Lockable main switch



**AVAILABLE IN ADELAIDE WAREHOUSE APRIL 2018  
(Made in Denmark)**