

Mobile 7,5T–Cable version.

T62392

User Manual

(ORIGINAL VERSION)

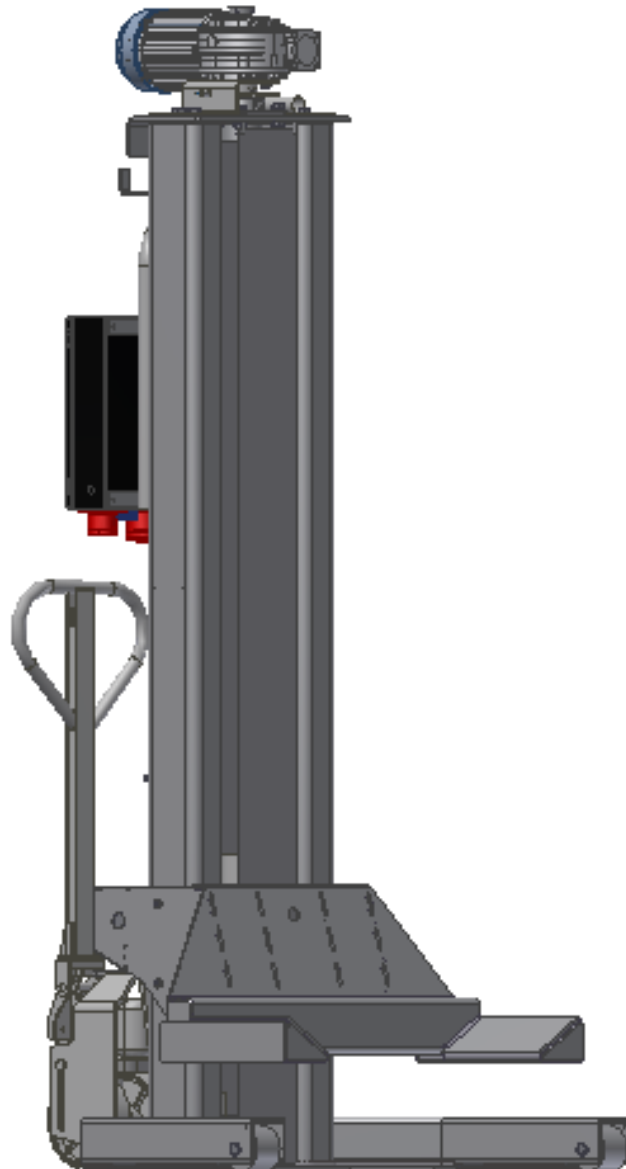

TABLE OF CONTENTS

Table of contents	2
General	3
Technical specifications	4
Dimension sketch.....	5
Commissioning	6
Electrical specifications.....	7
Short operation instructions	9
Detailed operation instructions.....	10
Maintenance	14
Error codes/ Trouble shooting	15
Synchronization	16
Emergency lowering from a nut break.....	17
Check list	18

GENERAL INFORMATION

The Somers lifts are a result of many years of experience. The high quality requirements and the superior design guarantee lifts with a very high reliability and long life. To avoid unnecessary damages and dangers and to secure a correct installation, an operation free of problems and observance of the functional safety of the lift, it is very important to observe the prescriptions in this manual very carefully.

The conditions of a safe, correct and reliable use of the lift is the knowledge of the fundamental safety rules and prescriptions.

Installation and test of lift:

Security relevant work on the lift and safety checks of the lift are only allowed carried out by persons trained in this these matters. They are generally and especially in this manual referred to as skilled persons or technicians.

Skilled persons/technicians are persons who either through their education and experience are able to approve the lifts and are experts in decisive safety rules and prescription, or through participation in courses and training at the manufacturer's possess a thorough knowledge and experience with the lifts.

WARRANTY

This lift is guaranteed for one year, covering faults due to manufacturing or material defects, provided that the installation, operation and maintenance instructions are observed. The warranty implies that during the warranty period Somers is committed either to repair or to replace – after own decision - defective spare parts fitted in the Somers lift. No other warranty claim can be put in under warranty.

IMPORTANT: Spare parts used in the Somers lifts are quality tested and type approved by the Danish safety authority (Teknologisk Institut), and comply with the criteria laid down in DS/EN 1493:2010. Please note that the use of safety spare parts or other essential components which do not fulfill these criteria may result in the type approval becoming void and the lift will thereby no longer keep the safety regulations defined by Somers together with the relevant authorities.

Somers's product/deficiency liability and warranty cannot be claimed if concrete damages or failures are a result of the use of spare parts not originating from Somers.

TECHNICAL SPECIFICATIONS OF THE LIFT

Description: Mobile electro-mechanical columns for lifting under wheels.

Type:	4-columns	6-columns	8-columns
Number of columns:	4	6	8
Lifting capacity:	4 x 7500 kg = 30.000 kg	6 x 7500 kg = 45.000 kg	8 x 7500 kg = 60.000

The lift is designed for working underneath the load pick-up carriage.

Standing on the lifting carriage is not allowed.

Transport of persons on the lift is not allowed.

2. ADDITIONAL GENERAL INFORMATION

Admissible static lateral pressure: 1000 N

Admissible dynamic pressure on the windward side
of the lifted vehicle: 100 N/m²

3. CONTROL UNIT

Integrated in the columns, with synchronization and safety supervision.

4. LIFTING AND LOWERING SPEED

Approx. 0,63 m/min

5. ELECTRO-MECHANICAL DRIVE

Electric motor: 3 kW, 400 V, 3 phases, 50 Hz, 1.400 rpm.

6. PICK-UP PADS

Fixed forks for wheel sizes Ø800-1140mm, fork length 300 mm.

Wheel adaptors can be fitted for smaller wheels.

7. ELECTRICAL EQUIPEMENT

Operating voltage: 3 x 400 V, PE, 50 Hz, sense of direction clockwise

Control voltage: 24 V DC

Motor protection: IP54

Range of temperature: -10° to +50° C

IMPORTANT: Lift must not be used in explosion areas.

8. NOISE LEVEL

Measured at the working area of the operator: less than 70 db(A).

9. SAFETY EQUIPMENT

- Electrical:
- Automatic synchronization during the whole lifting and lowering movement with a difference between columns of max. 50 mm.
 - Safety supervision of synchronization and all operating functions
 - Safety against locking of load pick-up carriage
 - Control lamps for "operation mode", "ready" and "synchronization"
 - Control lamps for "Single", "Group" and "Auto" operation
 - Lockable main switch

- Motor protection on each column
- Main switch stop on each column

11. DIMENSION SKETCH

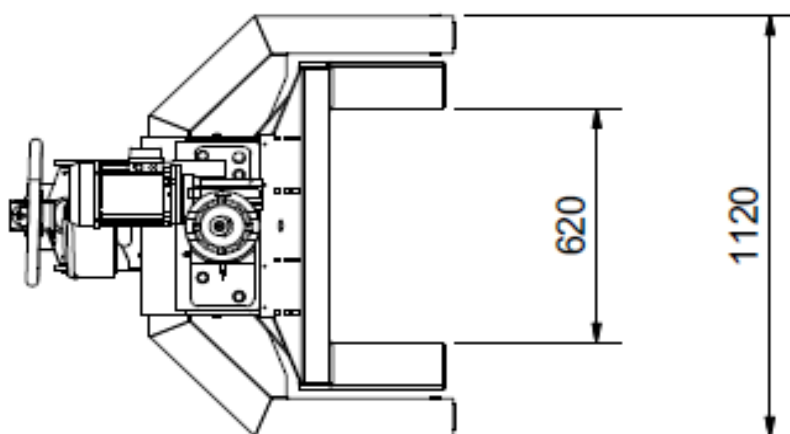
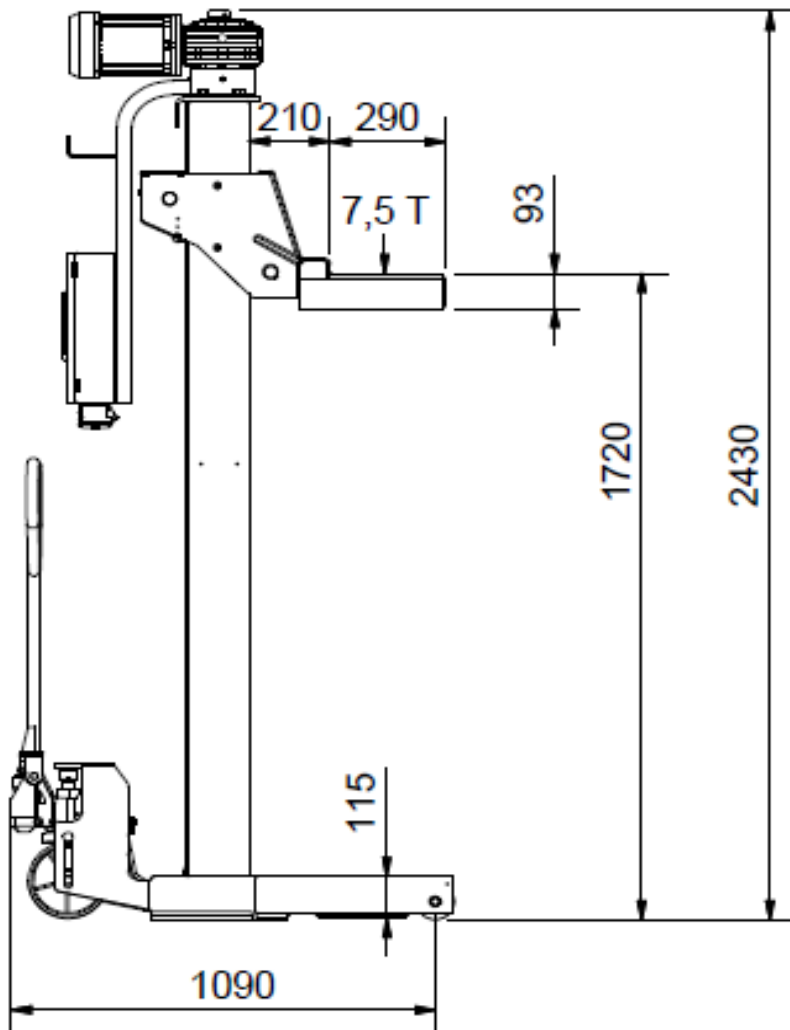

COMMISSIONING

COLUMN

- 1 Transport: columns are shipped in the vertical position. Do not tilt them!
2. Unloading from truck:
 - Lift column package with 2 columns using a fork truck under the upper transport bracket.
 - It is also possible to lift at the front top plates of columns by means of chains. Only lift one column at a time.
 - Lift and lower carefully. Before lifting check that cross beams and unions are not damaged or loose.
3. Remove packing material.
4. Remove the transport brackets.
5. Take care that column when loaded lowers completely to the floor.

POSITIONING

1. Place columns on a smooth and even floor, floor quality at least as B20 concrete.
2. Max. permissible floor slope: 1°
3. Sufficient distance from lift to walls must be kept in order to secure statutory escape route.

ELECTRICAL SUPPLY

NOTE:

- The lift is as standard wired and adjusted to operate at 400 V operation voltage.
- Wiring has to comply with all local electrical codes. Local safety rules have to be kept.
- Incorrect wiring can be fatal.
- Incorrect operation voltage or electrical supply can cause internal irreparable electrical damage in the columns.

ELECTRICAL SPECIFICATIONS:

Electrical connection: 400 V, 3 phases + earth, 50 Hz.,
Motor: 4 columns: 4 x 3 KW
6 columns: 6 x 3 KW
8 columns: 8 x 3 KW
Fuses: 3 x T 16 A according to VDE 0100.
Min. core diameter: 2,5 mm²
Direction of rotation is clockwise.
Phases: L1 (brown), L2 (black)
L3 (Grey), Neutral = Blue
Earth (yellow-green)

NOTE:

- Do not open control boxes before power supply has been disconnected.
- Any modification in the electrical connection must only be carried out by an authorized electrician.
- The electrical control unit and the wiring of the lift must not modified.

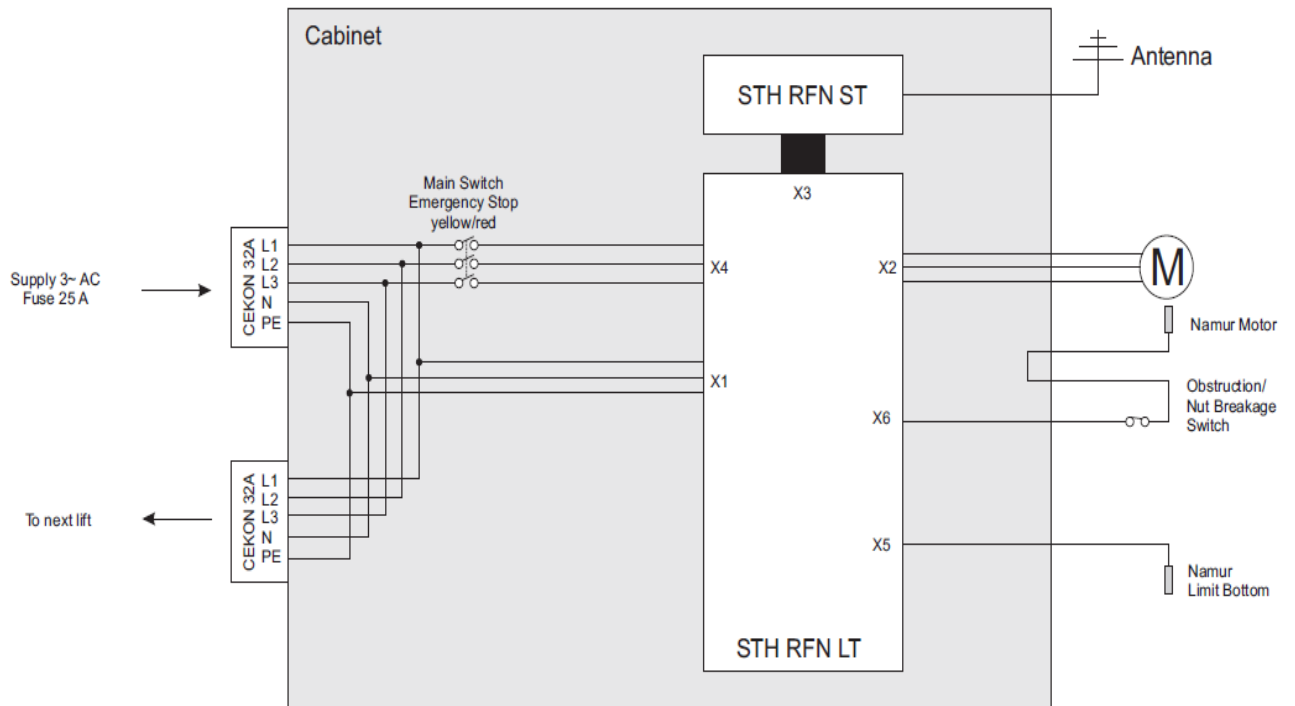

IMPORTANT:

Before operating the lift the "detailed operation instructions" has to be read carefully and followed. Should the contents of these instructions not be followed, thus causing damages to lift or persons Somers will not be held responsible for these damages.

1. Interconnect the columns in a circle around the vehicle (se picture 3). Lock the plugs in the sockets. Plug main power cord to the appropriate power supply.
2. Check all functions on an unloaded lift by following the detailed operation instructions.
3. If no problem is observed according to step 2 the lift is ready to be used.

POSITIONING OF COLUMNS

**The picture showing a complete set with 8 Columns.
Attention! Never use more than 4 Columns on 1 power supply!**

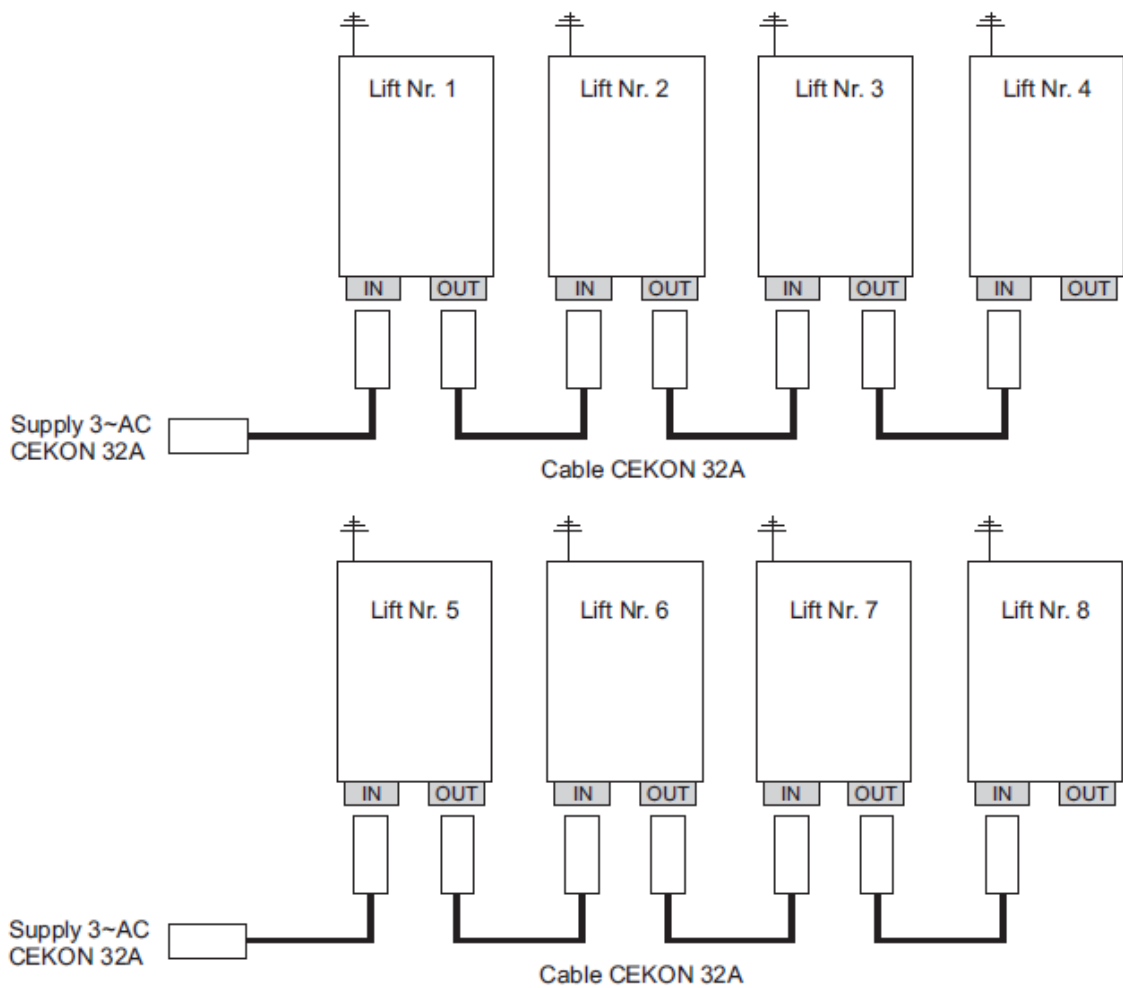

SHORT OPERATION INSTRUCTIONS

INSTALLATION

- Lift must be installed vertically on a level and sufficiently load-bearing floor.
- Place columns next to the wheels of the vehicle, exactly at the centerline of the wheels and position them as far as possible under the wheels, always 2 columns at one common axle.
- When positioning the columns at the vehicle provide sufficient distance between columns and vehicle body; mind protruding wheel hubs.
- The wheel forks can be used for wheel sizes Ø800-1140 mm.
- Lift must only be operated by persons who are 18 years of age and who have been instructed in the handling of the lift. Untrained persons are not allowed to stay in the working area of the lift.
- Never overload the max. Lifting capacity, see name plate of lift.
- Lift vehicle slightly and check immediately that the vehicle is safely placed on the pick-up carriages.
- Inclined and one-sided lifting or lowering of the vehicle is not allowed.

- Operator must keep away from the working area of lift and keep sufficient distance to the moving parts of lift.
- Operator must take care that working area of lift is free of any obstruction and that no person is staying in this area. Clearance to ceiling must be sufficient to lift the vehicle.
- Operator must constantly keep an eye on the lift and its load and immediately stop the lift in case of irregular function.
- Stay on vehicle of pick-up carriage and use of lift as individual lifting tabel is not allowed.
- After finishing raising or lowering main switch must be turned off on all columns and lift must be secured against unauthorized use.
- Follow carefully the detailed operation and maintenance instructions.

DETAILED OPERATION INSTRUCTIONS:

COMMISSIONING / SET-UP

RANGE OF APPLICATION

- The mobile lift is designed to lift commercial vehicle under the wheels.
- Do not exceed max. Admissible lifting capacity, see name plate.
- **IMPORTANT:** Do not install the lift in explosive areas. As standard the lift is not manufactured in an explosion-proof version.

INSTALLATION

- The set-up instructions must be followed carefully, see page 7.
 - Lift must be installed vertically on a level and sufficiently load-bearing floor.
- The positioning of the columns is optional. It is possible to connect 8 Columns together.

Attention! Never use more than 4 Columns on 1 power supply!

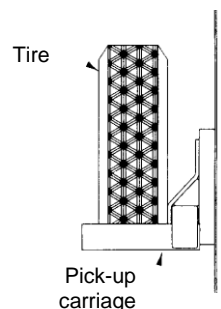

- Place columns next to the wheels of the vehicle, exactly at the centerline of the wheels and position them as far as possible under the wheels, always 2 columns at one common axle.
- When lifting vehicles with double axles please see instructions indicated.
- Place the columns as far under the wheels of the vehicle as possible.
- The wheel forks are designed for wheel sizes Ø800-1140 mm. Extra wheel adaptors are to use if the wheels are smaller.
Note ! Wheel adaptors when used must be placed in pairs on the columns – see below sketch.

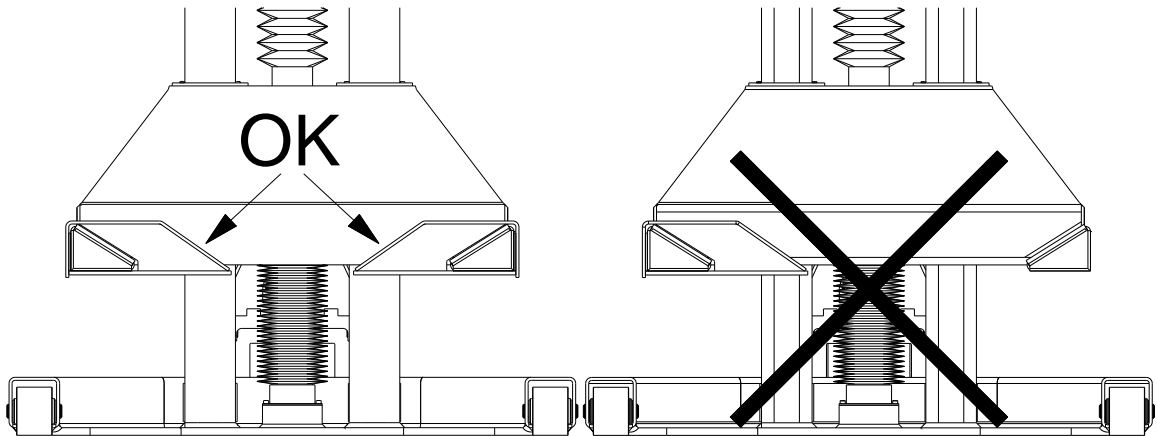

- When positioning the columns at the vehicle provide sufficient distance between columns and vehicle body; take care not to damage protruding wheel hubs.
- Plug all columns with the cables in a circle around the vehicle. Lock the plugs in the sockets.
- Connect main plug to the proper power supply; check that the lift raises when pushing the UP-button.

REQUESTS TO OPERATOR

- Lift must only be operated by persons who are 18 years of age and who have been instructed in the handling of the lift. Untrained persons are not allowed to stay in the working area of the lift.
- Unauthorized transport of persons on the lift is not allowed.
- Unauthorized persons are not allowed to stay in the working zone of the lift.

OPERATION

- Connect one of the columns to the power supply with the power cable.
- Connect all columns together with the power cables.
- Turn on the main power switch on all the columns.
- Wait for 10 sec. The Control units will make a function test.
- Make sure that all columns are set on the same channel, by using the channel button.
- Press the mode button and select Auto on all the columns.
- Press the button "1/0" and the red LED left of the 0/1" button will now constantly shine. The columns are now connected and can now be operated together by using the UP and DOWN buttons

If you desire to only operate one or two of the columns, press the mode button and choose single or Group.
 When you want all the columns to work connected again choose Auto.
 To level the columns again press down, till all lifts are at ground level.

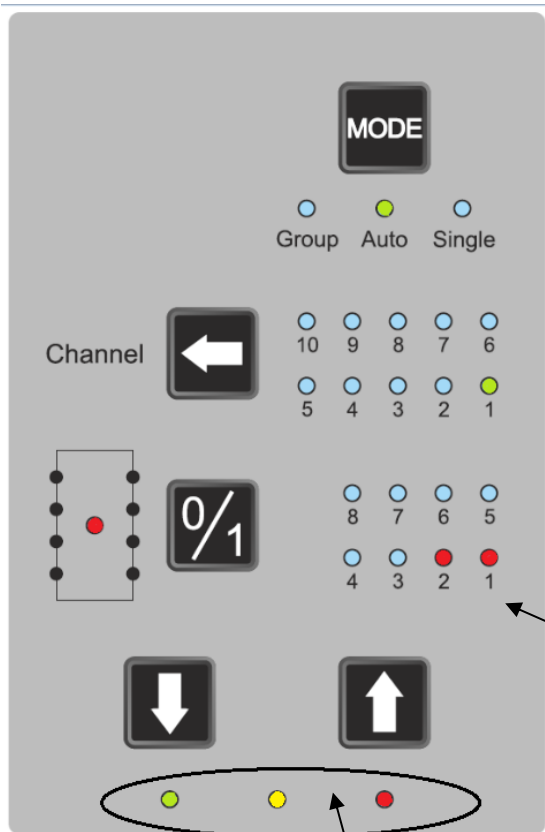

If the operation guide does not work, the columns must be synchronized singlehanded.

Press both the UP and DOWN button. 10 sec.

The yellow and green LED will flash, when the columns are ready to be synchronized.

Lower the lift to the lowest position, and when only the green LED shines the column is synchronized.

Connected and ready to use

Number of columns that is connected

Status indicator/ Error Codes

LIFTING CARRIAGE

- It is not allowed to lift with defective wheels or wheels with insufficient pressure.
- When lifting vehicles with bogie axles follow carefully the instructions from the vehicle manufacturer.
- Lift vehicle slightly until wheels are free, approx. 5-10 cm from floor and check that vehicle is safely placed on the pick-up carriage.

TO BE OBSERVED DURING OPERATION

- Inclined and one-side lifting or lowering of vehicles, for instance in single mode is not allowed.

IMPORTANT: at single mode operation the vehicle can get into a very dangerous inclined position.

- In All modes the synchronization controls the speed of each column, so that the movements of the columns always are synchronized, even with different load distribution, thus interrupting very shortly the movements of the columns which are to catch up with the fastest column.
- In All modes, when pushing the up or down button the lift will only stop when all columns have reached the same height level.
- When the lift is running the operator has to keep clear of the working area of the lift and keep sufficient distance to the moving part of the lift.
- When the lift is running the operator has to check that no obstructions and no persons are in the area.
- Before lowering of the lift all obstacles like support stands, working benches, etc... must be removed. Vehicle doors on the vehicle must be closed.
- All tools, wastes, litters, grease and oil must be removed from the working area around the lift.
- Provide sufficient height clearance in the workshop for the lift and the vehicle.
- The operator must carefully watch the lift and its load and in case of irregular function immediately stop the lift and carry out the trouble shooting, see chapter "trouble shooting".
- In case of trouble, drop-out of control lamps and repairs on the lift the main switch has to be switched off and secured against further re-set. Only authorized persons is allowed to repair the trouble.
- It is not allowed to climb onto the lift or stay in/on the vehicle or the pick-up carriage during operation, neither is it allowed to use the lift as lifting table.
- During work on the lifted vehicle all forces which could make the lift slide, rock or tilt are prohibited.
- When using the lift outside under very windy circumstances the vehicle has to be lowered immediately to bottom position.
- When lifting the vehicle it has to be checked that no leakage in the pneumatic springing or the tires risks to put make the vehicle tilt slightly and thereby lean onto the columns and get damaged.
- After ended raising and lowering the main switch on all columns must be switched off and the lift has to be secured against unauthorized use of the lift.

FURTHER SECURITY INSTRUCTIONS:

- Local safety prescriptions must always be observed.
- Check lift every day. Lift must not be used in case of malfunction or in case of broken or damaged parts.
- Always use original spare parts for repairs.
- It is not allowed to block the operation elements such as up or down buttons or to sidestep their function.

- It is not allowed to change the manufacturer's adjustments of the electrical system.
- Unauthorized persons are not allowed to open the electric control panels; authorized electricians are only allowed to open them when they are disconnected from current.
- Only authorized electricians are allowed to work on the electrical parts.

WARNING: unskilled work can be dangerous and fatal.

- Always keep the working area clean, disorder around the lift may cause accidents.
- Always be alert. Always supervise the work at the lift. Always be sensible. Never use the lift when unconcentrated.
- Be careful not to bump one's head on the vehicle or the lift when working under the lift.
- Be careful when using the extra equipment ! Only use accessories and equipment which have been recommended or prescribed by the lift manufacturer. The use of other equipment may cause personal injuries.

PREVENTION OF POSSIBLE ERRORS:

- The lift must be maintained with care. It has always to be kept clean to secure a long and safe operation. Always observe the maintenance instructions. Check regularly plugs, sockets, connecting cable and power supply cables and have them replaced by an authorized technician in case they are damaged.
- Always keep the electric control panels closed.
- All electrical parts, especially the plug connections and switches, should be protected against moist and dirt.
- Connecting cable and power cable should be rolled up to a min. diameter of approx. 50 cm.
- Do not buckle the connecting cables and power cable, and do not cover them with sharp objects; do not drive vehicle over the cables. Protect cables against warmth and sharp edges. Take care that cables do not get squeezed under the base plates of the columns.
- Do not pull on the connecting cables.
- Do not clean the lift with high pressure or steam.
- It is not allowed to weld or use a blow pipe on the lift.
- Do not use caustic materials on the lift.

MAINTENANCE:

To secure a perfect and long operation of the mobile lift it has to be maintained regularly. The regular check and maintenance of the lift must be carried out in accordance with the valid local rules.

Every month

1. Functional check of all operative elements, check all control lamps.
2. Check of all electric cables and plugs.

Every 3 months

1. Grease with molybdendisulfid (Mo₂S) grease (or equivalent), see below sketch.

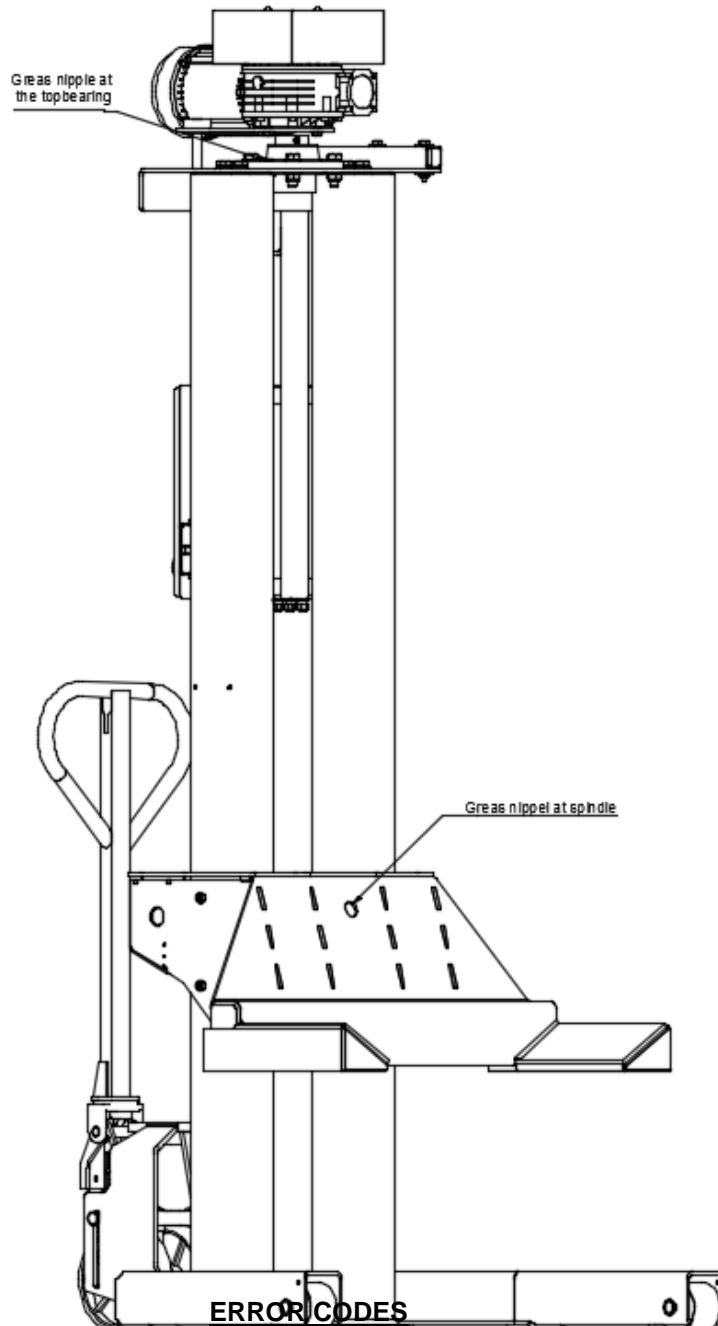

Display	Diagnosis	To do
All LED's is turned off.	Power is missing.	Check if power supply is turned on.

		<p>Check that Power cables are correctly connected.</p> <p>Check that power switch is turned on all control units.</p>
Red Led blinking	Bottom sensor activated.	<p>Check sensor.</p> <p>Contact service if above doesn't solve the issue.</p>
Yellow Led blinking.	<p>The Columns are not referenced.</p> <p>Difference in height between the columns is too large.</p>	The Columns need to be synchronized.
Columns stop when lowering, and yellow LED is blinking.	<p>The Column has run past the bottom stop.</p> <p>-----</p> <p>Parameter for the bottom stop must be changed.</p>	<p>Drive column up until yellow LED turns of.</p> <p>-----</p> <p>Contact service.</p>
Columns stop when driving up, and yellow LED is blinking.	<p>The load on the columns is too high.</p> <p>-----</p> <p>The Columns need to be lubrication.</p> <p>-----</p> <p>Power Supply network is too weak.</p> <p>-----</p> <p>Top stop parameters must be changed.</p>	<p>The columns need to be lowered.</p> <p>-----</p> <p>Lubricate according to the maintain description.</p> <p>-----</p> <p>The Power supply network has to be checked.</p> <p>-----</p> <p>Contact service.</p>
Red LED is on constantly.	Hardware failure.	<p>Disconnect the power supply cables for at least 10s.</p> <p>If problem continues, contact service.</p>
Column stop driving, and green LED is blinking while the up or down button is pushed.	Failure in Power supply network.	The Power supply network has to be checked.
All 3 status LED is on.	Error occurred	<p>The Power supply network has to be checked.</p> <p>If problem continues, contact service.</p>

Synchronization

IMPORTANT:

Under synchronization, the pulse sensor is not activated. The following function is turned off.

- No overload function.
- No detection of obstruction and nutbreak.
- No detection of motor failure.
- No detection of high different between the columns.
- No top stop.

During synchronization with load!

Continuously observe all the columns, to avoid all kind of hazzards.

PROCEDURE:

Press both the UP and DOWN button for 10 seconds.

The yellow and green LED will flash, when the columns are ready to be synchronized.

Lower the lift to the lowest position, and when only the green LED is on the column is synchronized.

The Column is now ready for use. All Columns has to be synchronized individually.

Emergency lowering from a nut break

This procedure, most only be done by a authorized person.

Remove the back cover on the Column with the nut break.



Deactivate the Obstruction/Nut break switch. (Remove it from the obstruction bracket)

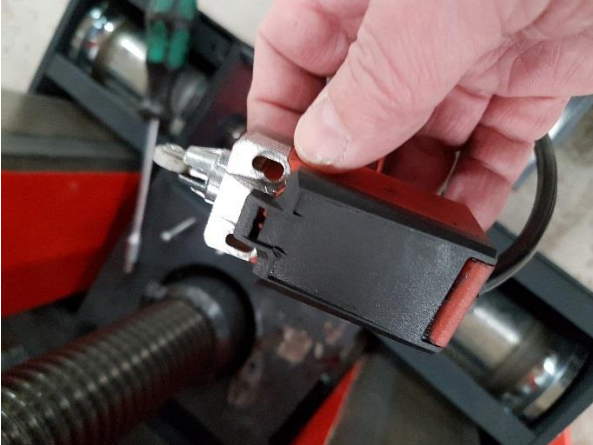

Afterwards this should be done.

Make a restart on the column with the nut break as described under here.

- 1) Connect power supply, and start up the control unit.
- 2) Hold down the "up and down buttons"
- 3) Close down main power supply while the "up and down" buttons is still pressed.
- 4) Connect the power supply again, and when the control unit do the function test (Light show), the "up and down buttons can be released again.
- 5) The column has now been restarted, and the control unit is no longer aware of the nut break error.

Now all columns can be started up, and connected as usual.

Now all columns can move down can the repair can begin.

CHECK LIST:

Must only be carried out by an authorized technician!

TEST POINTS

- Visual control, general condition of the lift
- Column, including:
Column protection, corrosion, deformations, scratches
Spindle and wear on lifting nut
- Carriage, including:
corrosion, deformations, scratches, guiding rollers and bearings
- Wheel jack, including:
Wheel front and rear, wheel jack
- Electrical equipment, including:
Synchronization and supervision, free movement of switches, electric cables and plug connections.
- Test run of the whole lift with nominal load.
- Name plate, all labels, short operation instructions, capacity

