

Betriebsanleitung | Prüfbuch  
Operating manual | Inspection book  
Manuel d'exploitation | Carnet de contrôle

Manuale operativo | registro di controllo

JUMBO LIFT 3200 NT

HYMAX XX 3200 PH

Serien Nr.:  
Serial No.:  
N° de série :  
N° de serie:  
N. di serie:



ist eine Marke der Otto Nußbaum GmbH & Co. KG  
is a brand of Otto Nußbaum GmbH & Co. KG  
est une marque de la société Otto Nußbaum GmbH & Co. KG  
es una marca de Otto Nußbaum GmbH & Co. KG  
è un marchio di Otto Nußbaum GmbH & Co. KG



## 1 Introduction

Nußbaum products are a result of many years of experience. A high quality standard and superior concept guarantees you reliability, long lifetimes and economical operation. To prevent unnecessary damage and hazards, read this operating manual carefully and always comply with its contents.

! **Any other use, or use beyond purpose is considered improper.**

! **Otto Nußbaum GmbH & Co.KG is not liable for any resulting damage. The operating company alone carries the risk.**

### Proper use also includes:

- Adherence to all instructions in this operating manual and
- Compliance with inspection and maintenance work and the inspections stipulated.
- The operating manual is to be followed by all personnel working on the system. This is notably with regards to Section 3 "Safety conditions"
- In addition to safety information from the operating manual, comply with rules and regulations at the location of use.
- Proper system handling

### Operating company obligations:

The operating company is obliged to only permit personnel to work on the system who

- Understand the principle regulations about work safety and accident prevention and who have been trained in working with the system.
- Have read the safety section and warning information in this operating manual, have understood it and confirmed learning with a signature.

### Hazards in working with the system:

Nußbaum products have been designed and built to state-of-the-art and to recognized safety standards. However, improper use may lead to hazards to life and limb of the user or result in property damage.

The system may only be operated

- For proper intended use
- If it is technically in perfect condition

### Organizational measures

- The operating manual is always to be kept ready at the location of use of the system.
- Supplemental to the operating manual, refer to and comply with generally valid legal and other binding regulations for accident prevention and for environmental protection.
- Check occasionally that personnel have an awareness of hazards and safe work in compliance with the operating manual!
- Use personal protective equipment as needed or required by regulations.
- All safety and hazard information on the system is to be kept in a legible condition!
- Replacement parts must meet technical specifications of the manufacturer. This is only guaranteed for original parts.
- Deadlines pre-set or given in the operating manual for repeating tests / inspections must be followed.

### Maintenance work, error removal

- Comply with pre-determined setting, maintenance and inspection work and intervals in the operating manual, including details for exchanging parts / part fittings! These activities may only be done by specialists who have participated in a special factory training.

### **Guarantee and liability**

- In principle, our "General sales and supply conditions" apply.  
Guarantee and liability claims for personal and property damage are excluded if due to one or more of the following causes:
- Improper use of the system.
- Improper assembly, commissioning, operation and maintenance of the system.
- Operating the system with defective safety devices or improperly attached or non-functional safety and protection devices.
- Non-compliance with information in the operating manual in terms of transport, storage, assembly, commissioning, operation, maintenance and fitting of the system.
- Independent construction changes to the system.
- Independent changes to the system (e.g. drive ratios: power, rotation speed, etc.)
- Improperly done repairs.
- Catastrophic cases due to foreign influences or force majeure.

## 2 General information

Technical documentation contains important information for safe operation and for retaining functional safety of the system.

- To verify system set up, the set up protocol form is to be signed and sent to the manufacturer.
- Forms are available in this inspection book for use in verifying single, regular and extraordinary safety checks. Use the forms to document inspections and leave the completed forms in the inspection book.
- The system master forms must record changes to the construction and changes to set up location.

### 2.1 Set up and test the system.

Safety relevant work on the system and safety inspections may only be done by personnel specifically trained to carry it out. They are designated in general and in this documentation as technical experts and specialists.

- Technical experts are people (freelance expert engineers, TÜV specialists) that may inspect and assess due to their education and experience with lift systems. They are knowledgeable in the appropriate work safety and accident prevention regulations.
- Specialists (competent people) are people who have sufficient knowledge and experience with lift systems and have participated in a special factory training by the system manufacturer.

### 2.2 Hazard information

To become aware of the hazardous points and important information, the following three symbols are used with the descriptive meaning. Pay particular attention to text positions that are labeled by these symbols.

 *Note! Labels information about a key function or points to an important remark!*

 **Caution! identifies a warning of possible system damage or other operating company property damage if the highlighted process is not done properly!**

 **Danger! identifies a danger to life and limb, if the highlighted process is not done properly there is a mortal danger!**

### 3 Safety regulations

When working with systems comply with legal accident prevention regulations according to BGG 945, inspection of lifts; BGR 500 and operation of systems; VBG 14.

**Particular attention is drawn to compliance with the following regulations:**

- When operating the system, follow safety regulations and operating instructions in the operating manual.
- The total weight of the accepted load may not exceed 3,200 kg,
- Only personnel aged 18 or over may operate systems independently, they must be trained in system operation and have their work verified by the company. They must be explicitly tasked with operating the system (excerpt from BGR 500), see transfer protocol.
- During lifting or lowering, the work area of the system should be clear of people.
- It is prohibited from moving people with the lift.
- It is prohibited to climb onto the system.
- The lift must be completely lowered before the vehicle is driven on, and it may only be done in the intended direction.
- For vehicles with low floor clearance or custom equipment, check before driving, whether it could be damaged.
- The set up of standard lifts is not permitted in fire and explosion endangered work shops.
- Caution when leaving car engines running in enclosed spaces: danger of poisoning.
- When removing heavy vehicle parts (e.g. motors) the centre of mass of the vehicle changes. In this case secure the vehicle against falling using suitable means.

- Initial access into the lift may only be done after the main switch is off and locked.
- Secure the lift against unauthorized use by switching off the main switch and by using a padlock.
- Always keep the lift and work space clean and dry.

#### 3.1 Safety inspection

The safety inspection is required to guarantee operational safety of the lift system. It is to be done:

1. before first commissioning after setting up the lift system  
use the "single safety inspection" form
2. After first commissioning, check regularly at least once per year.  
Use the "regular safety inspection" form
3. After changes to the lift system construction  
Use the "extraordinary safety inspection" form

**! Single and regular safety inspections must be done by a specialist. It is recommended to do maintenance at the same time.**

**ii** *After a change in construction (for example changing the load carrying capacity or changing the lifting height) and after significant maintenance on load carrying parts (e.g. welding work), inspection by a technical expert is required (extraordinary safety inspection)*

This inspection book contains forms with a detailed inspection plan for safety inspections. Please use the appropriate form, record the condition of the inspected system and leave the completed form in this inspection book.





- Align the lift  
To prevent hollow spaces, correct any unevenness in the floor by putting shims under the base frame (e.g thin metal strips). Use suitable supports to ensure continuous contact between the floor and base frame.

- Tighten safety anchors with torques recommended by the manufacturer.

**!** Each anchor must be tightened to the required torque. Safe operation of the lift is not guaranteed with a lower torque. Follow the instructions of the anchor manufacturer.

- Move the lift upwards and downwards several times, then check the anchors with the torque wrench and tighten if required. Check the hydraulic lines for leak-tightness.
- Balance the lift again if required.
- Mount all hose covers.
- Anchor the foot bumpers included beside the lift on the floor. For this, lower the lift to the lowest position. Position the foot bumpers and permanently anchor them. Distance between the drive in rails and the foot bumpers approx. 20 mm (foot bumpers may not touch the drive in rails).

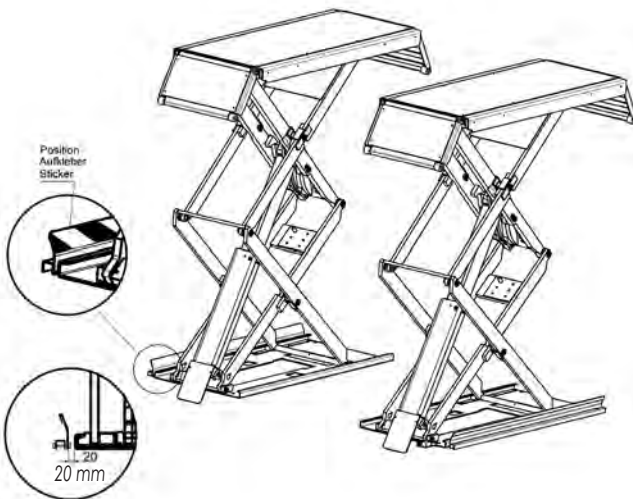

Position of the foot bumpers

016

### 4.3 Fill and vent the hydraulic systems

- The lift is factory pre-installed; meaning the hoses and pipe connections are properly assigned. Finally, check the power connection, check for correct hydraulic oil in the proper volume and leak-tightness of the connection when setting up the lift.  
If the hose connections are still open, e.g. for the purposes of hose extension, then air may be entrapped resulting in start up problems or challenges with smooth running. Check and ensure proper allocation of hose connections.

**!** This procedure must always be completely carried out. This means, first fill and then vent.

#### Correct method of filling and balancing (lift with HyperFlow system):

- Close the emergency discharge screws "N1" (14) and "N2" (15).
- Push the ↑ "Lift" button to move the lift upwards without a load to the maximum height.
- Continue holding the ↑ "Lift" button. This starts the "Overflow procedure". Oil flows from the hydraulic pump through the command and downstream cylinders and back into the tank.
- After releasing the ↑ "Lift" button, the lift lowers a few millimetres and closes the overflow openings.
- The system is now vented and smooth operation can happen.
- The lift now has its normal operating function.

## 4.4 Commissioning

 Before commissioning, a single safety inspection must be done (use the "single safety inspection" form)

If the lift set up is done by a specialist (factory trained assembler) then he can also do the safety inspection. If the set up is done by the operating company then a specialist must be tasked with the safety inspection. The specialist confirms seamless operation of the lift on the set up protocol for single safety inspection and releases the lift for use.

 After commissioning, the set up protocol must be completed and sent to the manufacturer.

## 4.5 Changing the assembly location

To change the assembly location the pre-conditions must be met according to the assembly guidelines. The location change is to be done according to the following sequence.

- Move the lifting stage upwards to approx. 1,000 mm
- Loosen and remove all hose covers.
- Loosen base plate anchors.
- Lower the lift to the lowest position.
- Disconnect power.
- If necessary, disconnect the hydraulic lines on the operating unit only, and seal them off with blind stoppers.
- If necessary, suction off the hydraulic oil.
- Transport the lift with the unit to the new set up location.
- Assemble the lift according to the procedure during assembly and anchoring before first commissioning.



**Use new anchors. The old anchors are no longer fit for purpose!**

 Before re-commissioning, a safety inspection must be done by a specialist (use the regular safety inspection form)

## 4.6 Selecting the anchors

Anchor type	without floor covering (screed/tiles)	with floor covering (screed/tiles)
<b>Heavy duty anchor</b>	BM 10-15/70/40	
Liebig/Strongtie	FH 15/50 B	Anchor length depends on the floor covering
Fischer	HSL-3-G M10/40	
Hilti		
<b>Injection anchor</b>		
MKT	VMZ-A 75 M12-25/145	
Hilti	HIT-HY 200 with HIT-Z M12	
Fischer	Highbond FHB II-A S	
	M12x75/25	

 Similar value anchors and other known brands of anchor manufacturers can be used when considering the conditions.

## 4.7 Assembly

 Follow the instructions enclosed in the anchor packaging.

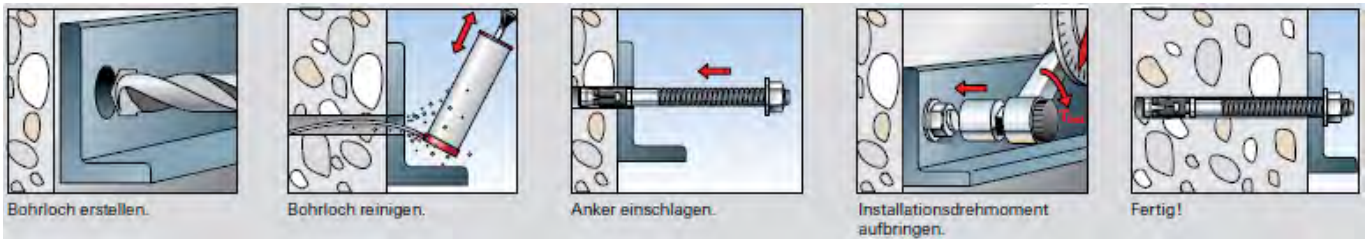

011

## 5 Operating manual



**When handling the system, it must absolutely comply with safety regulations. Carefully read the safety regulations in Section 3 before first operation!**

### 5.1 Operating element

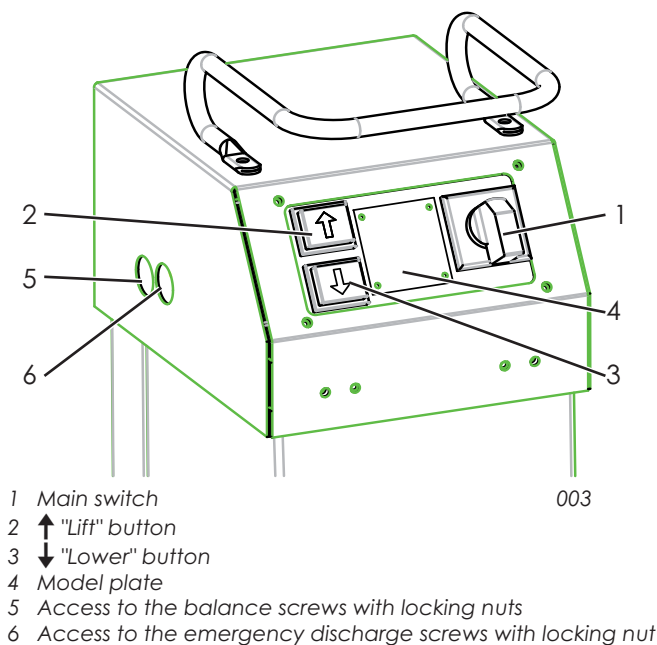

- 1 Main switch
- 2 "Lift" button
- 3 "Lower" button
- 4 Model plate
- 5 Access to the balance screws with locking nuts
- 6 Access to the emergency discharge screws with locking nut

### 5.2 Lifting the vehicle

- Drive the vehicle over the drive rails lengthwise and cross-wise in the centre.
- When driving onto the lift, position the ramps so that the rollers (7) of the ramps (9) are on the ground.

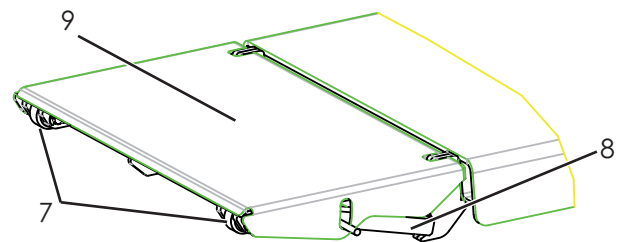

- 004
- 7 Rollers
  - 8 Supports
  - 9 Ramps

Otherwise the supports (8) and ramps (9) can be damaged.

- Secure the vehicle against rolling. Apply the handbrake, put into gear.
- Position polymer overlays below the receiving points approved by the vehicle manufacturer.

 If required, use the ramps for safe acceptance of the vehicle. If the wheel base is too short, fold the ramps underneath.



**To receive the vehicle, the polymer overlays cannot be placed on edge otherwise there is a danger of the car falling.**

- Inspect the hazardous area.  
No person or object may stand in the working area of the lift, or on the lift.
- Switch on controls. Turn the main switch (1) to position "1" (see figure 003).
- Lift the vehicle. Push the ↑ "Lift" (2) button.
- If the wheels are not blocked, interrupt the lifting process and check for proper seating of the polymer overlays.
- Raise the vehicle to the desired working height.  
Push the ↑ "Lift" (2) button.

### 5.3 Lowering the vehicle

- Inspect the hazardous area.  
No person or object may stand in the working area of the lift, or on the lift.

**!** **The vehicles cannot be lowered into the lowest position without wheels. Otherwise the lift cannot raise the load using its own force. The vehicle could be damaged.**

- Lower the vehicle to the desired working height or completely lower it. Push the ↓ "Lower" (3) button (see figure 003).
- The entire lowering process must be observed.
- If the lift is in the detectable lowest position, remove the polymer overlays and drive the vehicle from the lift.

### 5.4 Balance the drive rails

See "Section 4.3 filling and venting the hydraulic system".

## 6 Maintenance and care of the system



**Before maintenance, do all preparation work so there is no danger to life or limb or object damage during maintenance and repair work.**

Value is placed on long lifetimes and safety in the development and production of Nußbaum products. To guarantee the safety of the operator, product reliability, low running costs, keep the warranty and also the long-lifetime of the product, proper set up and operation is just as important as regular maintenance and sufficient care.

Our platforms fulfill or exceed all safety standards of the countries we supply to. For example, European regulations require a service by qualified experts every 12 months of work of the platform. To guarantee the largest possible availability and functional capacity of the lift system, ensure the list of any cleaning, care and maintenance work is done.

The lift system is to be serviced at regular intervals according to the following plan. For intensive operation and higher degree of contamination shorten the service interval.

The complete function of the lift system is to be observed during daily use. Customer service must be informed of any malfunctions or leaks.

To simplify maintenance work, follow instructions on the maintenance sticker that is found somewhere on the unit, depending on the lift design.

### 6.1 System maintenance plan



**Before beginning service, disconnect from power. The system is to be secured against unintentional lowering and unauthorized access.**

#### 6.1.1 As required or visible damage

- Check the polymer overlays and replace if required.

#### 6.1.2 Maintenance 1 x per year

- Check condition of the model plate, load capacity and sticker. Exchange them if damaged or illegible.
- Free the piston rod of the lifting cylinder of sand and dirt.
- Check the wiper for damage.
- Moving parts such as joint bolts and DU bearings, sliding pieces, sliding surfaces and rollers are to be cleaned and checked for wear, exchange if required.
- Lubricate all lubrication nipples with an acid-free multi-purpose grease. Do not over-lubricate.
- All weld seams must have a visual inspection. Stop the system and contact the manufacturer if there are cracks or breaks in weld seams.
- Check the powder coating and improve if required.  
Damage by external influences is to be treated immediately after detection. If these points are not treated, infiltration of deposits of all kinds can cause wide-ranging and permanent damage. These points are to be lightly sanded (120 grit), cleaned and degreased. Afterwards, rework with a suitable touch up paint (note the RAL No.).
- Check the condition and function of the driving ramp.

- Check the condition of the cement floor.
- Check the torque of the fastening anchor. Also see the assembly protocol.
- The condition and function of the load suspension means are to be checked.
- Check the torque of the fastening screws.

#### Torque (Nm) for shaft screws

##### Fastening class 8.8

	0.11*	0.15**	0.20***
M8	20	25	30
M10	40	50	60
M12	69	87	105
M16	170	220	260
M20	340	430	520
M24	590	740	890

##### Fastening class 10.9

	0.11*	0.15**	0.20***
M8	30	37	44
M10	59	73	87
M12	100	125	151
M16	250	315	380
M20	490	615	740
M24	840	1050	1250

- \* Slide friction number 0.10 for very good surface, lubricated
- \*\* Slide friction number, 0.15 for good surfaces, lubricated or dry
- \*\*\* Slide friction number 0.20 surface black or phosphated, dry

- Check electrical components for function. Replace any damaged components.

#### Optional CE stop switch and signalling unit

Push button, main switch

Electrical cable

During assembly and maintenance always check the condition of electrical lines. All cables and lines must be secured so they cannot be crushed, kinked or contact any moving assembly.

- Check hydraulic oil.  
The oil is used if it has a milky colour or if the hydraulic oil smells unpleasantly.

- Check the hydraulic lines and screws for leaks.

Hose lines are to be replaced:

- for damage to the outer coating up to the insert (chafe marks, cuts, cracks)
- for brittleness of the outer coating (crack formation), deformation of the natural shape in the depressurized and in pressurized states.
- if leaking
- for damage or deformation of the mounting fixture
- if the mounting fixture has meandered
- if the lifetime has been exceeded

Repair of the hose line using the implemented hose / mounting fixture is not permitted!

Extending the replacement intervals given in the guideline is possible if the inspection for safe-work condition is done in adjusted, shortened time frames, if required and by competent personnel.

If there is an extension of the replacement interval, no situation may occur which could result in injury of employees or other personnel.

- Check the condition and function of all available safety devices.
- Check the foot bumper for condition and function. Exchange if damaged

### 6.1.3 Maintenance every 2 years

- According to manufacturer details, the hydraulic oil should be changed every two years in normal operations. Various environmental influences e.g. location, temperature swings, intensive operation etc., can have an influence on the quality of the hydraulic oil. For this reason, the oil must be checked during annual safety inspections and maintenance.

The oil is used if it has a milky colour or if the hydraulic oil smells unpleasantly.

To change oil, lower the lift to its lowest position then suction the oil out of the oil container and replace the contents.

The manufacturer recommends a high-quality clean hydraulic oil. The required oil volume and type is to be taken from the technical data. After filling, the hydraulic oil must be between the upper and lower marking on the oil dipstick, or approx. 2 cm below the oil filling opening.

Dispose of the old oil according to regulations to the intended location (district offices, environmental protection office or commercial regulatory office has the obligation to disclose about disposal points).

### 6.1.4 Maintenance every 6 years

- Exchange the protective and hydraulic hoses. Excerpt from BGR 237  
Specifications for the hydraulic hose lines:
  - **Normal specification:**  
6 years including 2 years storage time.
  - **Increased demands** e.g. due to increased usage times, e.g. multi-shift operation, short cycle times and pressure impulses and large external and internal (due to medium) influences which significantly reduce the lifetime of the hose lines: 2 year operation duration

### 6.2 Cleaning and care of the system

A regular and expert clean helps retain the value of the system.

Additionally, it can also be a pre-requisite for the preservation of guarantee claims for any eventual corrosion damage.

The best protection for the system is regular removal of contaminants of any kind.

This includes above all:

- de-icing salt
- sand, pebbles, earth
- industrial dust of all types
- Water, also in connection with other environmental influences
- Aggressive deposits of all types
- Permanent humidity due to insufficient ventilation

**! As a rule: The longer road dust, salt, and other aggressive deposits remain caked onto the system, the more damage they will have.**

The frequency of system cleaning depends, among other things on the frequency of use, of system handling, of workshop cleanliness, and the location of the system.

Furthermore, the degree of contamination depends on the time of year, the weather conditions and workshop ventilation.

Under adverse circumstances, weekly system cleaning might be required, however a monthly cleaning may be sufficient.

- For cleaning, do not use high pressure washers (e.g. steam cleaners)  
Do not use any aggressive and abrasive materials. Instead, use mild cleaners, e.g. a commercially available detergent and lukewarm water.
- Carefully remove all contamination with a sponge, or if required with a brush.

Make sure that there is no residue of the cleaner on the system. These could lead to an increased danger of slipping when moisture is present. So rinse thoroughly with clean water until all residue has been removed.

- Be sure that electric parts of the system, cables, hoses, etc. do not come into contact with water.

- Dry the system with a cloth and spray it with a spray wax or oil.

*ii To encourage/accelerate the airing and/or drying of foundation pits and lift parts, whenever the load receiving fixtures are not in use for a longer period of time, including overnight, lift them out of the foundation pit.*



## 7 Behavior in cases of error

Defective operational readiness of the system may be due to a simple error. Check the system for the listed sources of error.

If the error cannot be removed after an inspection to the named causes, then inform customer service or your dealer.



**Independent repair work on safety devices of the lift and checking the electrical system may only be done by specialists.**

<b>Problem: Motor does not start</b>	
Possible causes:	Remedy:
No power supply	Check the power supply
The main switch (1) is not switched on, or is defective	Check the main switch (1).
Defective fuse	Have fuses checked
The ↑ "Lift" (2) button is defective	Inform customer service
Motor has overheated	Let the water cool. Cooling time depends on the ambient temperature.
Motor defective	Inform customer service

<b>Problem: Motor starts, load is not lifted</b>	
Possible causes:	Remedy:
Load is too heavy	Unload the lift
Hydraulic oil filling level is too low	Refill hydraulic oil
Emergency discharge fixture is not closed	Check emergency discharge fixture
Pressure line leaking	Inform customer service
Hydraulic pump defective	Inform customer service
The coupling between the motor and pump is defective	Inform customer service
Defective cylinder	Inform customer service
Pressure relief valve is defective	Inform customer service

<b>Problem: The lift cannot be lowered</b>	
Possible causes:	Remedy:
Lifting table is sitting on an obstacle	See 7.1 Moving onto an obstacle
Hydraulic valve defective	Inform customer service
The ↑ "Lower" (3) button is defective	Inform customer service

## 7.1 Moving onto an obstacle

If the system moves onto an obstacle during lowering, then it remains in position due to the mechanical resistance. In this case, move the lift upwards by pushing the ↑ "Lift" (2) button on the operating panel until the obstacle can be removed. Afterwards the lift is in a normal work condition and can continue to be operated as described in the operating manual.

## 7.2 Emergency discharge during blackout



**An emergency discharge is an access into the system controls and may only be done by experienced specialists.**

**The emergency discharge must be done in the following described sequence, otherwise it can lead to damage and hazard to life and limb,**



**Any kind of external leakage is not permitted and must immediately taken care of. This is absolutely necessary especially before an emergency discharge.**

Reason which make an emergency discharge necessary are for example, electrical blackout, for errors in the lowering valves, etc.

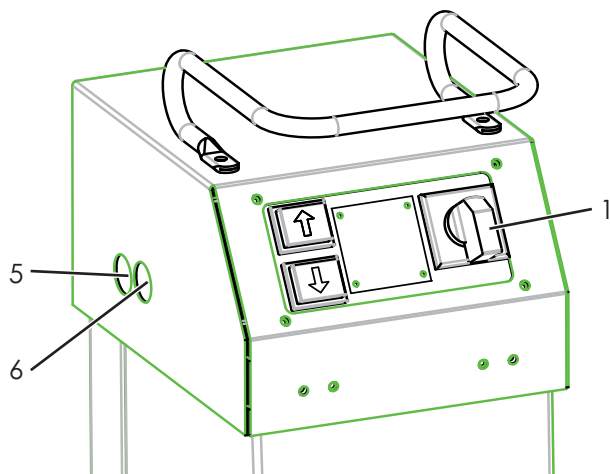

1 Main switch  
5 Access to the balance screws with locking nuts  
6 Access to the emergency discharge screws with locking nut

- Turn off the main switch (1) and secure against unauthorized switch on. Disconnect power.

**! Inspect the hazardous area. No person or object may stand in the working area of the lift, or on the lift.**

- Remove the covers for the emergency discharge screw accesses (6) on both sides.
- Loosen the locking screws (SW17) of the emergency discharge screws "N1" (14) and "N2" (15).

- Initially, using an Allen key (SW5), slowly unscrew the emergency screw N1 by 1/4 turn.

**! Caution: During this process a drive on rail of the lift will lower somewhat (approx. 5 cm). Lowering can be interrupted by closing the emergency discharge screw.**

- Subsequently unscrew the opposite emergency discharge screw slowly a little.

**! The lowering process starts immediately. The speed can be influenced by the degree the emergency discharge screw is opened.**

- Lower the lift to the lowest position.
- The entire lowering process must be continuously observed.
- Afterwards, remove the polymer overlays and drive the vehicle from the lift.
- After finishing the emergency discharge, close and lock the emergency discharge screws N1 and N2 again.
- If required, defective parts must first be replaced before the lift is put into operation again. For this, inform customer service.



**Turn the main switch off and secure against restart. Shutdown the lift until all defective parts have been exchanged.**

**! After exchange of defective parts a "Vent of the hydraulic system" must be done.**

## 8 Technical information

### 8.1 Technical data

Weight	920 kg
System load capacity	3,200 kg
Load distribution	Max. 3:2 or 2:3 in or against the drive- in direction (Consider the centre of mass of the vehicle)
Effective lifting range of the system	Approx. 2,000 mm
System lift time	Approx. 35 s with 3,200 kg load
System lowering time	Approx. 30 s with 3,200 kg load
Operating pressure	Approx. 270 bars
Operating voltage	3 x 400 Volt , 50 Hz
Motor capacity	3 kW
Motor speed	3000 rpm
Oil pump conveying power	3 cm <sup>3</sup>
Pressure relief valve	Approx. 300 bars
Filling volume oil container	Approx. 14 litres
Noise level	≤ 70 dB(A)
on-site connection	3~/N+PE, 400 V, 50 Hz with 16 A fuses, slow, according to VDE regulations

### 8.2 Safety devices

- **Over-pressure valve**  
Hydraulic system fuse against over-pressure.
- **Check valve**  
Secure the vehicle against unauthorized lowering of the load suspension means
- **Two independent cylinder systems (each with a command, follow system)**  
Secure against unauthorized lowering of the lift.
- **Main switch with locking device**  
Fuse to prevent unauthorized use.
- **Dead man controls**  
When the buttons ↑ "Lift" (2) or ↓ "Lower" (3) are released, the corresponding movement stops
- **Foot bumper on the lift (optional)**  
Guard against crushing in the foot area.
- **CE stop (optional)**  
Guard against crushing in the foot area.

## 9 System master sheet

### 9.1 Manufacturer

Otto Nußbaum GmbH & Co.KG  
Korker Straße 24  
D-77694 Kehl-Bodersweier

### 9.2 Purpose

The JUMBO LIFT 3200 NT - HYMAX 3200 PH lift is a lift for cars up to a total weight of 3,200 kg in normal work shop operations and a maximum load distribution of 3:2 or 2:3 in the drive-in direction or against the drive-in direction.

Additionally, there is a distinction between cars operated with front or rear drive.

Set up of the standard lift in explosion endangered workshops or humid work shops (e.g. outside and washing halls) is prohibited. After construction and significant maintenance changes on load carrying parts the lift must be inspected afterwards by a specialist who approves the changes.

Operation of the lift is done by an operating unit that is located immediately next to the lift.

### 9.3 Changes to the design / construction

Inspections by a technical expert are required before recommissioning (date, type of change, technical expert signature).

.....

.....  
*Name, address of technical expert*

.....  
*Location, date*

.....  
*Technical expert signature*

### 9.4 Changing the assembly location

Inspections by a technical expert are required before recommissioning (date, type of change, specialist signature).

.....

.....  
*Name, address of technical expert*

.....  
*Location, date*

.....  
*Technical expert signature*

10 Data sheet

JUMBO LIFT 3200 NT - HYMAX XX 3200 PH

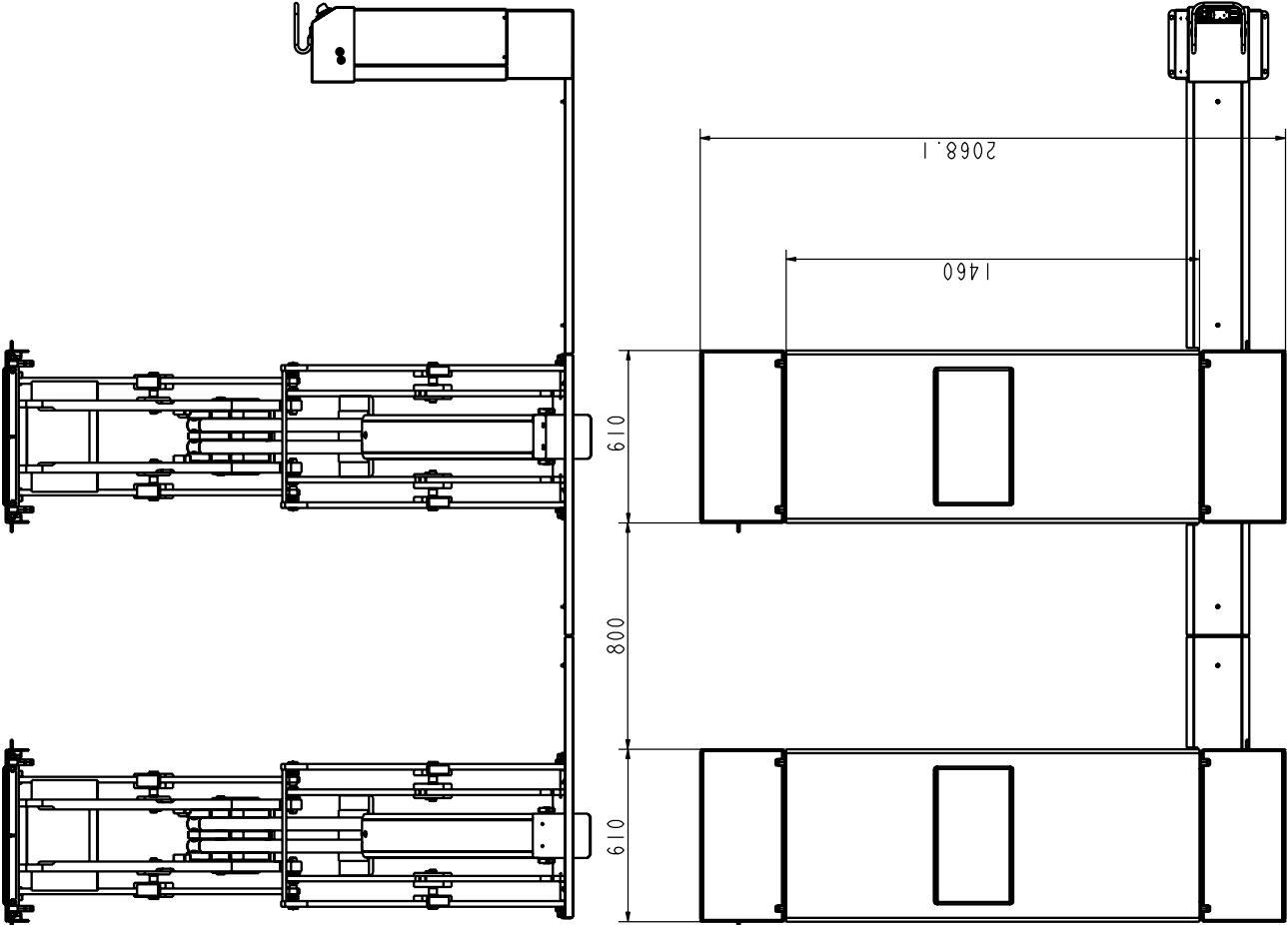
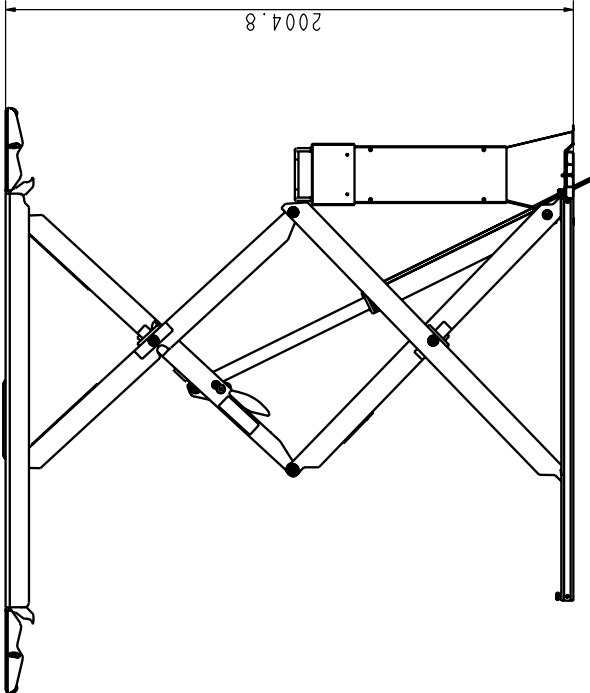

# 11 Foundation plans

## 11.1 Sub-floor

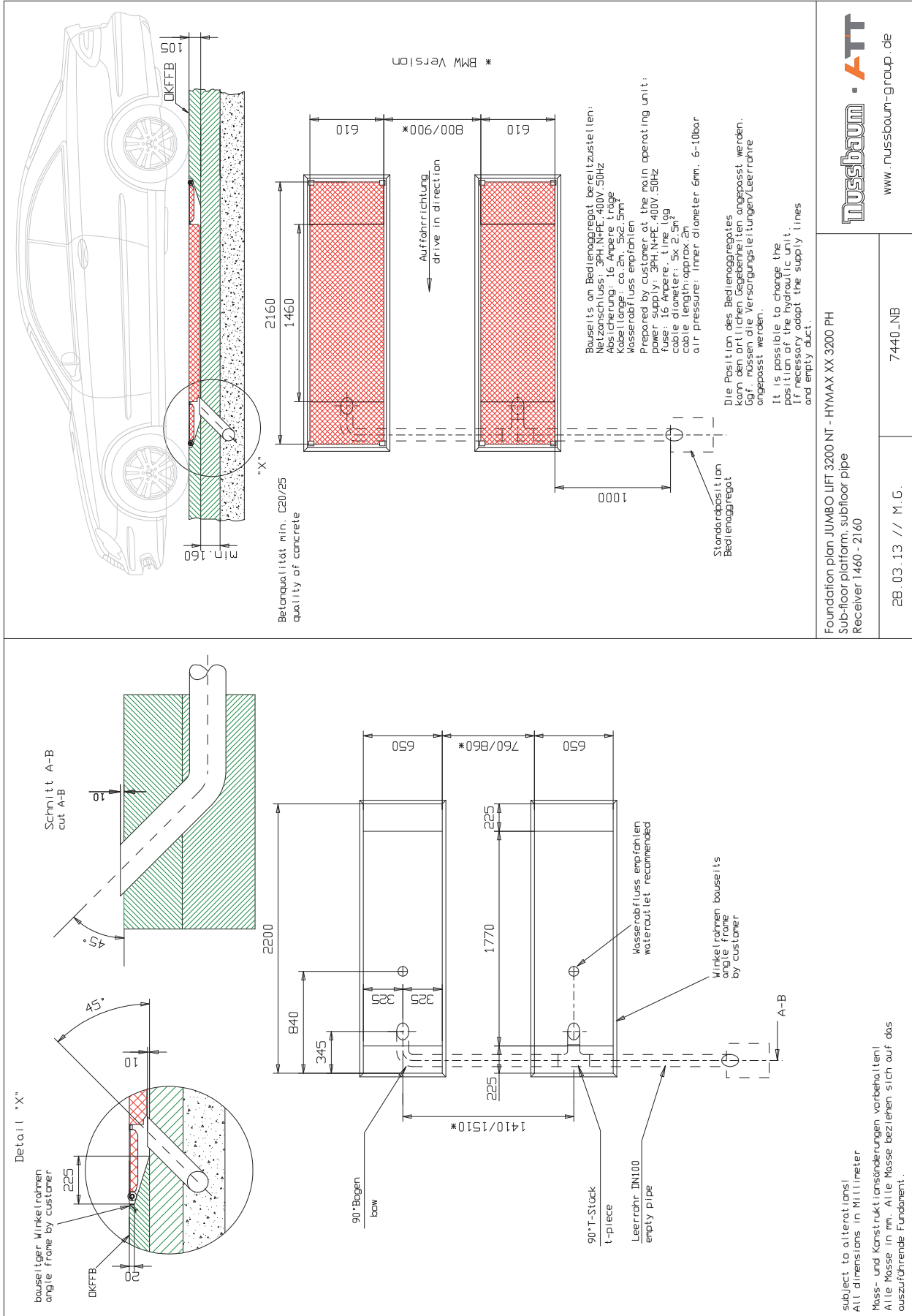

11.2 Above ground

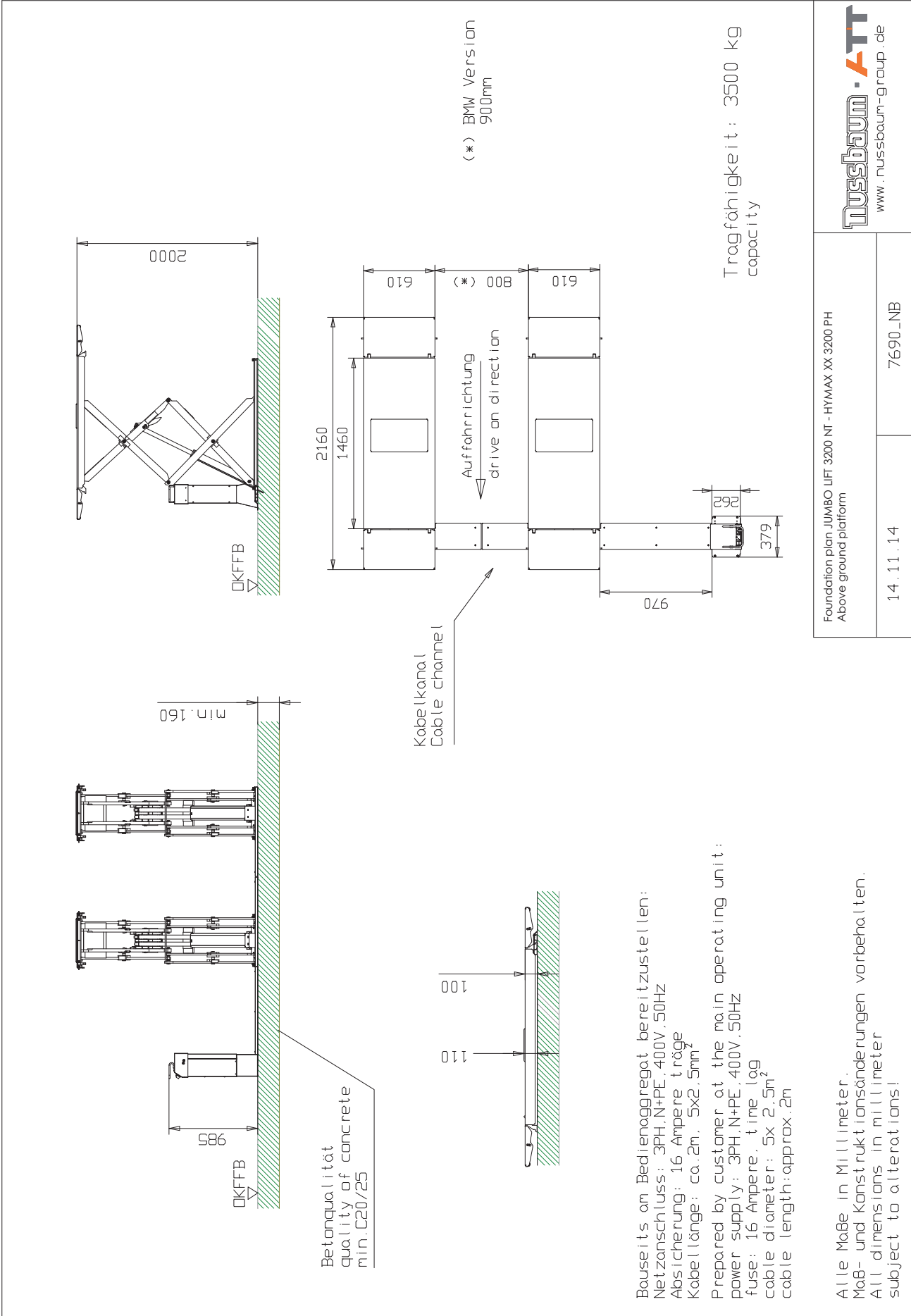

## 12 hydraulic plan

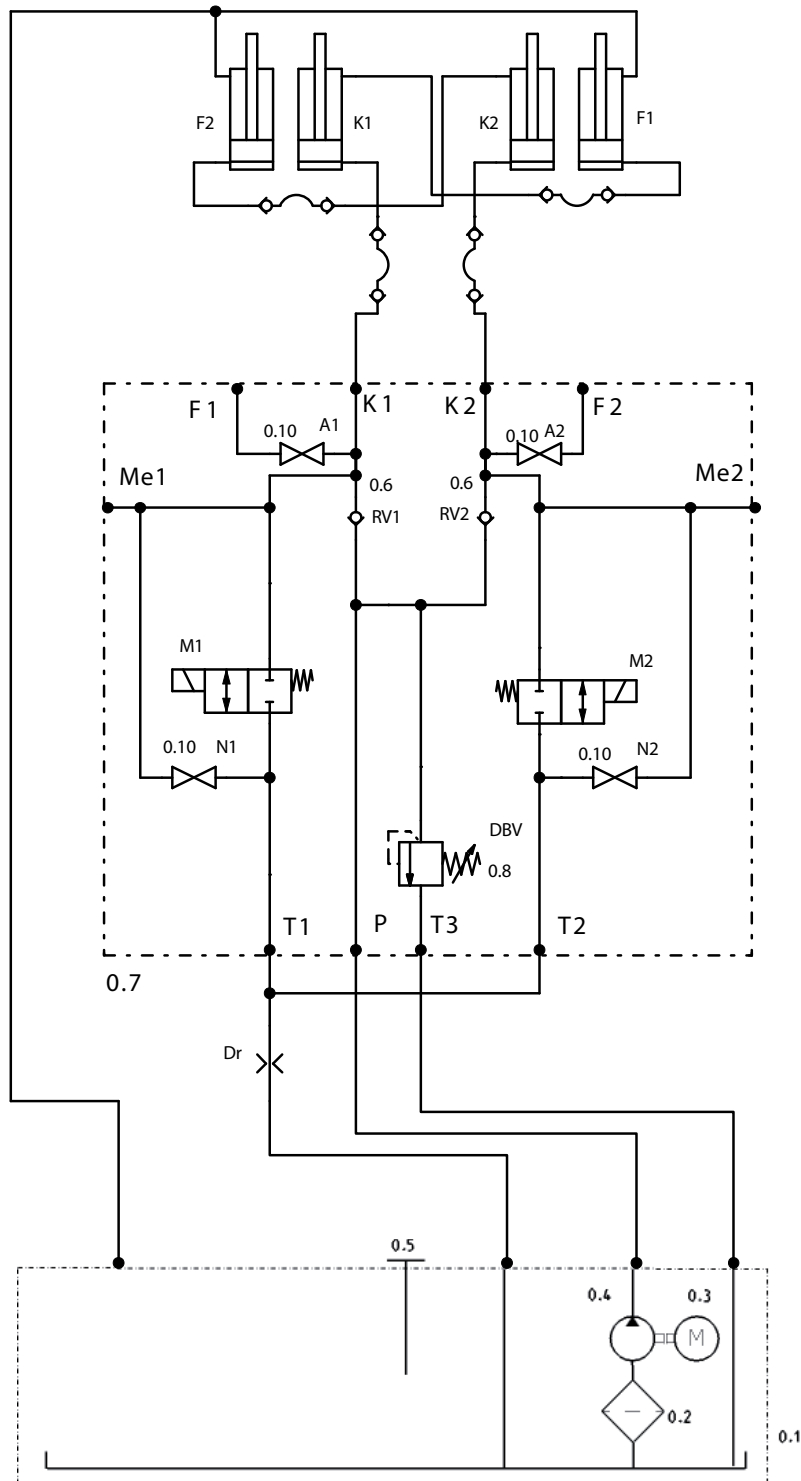

27.01.2015-30.01.2015 JUMBO LIFT HF 030JL82039 SBr

No.	Designation:	Drawing number	No.	Designation:	Drawing number
0.1	Oil container	030JL01353	0.7	Complete block	030JL82038
0.2	Suction filter	98012	0.8	Pressure relief valve	232NSTL02082
0.3	Mechanical pump	98340	0.9	Solenoid valve	9804781
0.4	Motor	992658	0.10	Emergency discharge screw	232TTL42038
0.5	Oil dipstick	982186			
0.6	Check valve	159604			



### 13 Replacement parts list

#### 10.xx Platform

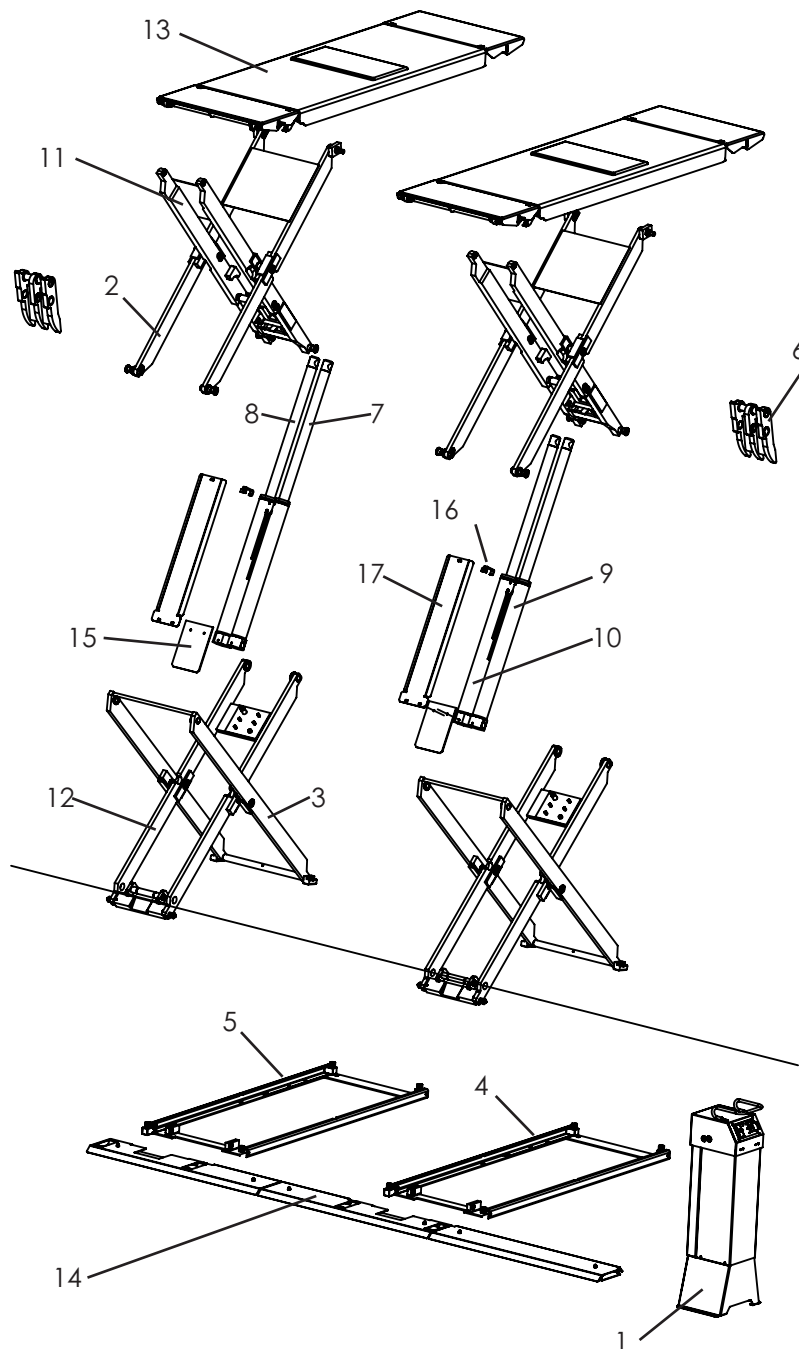

035ji00100\_3 17.03.2015

10.1	030JL21360	UNIT
10.2	035JL06031	EXTERIOR SCISSOR UPPER, COMPLETE
10.3	035JL06011	EXTERNAL SCISSOR LOWER, COMPLETE
10.4	035JL05210	FLOOR PANEL LEFT, COMPLETE
10.5	035JL05201	FLOOR PANEL RIGHT, COMPLETE
10.6	035JL06110	DOWNSTREAM CYLINDER LEVER, COMPLETE

- 
- 10.7 040JL02704 AUXILIARY ASSEMBLY PISTON ROD, DOWNSTREAM SIDE
- ! WE RECOMMEND THAT YOU SEND DEFECTIVE CYLINDERS TO US FOR REPAIR.  
CYLINDERS WILL BE INSPECTED AND SENT BACK!
- 
- 10.8 040JL02604 AUXILIARY GROUP PISTON ROD, COMMAND SIDE
- ! WE RECOMMEND THAT YOU SEND DEFECTIVE CYLINDERS TO US FOR REPAIR.  
CYLINDERS WILL BE INSPECTED AND SENT BACK!
- 
- 10.9 040JL02702 AUXILIARY GROUP CYLINDER PIPE, DOWNSTREAM SIDE
- ! WE RECOMMEND THAT YOU SEND DEFECTIVE CYLINDERS TO US FOR REPAIR.  
CYLINDERS WILL BE INSPECTED AND SENT BACK!
- 
- 10.10 040JL02602 AUXILIARY GROUP CYLINDER PIPE, COMMAND SIDE
- ! WE RECOMMEND THAT YOU SEND DEFECTIVE CYLINDERS TO US FOR REPAIR.  
CYLINDERS WILL BE INSPECTED AND SENT BACK!
- 
- 10.11 035JL06221 INTERIOR SCISSORS TOP
- 
- 10.12 035JL06101 SCISSORS LOWER
- 
- 10.13 035JL08401 RAIL 1460 MM LONG, COMPLETE
- 
- 10.14 030JL09530 HOSE COVER, COMPLETE
- 
- 10.15 040JL02629 RUBBER APRON
- 
- 10.16 040JL02631 CLAMP PANEL
- 
- 10.17 040JL02627 HOSE COVER FOR CYLINDER
-

20.xx Floor panel, right

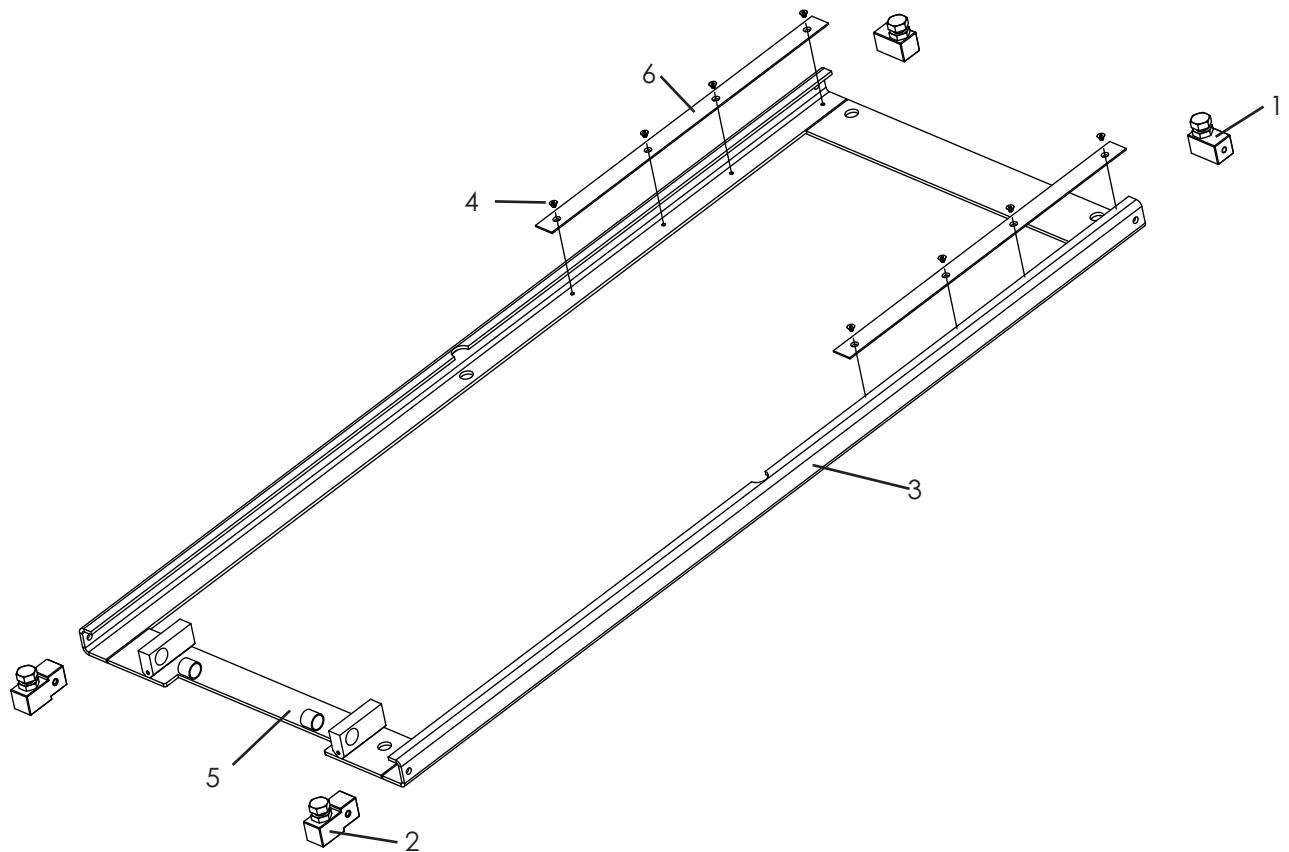

035jl05201\_2 17.03.2015

20.1	040JL05020	SPACER FOOT 1 COMPLETE
20.2	040JL05010	SPACER FOOT 2 COMPLETE
20.3	035JL05203	FLOOR PANEL, WELD PART
20.4	97991-M5X6	COUNTERSUNK SCREW
20.5	9PAP202320P10	DU JACK
20.6	030JL05008	RUNNING PANEL

30.xx Hose cover

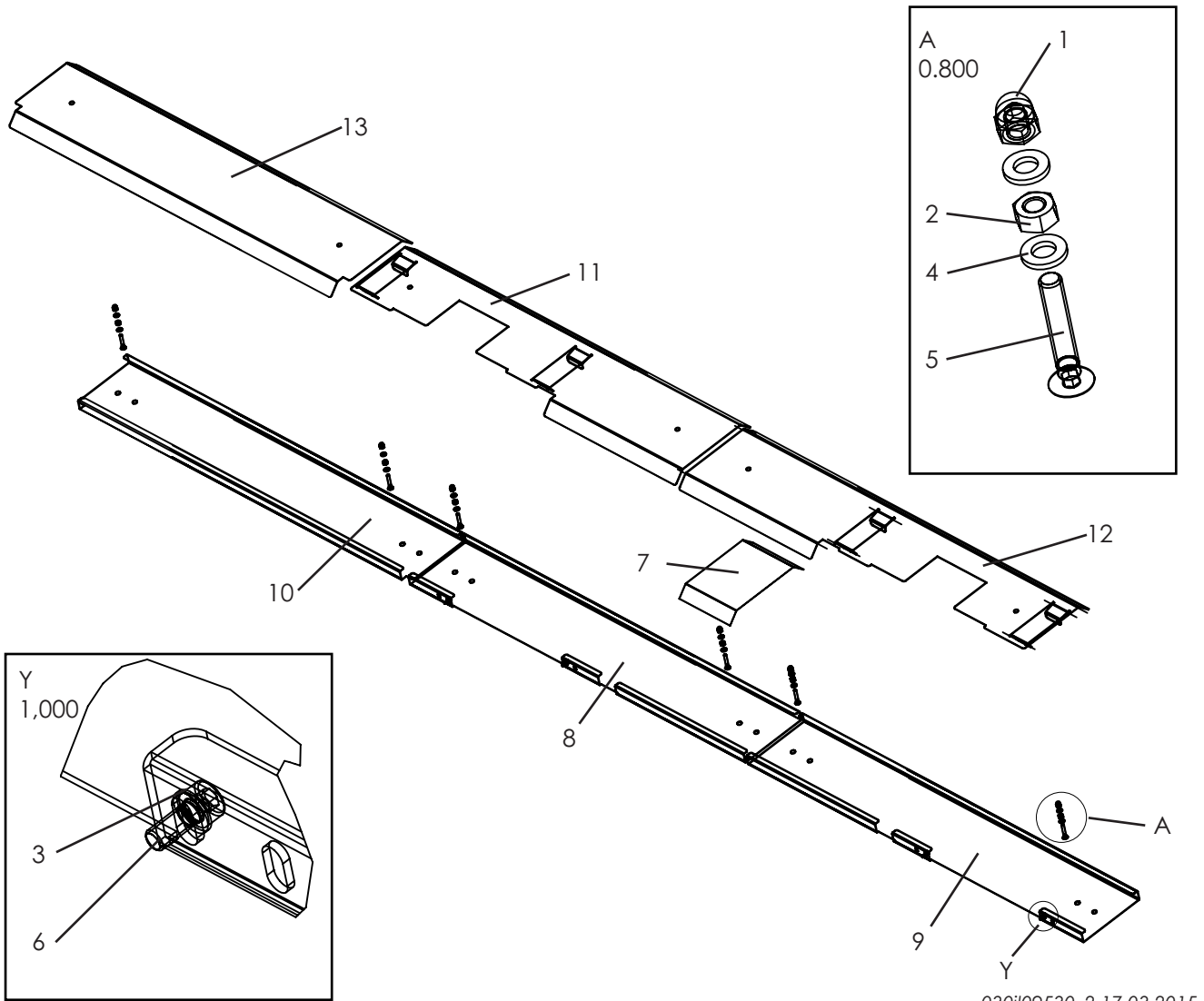

030jl09530\_2 17.03.2015

30.1	91587-M6	ACORN NUT
30.2	9934-M6	HEXAGONAL NUT
30.3	9125_1-A5_3	WASHER
30.4	9125_1-A6_4	WASHER
30.5	97991-M6X35	COUNTERSUNK SCREW
30.6	9912-M5X12	CYLINDER SCREW
30.7	030JL09552	BALANCE COVER
30.8	030JL09531	CABLE CONDUIT
30.9	030JL09533	CABLE CONDUIT
30.10	030JL09546	CABLE CONDUIT
30.11	030JL09541	CONDUIT COVER
30.12	030JL09542	CONDUIT COVER
30.13	030JL09548	CONDUIT COVER

40.xx Exterior scissors top

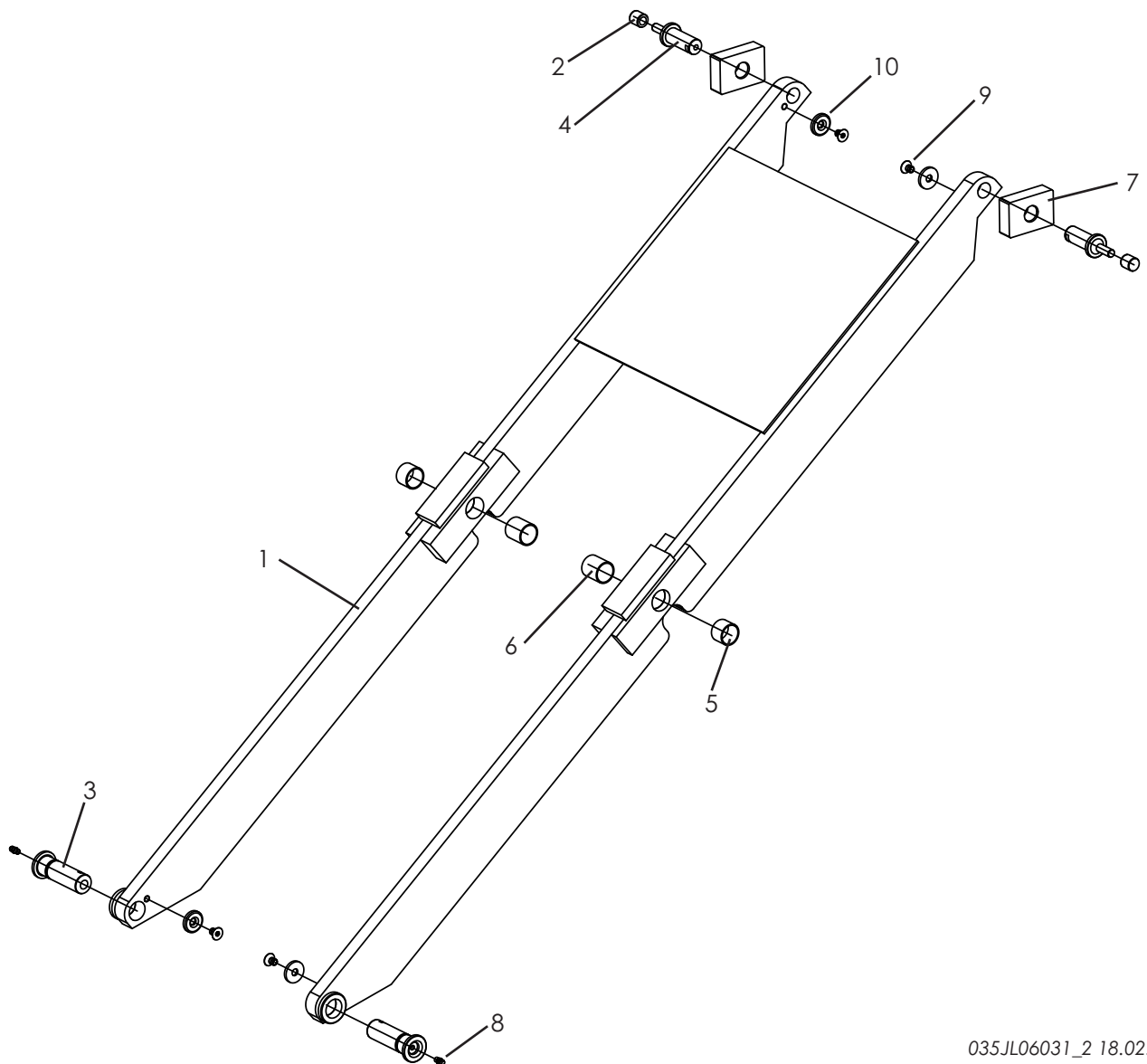

035JL06031\_2 18.02.2015

40.1	035JL06033	EXTERIOR SCISSORS TOP, WELD PART
40.2	030JL06166	START UP ROLLER
40.3	030JL26021	EXTERIOR BOLTS SCISSORS
40.4	030JL26165	EXTERIOR BOLTS SCISSORS
40.5	9PAP252820P10	DU JACK
40.6	9PAP252830P10	DU JACK
40.7	030JL26168	SLIDING PIECE TOP
40.8	971412-AM6	BALL LUBRICATION NIPPLE
40.9	97991-M8X12	COUNTERSUNK SCREW
40.10	030JL22023	LOCKING WASHER

**50.xx Exterior scissors lower**

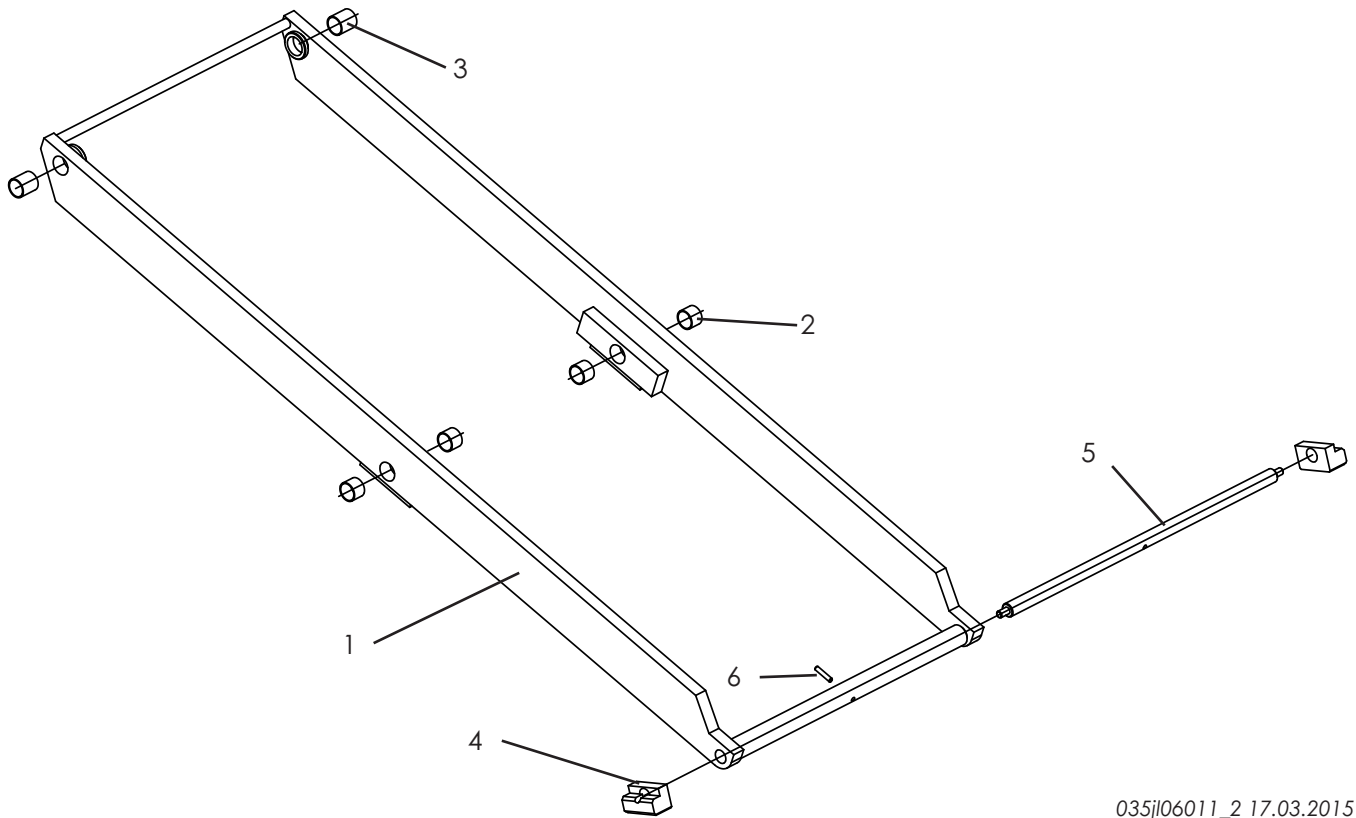

035jl06011\_2 17.03.2015

50.1	035JL06013	EXTERIOR RAIL LOWER, WELD PART
50.2	9PAP252820P10	DU JACK
50.3	9PAP252830P10	DU JACK
50.4	035JL06017	SLIDING PIECE LOWER EXTERIOR
50.5	030JL06112	SLIDING PIECE AXIS
50.6	91481-6X30	FRICTION BOLT

60.xx Scissors lower

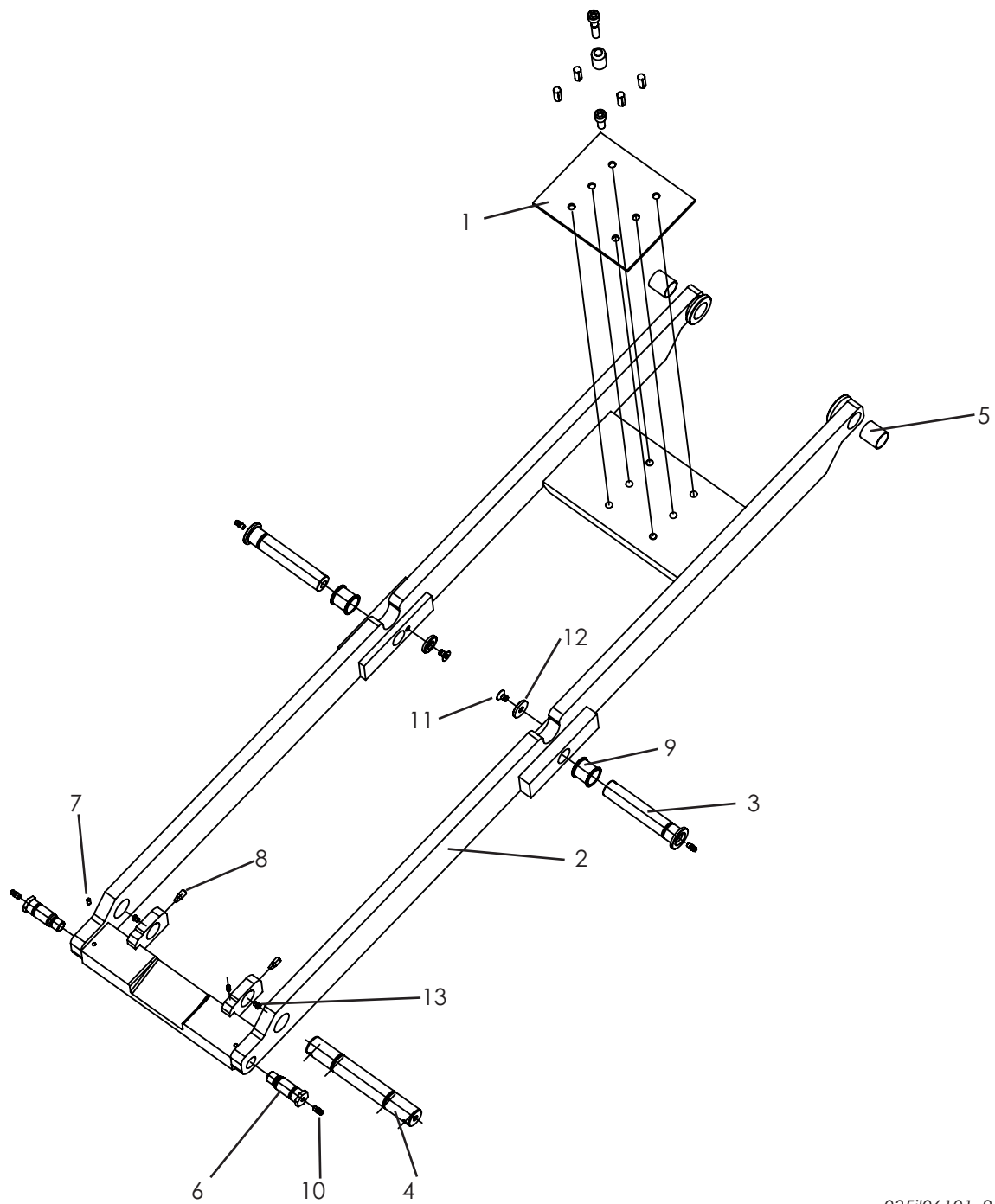

035jl06101\_2 17.03.2015

60.1	030JL66014	PRESSURE PLATE SET
60.2	035JL06103	SCISSORS, WELD PART
60.3	030JL26024	EXTERIOR BOLTS SCISSORS
60.4	030JL62021	CYLINDER BOLTS LOWER
60.5	9PAP252830P10	DU JACK
60.6	030JL05012	FIXED BEARING BOLTS
60.7	9914-M5X12	SET SCREW
60.8	030JL66028	SET SCREW

60.9	030JL06030	SLEEVE
60.10	971412-AM6	BALL LUBRICATION NIPPLE
60.11	97991-M8X12	COUNTERSUNK SCREW
60.12	030JL22023	LOCKING WASHER
60.13	970554	LUBRICATION NIPPLE FUNNEL, STRAIGHT

**70.xx Interior scissors top**

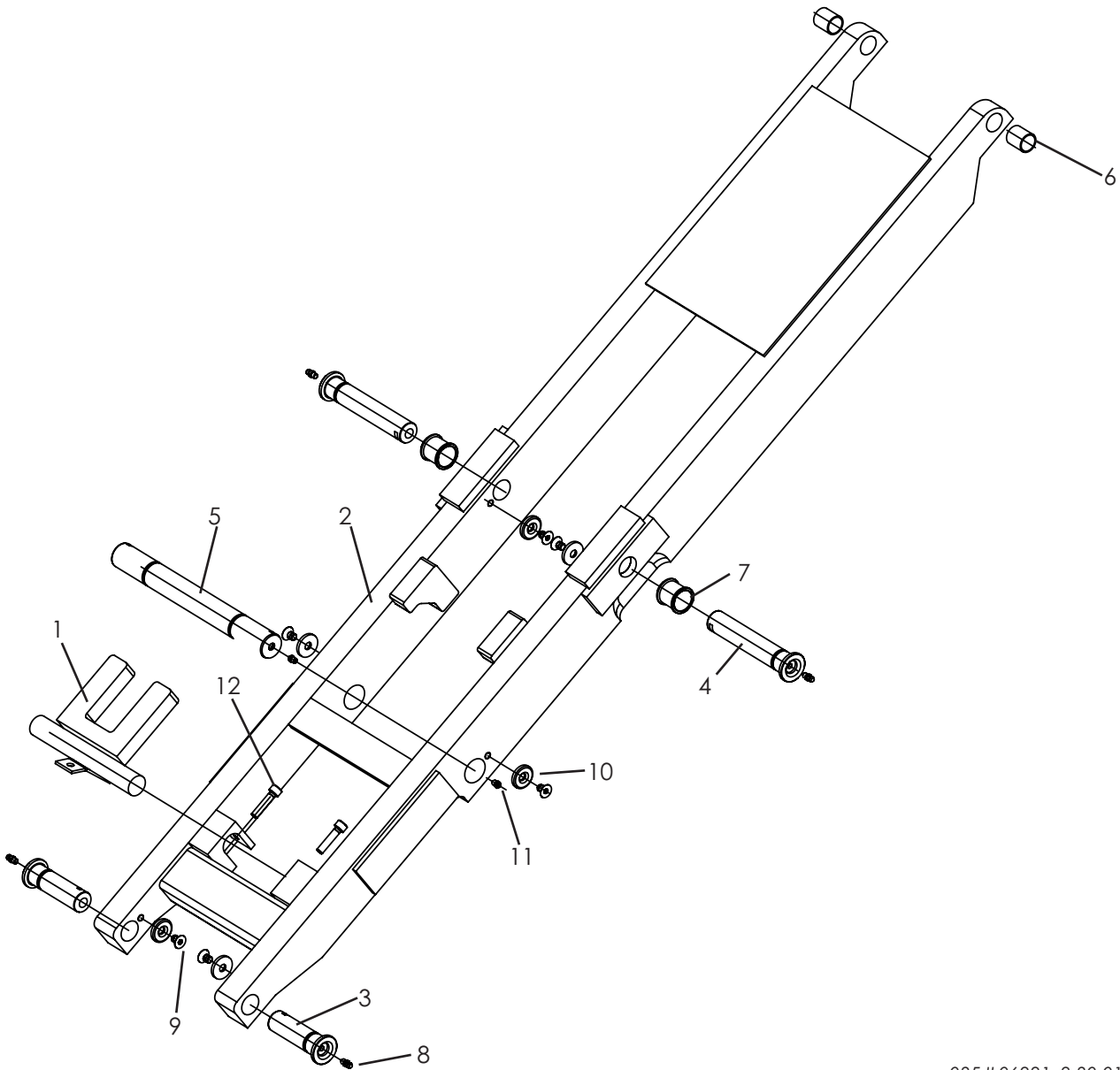

035JL06221\_2 30.01.2015

70.1	030JL66093	BLOCKING, WELD PART
70.2	035JL06223	INTERIOR SCISSORS TOP
70.3	030JL26022	EXTERIOR BOLTS SCISSORS



---

70.4	030JL26025	EXTERIOR BOLTS SCISSORS
70.5	030JL66090	ZE BOLTS
70.6	9PAP202325P10	DU JACK
70.7	030JL06030	SLEEVE
70.8	971412-AM6	BALL LUBRICATION NIPPLE
70.9	97991-M8X12	COUNTERSUNK SCREW
70.10	030JL22023	LOCKING WASHER
70.11	970554	LUBRICATION NIPPLE FUNNEL
70.12	9912-M8X35	CYLINDER SCREW

---

**80.xx Rail**

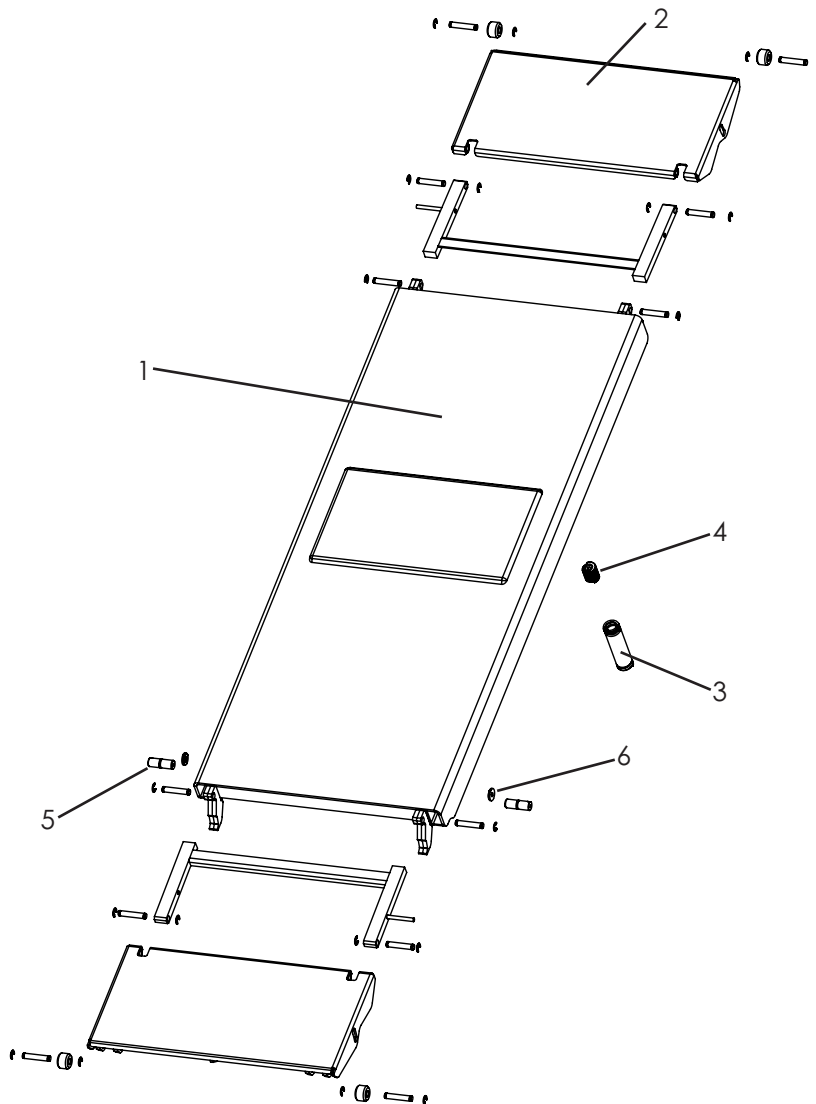

035JL08401\_3 30.03.2015 IG

---

80.1	035JL08401	RAIL 1460 MM LONG, COMPLETE
------	------------	-----------------------------

80.2	030JL38719	RAMPS 300 MM LONG, COMPLETE
80.3	035JL08403	RAMP, WELD PART
80.4	025SPB06165	SPRING HOLDER
80.5	030JL22023	LOCKING WASHER
80.6	030JL68019	FESTLAGERBOLZEN SCHIENE
80.7	9DFD-357A2ZN	PRESSURE SPRING

**90.xx Ramps**

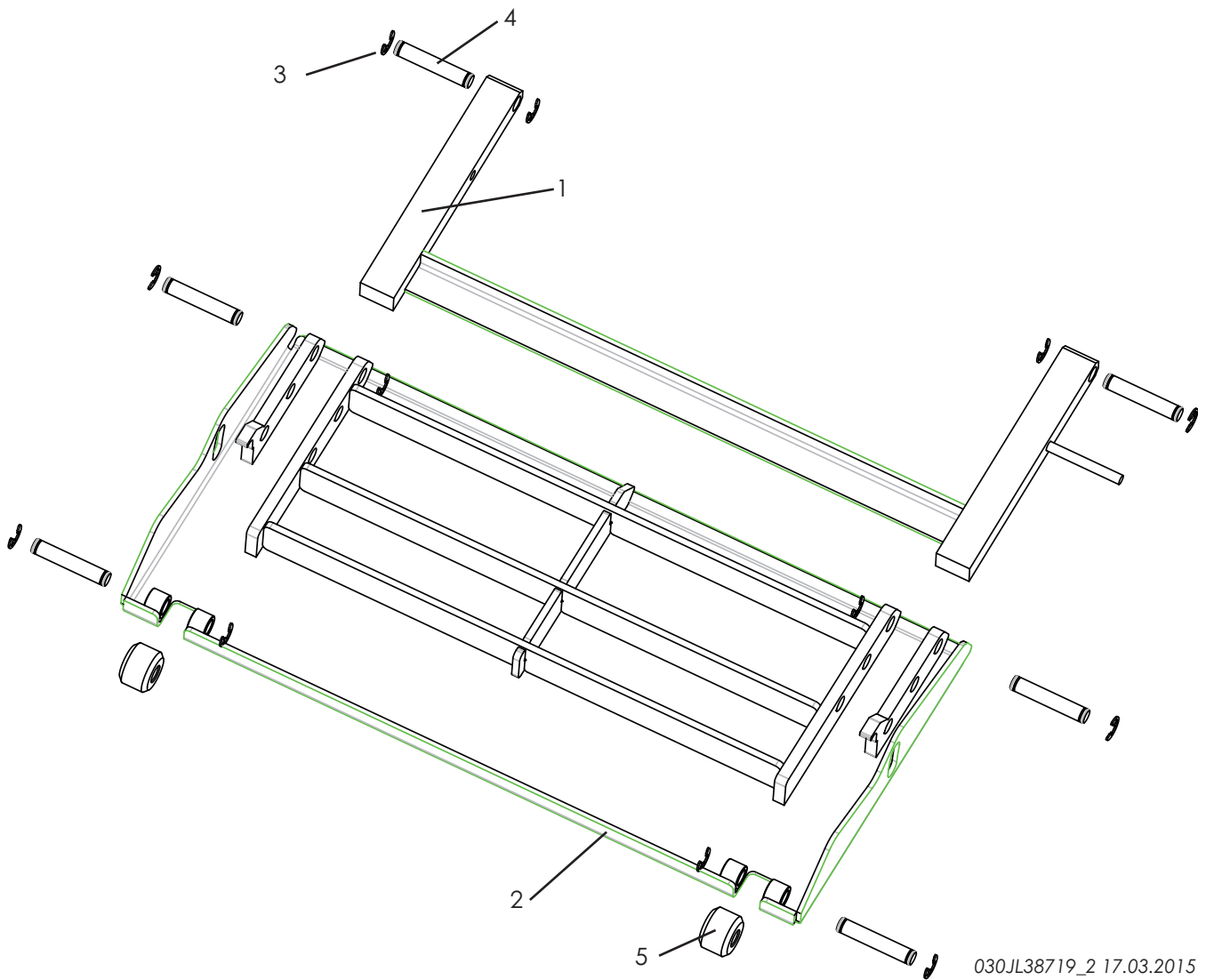

030JL38719\_2 17.03.2015

90.1	030JL38618	COMPLETE LEVER, WELD PART
90.2	030JL38720	RAMP, WELD PART 300 MM LONG
90.3	96799 -10	LOCKING WASHER
90.4	025SPB68627	BOLTS RD 12X66
90.5	025SPB68628	ROLLER

100.xx Unit

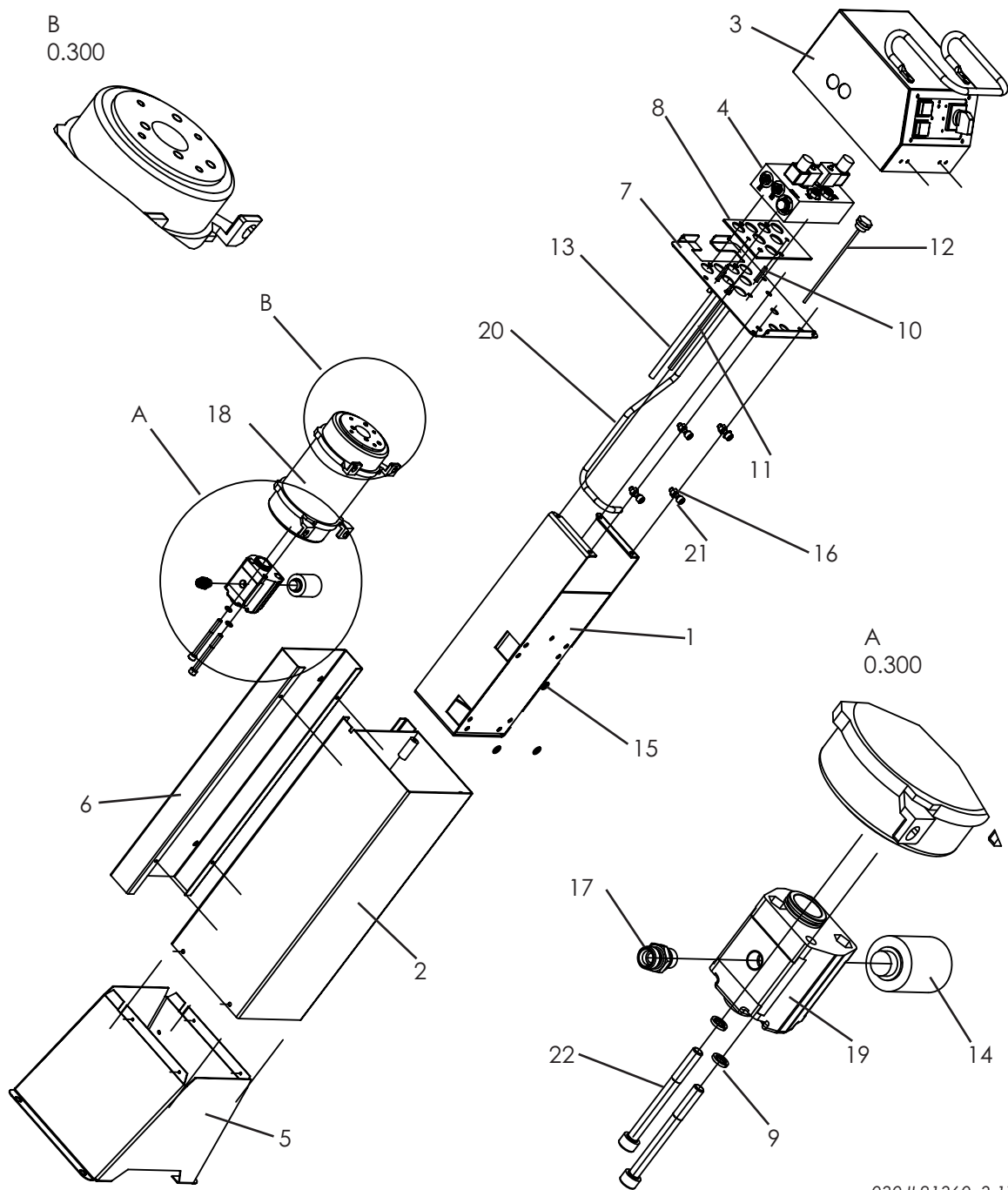

030JL21360\_3 17.03.2015

100.1	030JL01320	RECEIVING PANEL, WELD PART
100.2	030JL01353	HOLDER, WELD PART
100.3	030JL41330	COMPLETE COVER
100.4	030JL82038	COMPLETE HYDRAULIC BLOCK
100.5	030JL21361	PEDESTAL, WELD PART
100.6	030JL01308	REAR COVER
100.7	030JL41306	COVER PLATE
100.8	030JL01362	SEAL FOR BLOCK

---

100.9	97980 -8	SPRING WASHER
100.10	030JL01364	HYDRAULIC PIPE
100.11	030JL01366	HYDRAULIC PIPE DM. 8
100.12	982186	OIL DIPSTICK
100.13	030JL21342	RETURN LINE
100.14	980012	SUCTION FILTER
100.15	9125_1-A8_4	WASHER
100.16	9934-M8	HEXAGONAL NUT
100.17	93901-L10A-M	SUPPORTS
100.18	992658	UNDER OIL MOTOR
100.19	980340	MECHANICAL PUMP
100.20	030JL21344	SUPPLY
100.21	9912-M8X25	CYLINDER SCREW
100.22	9912-M8X85	CYLINDER SCREW

---

110.xx Hydraulic block

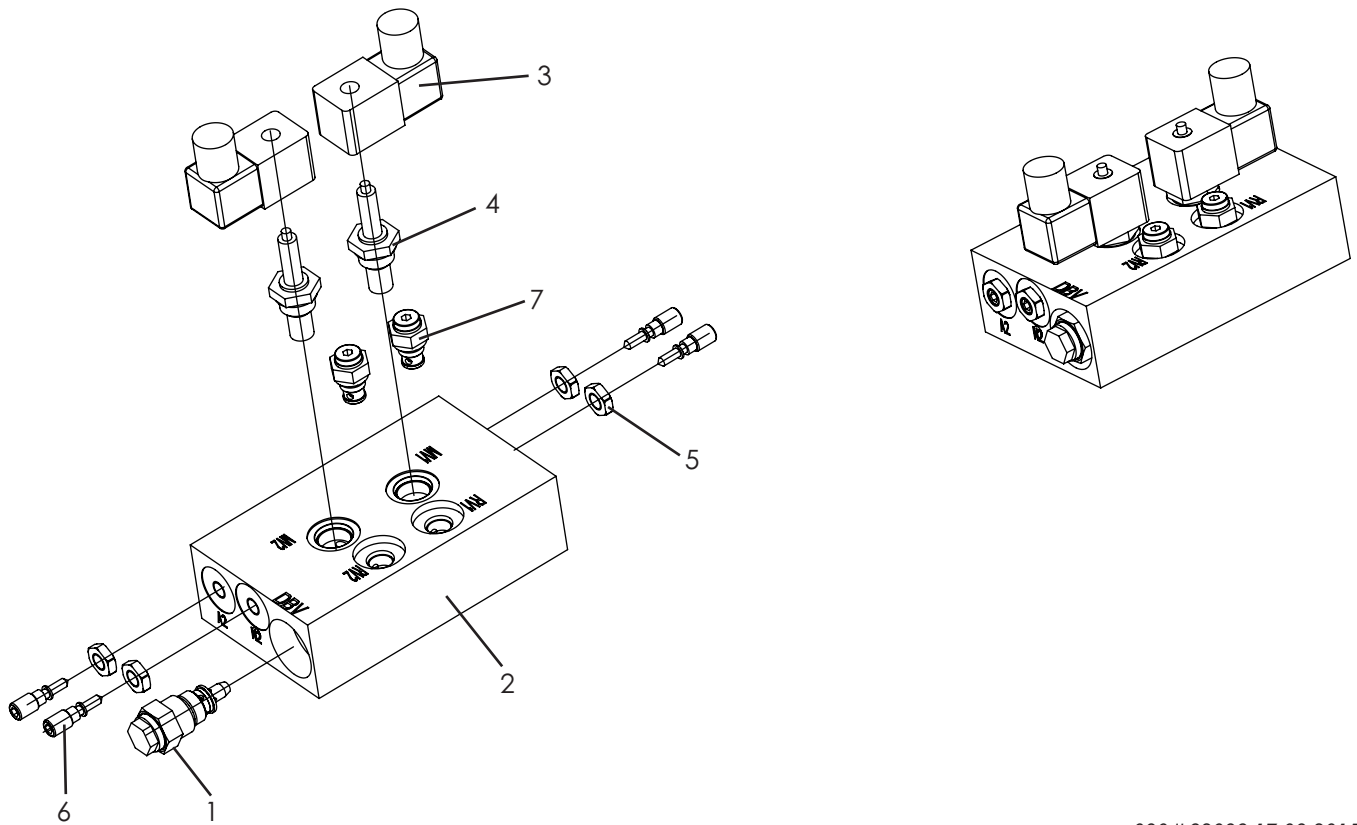

030JL82038 17.03.2015

110.1	232NSTL02082	PRESSURE RELIEF VALVE
110.2	030JL82039	HYDRAULIC BLOCK
110.3	980630	MAGNETIC COIL
110.4	980478	SOLENOID VALVE WITHOUT SIEVE
110.5	9MU439M10ZN	HEXAGONAL NUT
110.6	232TTL42038	EMERGENCY DISCHARGE
110.7	980480	CHECK VALVE

## 120.xx Hydraulic hose sets

120.1	035JL01490	HOSE SET, STANDARD V1 WITH OVERFLOWS FOR ABOVE FLOOR USE (HYPERFLOW)
120.2	983652	HOSE, 2SC, DN06X2100, DKOL-DKOL
120.3	983655	HOSE, 2SC, DN06X3400, DKOL, DKOL
120.4	983662	HOSE, 2SC, DN06X2100, CEL, CELM12X1,5
120.5	983662.1	HOSE, 2SC, DN06X2100, CEL, CELM12X1,5
120.6	983663	HOSE, 2SC, DN06X2650, CEL, DKOL 90°
120.7	983664	HOSE, 2SC, DN06X1180, CEL, DKOL
120.8	980936	HOSE, 2SC, DN06X0450, CEL, CEL12X1.5SHAPEB

120.9	035JL01491	HOSE SET, STANDARD V2 WITH OVERFLOWS FOR SUB-FLOOR USE (HYPERFLOW)
120.10	983652	HOSE, 2SC, DN06X2100, DKOL-DKOL
120.11	983655	HOSE, 2SC, DN06X3400, DKOL, DKOL
120.12	983662	HOSE, 2SC, DN06X2100, CEL, CELM12X1,5
120.13	983662.1	HOSE, 2SC, DN06X2100, CEL, CELM12X1,5
120.14	983665	HOSE, 2SC, DN06X2750, DKOL, DKOL
120.15	983666	HOSE, 2SC, DN06X4150, DKOL, DKOL
120.16	980936	HOSE, 2SC, DN06X0450, CEL, CEL12X1.5SHAPEB

120.17	035JL01492	HOSE SET STANDARD WITH OVERFLOWS FOR BMW (HYPERFLOW)
120.18	983658	HOSE, 2SC, DN06X6350, DKOL, DKOL
120.19	982132	HOSE, 2SC, DN06X7700, DKOL, DKOL
120.20	983662	HOSE, 2SC, DN06X2100, CEL, CELM12X1,5
120.21	983662.1	HOSE, 2SC, DN06X2100, CEL, CELM12X1,5
120.22	983659	HOSE, 2SC, DN06X7100, DKOL, DKOL
120.23	983660	HOSE, 2SC, DN06X8500, DKOL, DKOL
120.24	980936	HOSE, 2SC, DN06X0450, CEL, CEL12X1.5SHAPEB

## 14 Set up protocol

ii After successful set up, complete this form fully, sign it, make a copy and send to the manufacturer within a week.

Otto Nußbaum GmbH & Co.KG  
Korker Straße 24  
D-77694 Kehl-Bodersweier

The system with serial number \_\_\_\_\_ was set up on (date) \_\_\_\_\_ at  
(company name) \_\_\_\_\_ in (town, city) \_\_\_\_\_  
\_\_\_\_\_ checked for function and safety and put into operation. .

The set up was done by the operating company / specialist (score out the one that does not apply).

The operating company confirms proper system set up, has read and will comply with all information contained in this operating manual and inspection book, and will keep this document accessible to trained operators at all times.

The specialist confirms proper system set up, has read all information in this operating manual and inspection book, and has transferred the documents to the operating company.

\_\_\_\_\_  
Date Name, Operating company & company stamp Operating company signature

\_\_\_\_\_  
Date Name, Specialist Specialist signature

Service partner: \_\_\_\_\_  
Stamp

Only fill out if the system has a fixed anchor.

Anchor used \*) \_\_\_\_\_  
Type/ brand

Minimum anchor depth \*) complied with: \_\_\_\_\_ mm

Tightening torque \*) complied with: \_\_\_\_\_ Nm

\*) See 4.2.1 selecting the anchor

## 14.1 Transfer protocol

The system \_\_\_\_\_ with serial number \_\_\_\_\_  
was set up on (date) \_\_\_\_\_ at (company name) \_\_\_\_\_  
in (town, city) \_\_\_\_\_ checked for function and safety and put into operation.

The following listed people (operators) were trained to handle the lift after it was set up by a trained assembler of the manufacturer or a contract partner (specialist).

(Date, name, signature, empty lines must have a scored out)

_____	_____	_____
<i>Date</i>	<i>Name</i>	<i>Signature</i>

_____	_____	_____
<i>Date</i>	<i>Name</i>	<i>Signature</i>

_____	_____	_____
<i>Date</i>	<i>Name</i>	<i>Signature</i>

_____	_____	_____
<i>Date</i>	<i>Name</i>	<i>Signature</i>

_____	_____	_____
<i>Date</i>	<i>Name</i>	<i>Signature</i>

_____	_____	_____
<i>Date</i>	<i>Name, specialist</i>	<i>Signature of specialist</i>

Service partner: \_\_\_\_\_ (Stamp)



## 15 Safety inspection

### 15.1 Single safety inspection before commissioning

 Copy, complete and leave in the inspection book

Serial number: \_\_\_\_\_

Test step	OK	Defective or Missing	Retest	Remarks
Model plate _____	<input type="checkbox"/>	<input type="checkbox"/>	<input type="checkbox"/>	_____
Operating manual _____	<input type="checkbox"/>	<input type="checkbox"/>	<input type="checkbox"/>	_____
Load capacity details on the system _____	<input type="checkbox"/>	<input type="checkbox"/>	<input type="checkbox"/>	_____
Main switch function _____	<input type="checkbox"/>	<input type="checkbox"/>	<input type="checkbox"/>	_____
Function button "LIFT, LOWER" _____	<input type="checkbox"/>	<input type="checkbox"/>	<input type="checkbox"/>	_____
General system condition _____	<input type="checkbox"/>	<input type="checkbox"/>	<input type="checkbox"/>	_____
Condition / function of foot bumper (optional) _____	<input type="checkbox"/>	<input type="checkbox"/>	<input type="checkbox"/>	_____
Condition/ function ramps / rollers _____	<input type="checkbox"/>	<input type="checkbox"/>	<input type="checkbox"/>	_____
Securing the bolts _____	<input type="checkbox"/>	<input type="checkbox"/>	<input type="checkbox"/>	_____
Condition of bolts and bearing seating _____	<input type="checkbox"/>	<input type="checkbox"/>	<input type="checkbox"/>	_____
Load bearing construction (deformations, cracks) _____	<input type="checkbox"/>	<input type="checkbox"/>	<input type="checkbox"/>	_____
Unit condition _____	<input type="checkbox"/>	<input type="checkbox"/>	<input type="checkbox"/>	_____
Cover conditions _____	<input type="checkbox"/>	<input type="checkbox"/>	<input type="checkbox"/>	_____
Paint condition _____	<input type="checkbox"/>	<input type="checkbox"/>	<input type="checkbox"/>	_____
Condition piston rods and wipers _____	<input type="checkbox"/>	<input type="checkbox"/>	<input type="checkbox"/>	_____
Hydraulic system leak-tightness _____	<input type="checkbox"/>	<input type="checkbox"/>	<input type="checkbox"/>	_____
Hydraulic oil filling level _____	<input type="checkbox"/>	<input type="checkbox"/>	<input type="checkbox"/>	_____
Hydraulic line conditions _____	<input type="checkbox"/>	<input type="checkbox"/>	<input type="checkbox"/>	_____
Condition hydraulic screw fittings _____	<input type="checkbox"/>	<input type="checkbox"/>	<input type="checkbox"/>	_____
Condition electrical lines _____	<input type="checkbox"/>	<input type="checkbox"/>	<input type="checkbox"/>	_____
Condition of weld seams _____	<input type="checkbox"/>	<input type="checkbox"/>	<input type="checkbox"/>	_____
Fastening anchor torque _____	<input type="checkbox"/>	<input type="checkbox"/>	<input type="checkbox"/>	_____
Fastening screw torque _____	<input type="checkbox"/>	<input type="checkbox"/>	<input type="checkbox"/>	_____
Condition of polymer overlays _____	<input type="checkbox"/>	<input type="checkbox"/>	<input type="checkbox"/>	_____
Condition of concrete floor (cracks) _____	<input type="checkbox"/>	<input type="checkbox"/>	<input type="checkbox"/>	_____
Function CE stop and warning signal (optional) _____	<input type="checkbox"/>	<input type="checkbox"/>	<input type="checkbox"/>	_____
Function balance of rails _____	<input type="checkbox"/>	<input type="checkbox"/>	<input type="checkbox"/>	_____
Functional test, system with load _____	<input type="checkbox"/>	<input type="checkbox"/>	<input type="checkbox"/>	_____

\*) Place a checkmark in the relevant, if a retest is required then check it again!

Safety inspection done on: \_\_\_\_\_

Performed by company: \_\_\_\_\_

Name, address of specialist: \_\_\_\_\_

- Result of inspection:
- Continued operation questionable, reinspection required
  - Continued operation possible, remove defects by \_\_\_\_\_
  - No deficiencies, continue to operate

\_\_\_\_\_  
Signature of specialist

\_\_\_\_\_  
Operating company signature

If requested to take care of deficiencies

Deficiency removed on: \_\_\_\_\_

\_\_\_\_\_  
Operating company signature

(use a new form for reinspection!)

## 15.2 Regular safety inspection and maintenance

 Copy, complete and leave in the inspection book

Serial number: \_\_\_\_\_

Test step	OK	Defective or Missing	Retest	Remarks
Model plate _____	<input type="checkbox"/>	<input type="checkbox"/>	<input type="checkbox"/>	_____
Operating manual _____	<input type="checkbox"/>	<input type="checkbox"/>	<input type="checkbox"/>	_____
Load capacity details on the system _____	<input type="checkbox"/>	<input type="checkbox"/>	<input type="checkbox"/>	_____
Main switch function _____	<input type="checkbox"/>	<input type="checkbox"/>	<input type="checkbox"/>	_____
Function button "LIFT, LOWER" _____	<input type="checkbox"/>	<input type="checkbox"/>	<input type="checkbox"/>	_____
General system condition _____	<input type="checkbox"/>	<input type="checkbox"/>	<input type="checkbox"/>	_____
Condition / function of foot bumper (optional) _____	<input type="checkbox"/>	<input type="checkbox"/>	<input type="checkbox"/>	_____
Condition/ function ramps / rollers _____	<input type="checkbox"/>	<input type="checkbox"/>	<input type="checkbox"/>	_____
Securing the bolts _____	<input type="checkbox"/>	<input type="checkbox"/>	<input type="checkbox"/>	_____
Condition of bolts and bearing seating _____	<input type="checkbox"/>	<input type="checkbox"/>	<input type="checkbox"/>	_____
Load bearing construction (deformations, cracks) _____	<input type="checkbox"/>	<input type="checkbox"/>	<input type="checkbox"/>	_____
Unit condition _____	<input type="checkbox"/>	<input type="checkbox"/>	<input type="checkbox"/>	_____
Cover conditions _____	<input type="checkbox"/>	<input type="checkbox"/>	<input type="checkbox"/>	_____
Paint condition _____	<input type="checkbox"/>	<input type="checkbox"/>	<input type="checkbox"/>	_____
Condition piston rods and wipers _____	<input type="checkbox"/>	<input type="checkbox"/>	<input type="checkbox"/>	_____
Hydraulic system leak-tightness _____	<input type="checkbox"/>	<input type="checkbox"/>	<input type="checkbox"/>	_____
Hydraulic oil filling level _____	<input type="checkbox"/>	<input type="checkbox"/>	<input type="checkbox"/>	_____
Hydraulic line conditions _____	<input type="checkbox"/>	<input type="checkbox"/>	<input type="checkbox"/>	_____
Condition hydraulic screw fittings _____	<input type="checkbox"/>	<input type="checkbox"/>	<input type="checkbox"/>	_____
Condition electrical lines _____	<input type="checkbox"/>	<input type="checkbox"/>	<input type="checkbox"/>	_____
Condition of weld seams _____	<input type="checkbox"/>	<input type="checkbox"/>	<input type="checkbox"/>	_____
Fastening anchor torque _____	<input type="checkbox"/>	<input type="checkbox"/>	<input type="checkbox"/>	_____
Fastening screw torque _____	<input type="checkbox"/>	<input type="checkbox"/>	<input type="checkbox"/>	_____
Condition of polymer overlays _____	<input type="checkbox"/>	<input type="checkbox"/>	<input type="checkbox"/>	_____
Condition of concrete floor (cracks) _____	<input type="checkbox"/>	<input type="checkbox"/>	<input type="checkbox"/>	_____
Function CE stop and warning signal (optional) _____	<input type="checkbox"/>	<input type="checkbox"/>	<input type="checkbox"/>	_____
Function balance of rails _____	<input type="checkbox"/>	<input type="checkbox"/>	<input type="checkbox"/>	_____
Functional test, system with load _____	<input type="checkbox"/>	<input type="checkbox"/>	<input type="checkbox"/>	_____

*\*) Place a checkmark in the relevant, if a retest is required then check it again!*

Safety inspection done on: \_\_\_\_\_

Performed by company: \_\_\_\_\_

Name, address of specialist: \_\_\_\_\_

- Result of inspection:
- Continued operation questionable, reinspection required
  - Continued operation possible, remove defects by \_\_\_\_\_
  - No deficiencies, continue to operate

\_\_\_\_\_  
*Signature of specialist*

\_\_\_\_\_  
*Operating company signature*

If requested to take care of deficiencies

Deficiency removed on: \_\_\_\_\_

\_\_\_\_\_  
*Operating company signature*

*(use a new form for reinspection!)*

### 15.3 Exceptional safety inspection

 Copy, complete and leave in the inspection book

Serial number: \_\_\_\_\_

Test step	OK	Defective or Missing	Retest	Remarks
Model plate _____	<input type="checkbox"/>	<input type="checkbox"/>	<input type="checkbox"/>	_____
Operating manual _____	<input type="checkbox"/>	<input type="checkbox"/>	<input type="checkbox"/>	_____
Load capacity details on the system _____	<input type="checkbox"/>	<input type="checkbox"/>	<input type="checkbox"/>	_____
Main switch function _____	<input type="checkbox"/>	<input type="checkbox"/>	<input type="checkbox"/>	_____
Function button "LIFT, LOWER" _____	<input type="checkbox"/>	<input type="checkbox"/>	<input type="checkbox"/>	_____
General system condition _____	<input type="checkbox"/>	<input type="checkbox"/>	<input type="checkbox"/>	_____
Condition / function of foot bumper (optional) _____	<input type="checkbox"/>	<input type="checkbox"/>	<input type="checkbox"/>	_____
Condition/ function ramps / rollers _____	<input type="checkbox"/>	<input type="checkbox"/>	<input type="checkbox"/>	_____
Securing the bolts _____	<input type="checkbox"/>	<input type="checkbox"/>	<input type="checkbox"/>	_____
Condition of bolts and bearing seating _____	<input type="checkbox"/>	<input type="checkbox"/>	<input type="checkbox"/>	_____
Load bearing construction (deformations, cracks) _____	<input type="checkbox"/>	<input type="checkbox"/>	<input type="checkbox"/>	_____
Unit condition _____	<input type="checkbox"/>	<input type="checkbox"/>	<input type="checkbox"/>	_____
Cover conditions _____	<input type="checkbox"/>	<input type="checkbox"/>	<input type="checkbox"/>	_____
Paint condition _____	<input type="checkbox"/>	<input type="checkbox"/>	<input type="checkbox"/>	_____
Condition piston rods and wipers _____	<input type="checkbox"/>	<input type="checkbox"/>	<input type="checkbox"/>	_____
Hydraulic system leak-tightness _____	<input type="checkbox"/>	<input type="checkbox"/>	<input type="checkbox"/>	_____
Hydraulic oil filling level _____	<input type="checkbox"/>	<input type="checkbox"/>	<input type="checkbox"/>	_____
Hydraulic line conditions _____	<input type="checkbox"/>	<input type="checkbox"/>	<input type="checkbox"/>	_____
Condition hydraulic screw fittings _____	<input type="checkbox"/>	<input type="checkbox"/>	<input type="checkbox"/>	_____
Condition electrical lines _____	<input type="checkbox"/>	<input type="checkbox"/>	<input type="checkbox"/>	_____
Condition of weld seams _____	<input type="checkbox"/>	<input type="checkbox"/>	<input type="checkbox"/>	_____
Fastening anchor torque _____	<input type="checkbox"/>	<input type="checkbox"/>	<input type="checkbox"/>	_____
Fastening screw torque _____	<input type="checkbox"/>	<input type="checkbox"/>	<input type="checkbox"/>	_____
Condition of polymer overlays _____	<input type="checkbox"/>	<input type="checkbox"/>	<input type="checkbox"/>	_____
Condition of concrete floor (cracks) _____	<input type="checkbox"/>	<input type="checkbox"/>	<input type="checkbox"/>	_____
Function CE stop and warning signal (optional) _____	<input type="checkbox"/>	<input type="checkbox"/>	<input type="checkbox"/>	_____
Function balance of rails _____	<input type="checkbox"/>	<input type="checkbox"/>	<input type="checkbox"/>	_____
Functional test, system with load _____	<input type="checkbox"/>	<input type="checkbox"/>	<input type="checkbox"/>	_____

*\*) Place a checkmark in the relevant, if a retest is required then check it again!*

Safety inspection done on: \_\_\_\_\_

Performed by company: \_\_\_\_\_

Name, address of specialist: \_\_\_\_\_

- Result of inspection:
- Continued operation questionable, reinspection required
  - Continued operation possible, remove defects by \_\_\_\_\_
  - No deficiencies, continue to operate

\_\_\_\_\_  
*Signature of specialist*

\_\_\_\_\_  
*Operating company signature*

If requested to take care of deficiencies

Deficiency removed on: \_\_\_\_\_  
*Operating company signature*

*(use a new form for reinspection!)*



## 16 Electrical circuit diagram

Object: JUMBO NT  
System:  
Customer:  
Circuit diagram number: JUMBO NT 03/14/001

### Grounding according to local regulations

Before commissioning check whether the nominal motor current matches the motor protection relay. Check all terminal points for proper connection and that all contact screws are tight.

Before commissioning, check all wiring and controls for proper function. Do not permit commissioning from the unauthorized side.

These plans were generated on a CAD system. To keep plans to the current state, we ask that you request Nußbaum to make the changes.

These circuit diagrams are intellectual property. They may not be given to third parties or reproduced without our permission!

Rights to make changes are retained.

### Circuit diagram and switch documents

Circuit diagrams were made to the best of our knowledge.

No warranty for the correctness of provided circuit diagrams and switch documents is given. This is particularly relevant for switches that were completed by us according to third party plans. This was done by us from purchaser provided manufacturer documentation.

### Functional test of switch systems

Circuit diagrams are not standard documents. When checking the control cabinet at the factory, field devices such as sensors, thermostats and motors cannot be included. For this reason, even with careful inspection, functional and switch errors cannot always be prevented.

Deficiencies are removed within the scope of guarantee during commissioning. During commissioning, if our services are not used, then no deficiency liability is accepted. Rework, including informing of circuit diagrams of switch systems not commissioned by us are therefore only done to an invoice according to our service terms and conditions. Costs for rework by third parties cannot be honored.

### Safety inspection and safety measures

The control cabinet has been produced, set up and inspected according to recognized technology rules according to VDE0100/0113 and accident prevention regulation VBG4 (electrical systems and equipment)

The following tests were done:

- Voltage test and/or insulation test of the control cabinet according to VDE0100/5.73
- Inspection of effectiveness of the safety measures used for indirect contact according to VDE0100g/7.75 para. 22
- Functional test and part test according to VDE560/11.87

Implemented safety measures:

- Protection against direct contact according to VDE0100/5.73. para. 4
- Protection against indirect contact according to VDE0100/5.73. para. 5

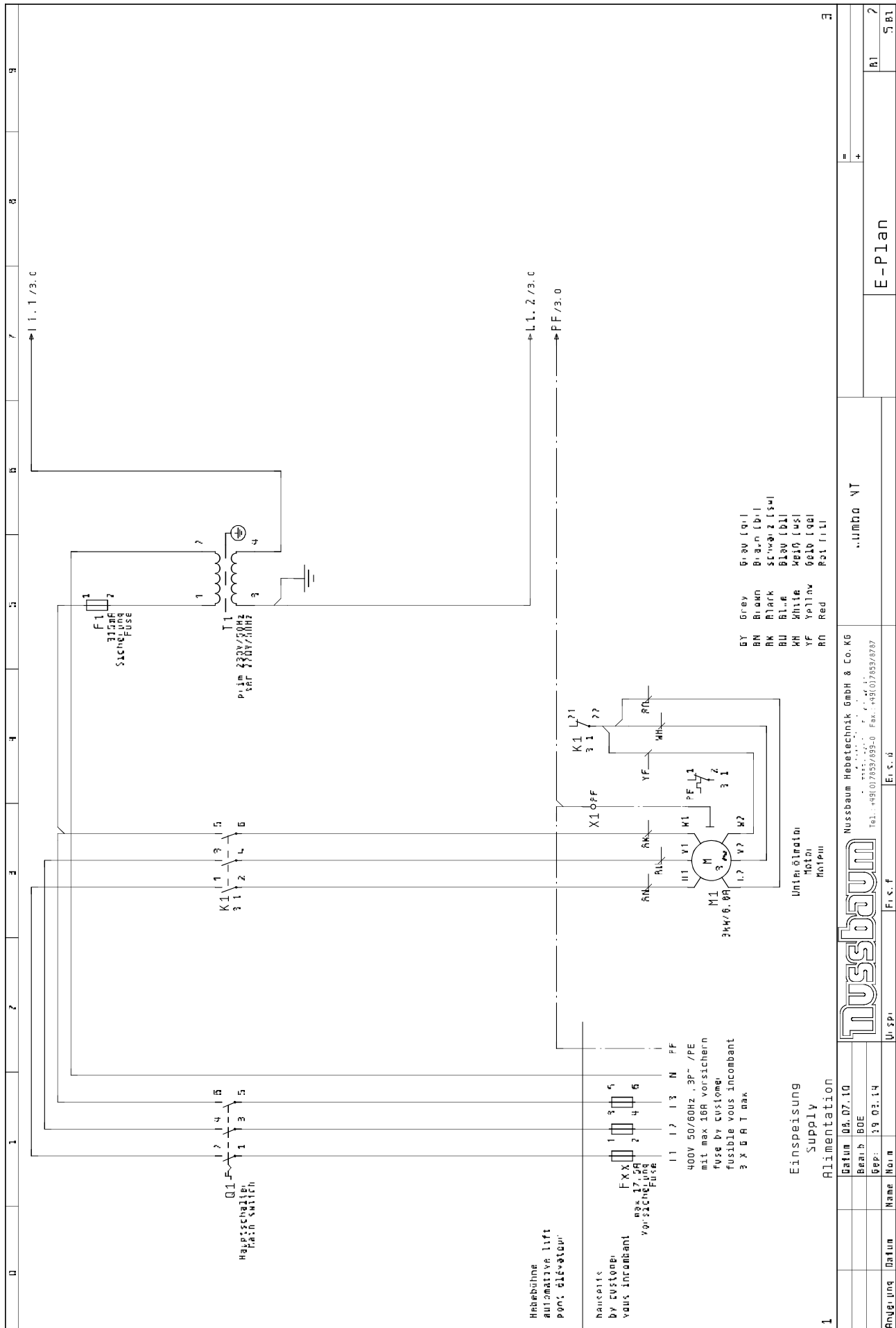

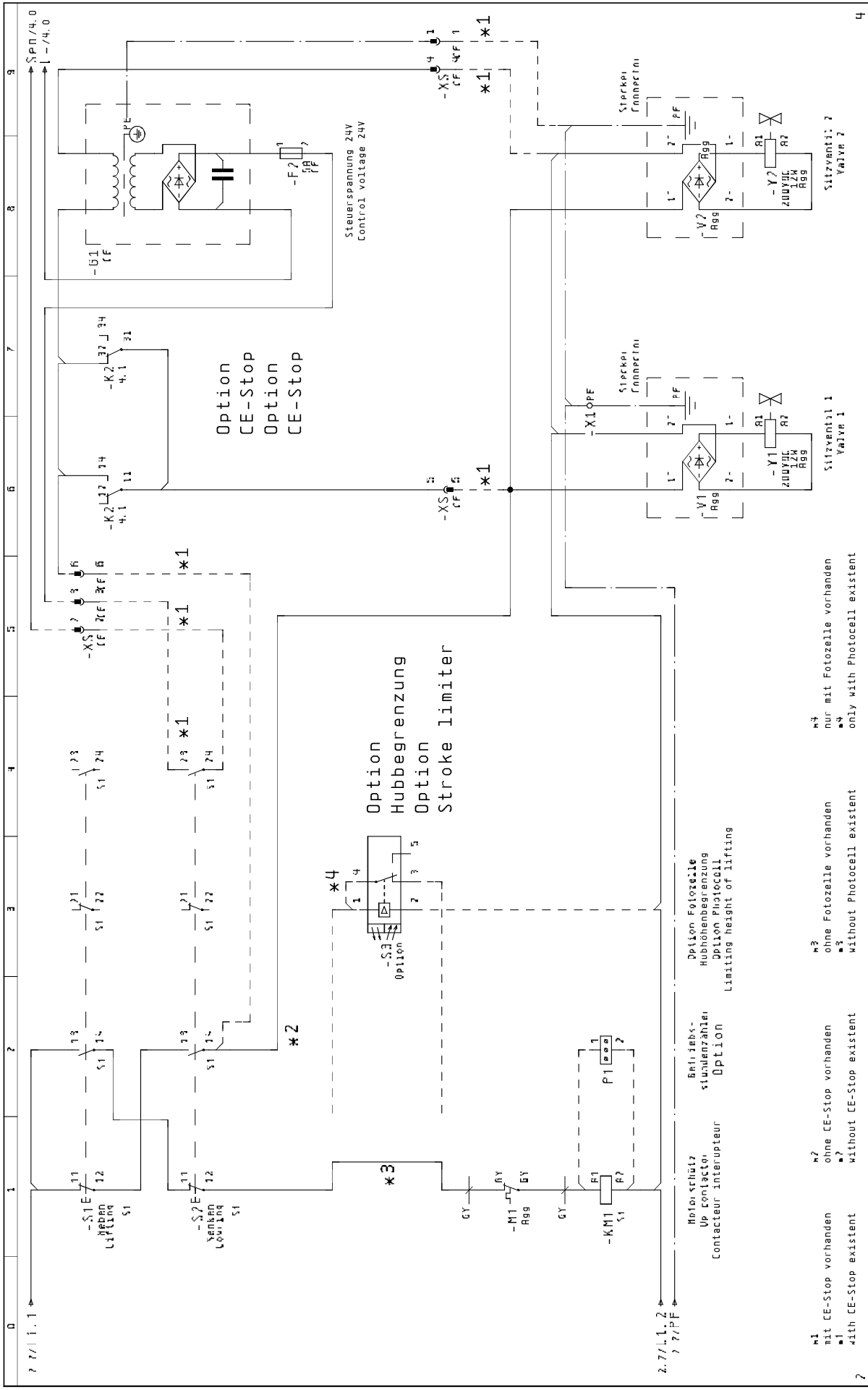

<p>Option Fotozelle Hubhöhenbegrenzung Option Photozell Limiting height of lifting</p> <p>Option Hubbegrenzung Option Stroke limiter</p> <p>Option Fotozelle Hubhöhenbegrenzung Option Photozell Limiting height of lifting</p>	<p>mit CE-Stop vorhanden with CE-Stop existent</p> <p>ohne CE-Stop vorhanden without CE-Stop existent</p> <p>mit Fotozelle vorhanden only with Photozell existent</p> <p>ohne Fotozelle vorhanden only with Photozell existent</p>	<p>Hubschlüssel Up contactor</p> <p>Senkschlüssel Down contactor</p> <p>Hubbegrenzung Limiting height of lifting</p> <p>Stromzähler Option</p> <p>Hubbegrenzung Limiting height of lifting</p> <p>Option Fotozelle Hubhöhenbegrenzung Option Photozell Limiting height of lifting</p> <p>Option Hubbegrenzung Option Stroke limiter</p> <p>Option Fotozelle Hubhöhenbegrenzung Option Photozell Limiting height of lifting</p>	<p>Steuerspannung 24V Control voltage 24V</p> <p>Sitzventil 1 Valve 1</p> <p>Sitzventil 2 Valve 2</p>
<p>Datum 03.11.10 Berat BOE GPP 19.03.14</p>	<p>Name Main</p>	<p>Wp Sp</p>	<p>F.R.S. f</p>
<p>Nussbaum Hebeteknik GmbH &amp; Co. KG Tel.: +49(0)7853/899-0 Fax.: +49(0)7853/899-1</p>			<p>JUMBO NT</p>
<p>CE-Stop</p>			<p>S.BL</p>

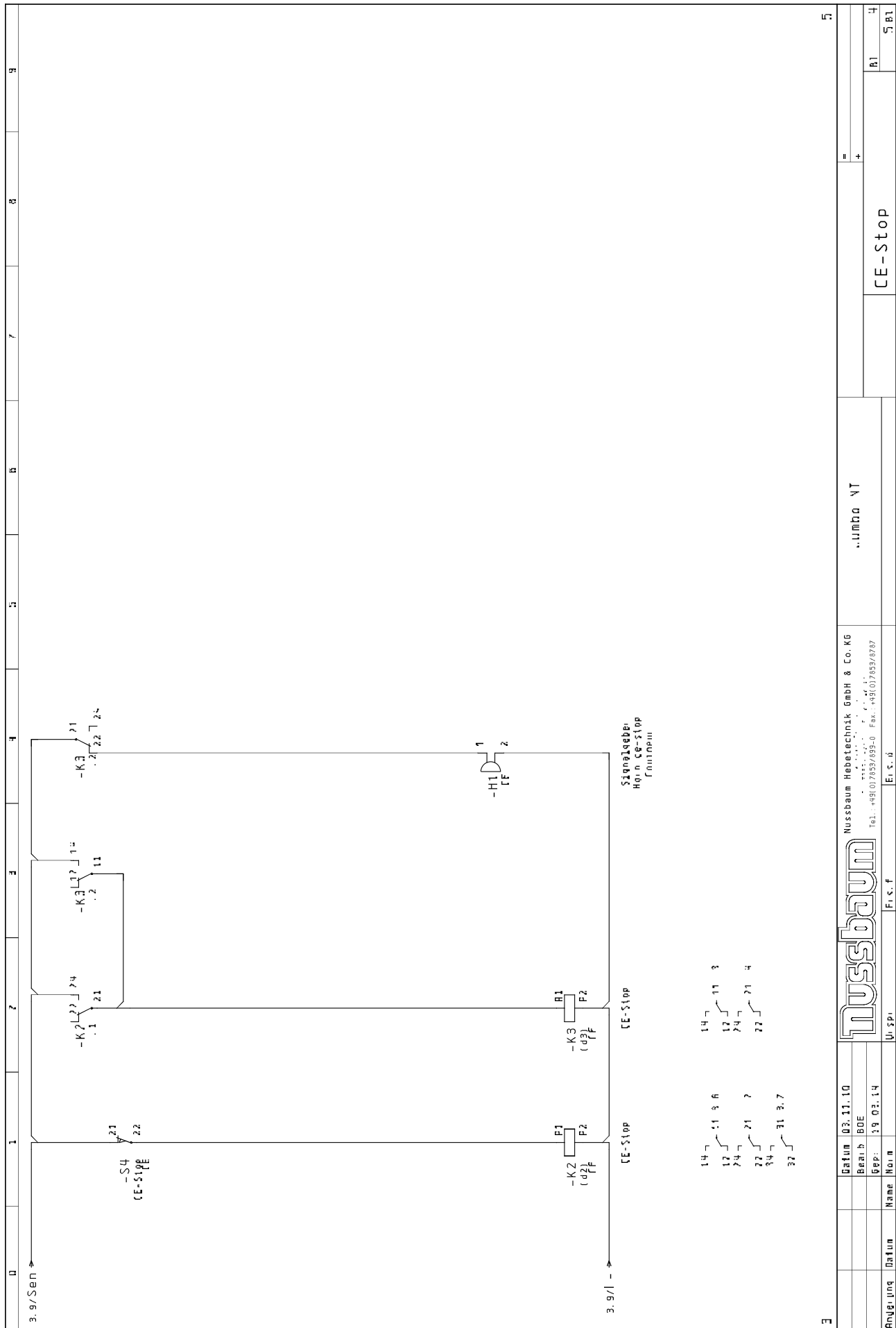



0	1	2	3	4	5	6	7	8	9
Stückliste Bill of materials Liste de matériel									
NUSTÜCK 17.01.2003									
Bauteilbenennung Component design Désign. component	Menge Amount Qté.	Bezeichnung Designation Description matériel	Typen number Model number Numéro de type	Lieferant Supplier Fournisseur	Artikelnummer Article number N° d'article				
-X1	1	Schutzleiterkl D 2,5/8. P. RD0 schn-schn	Q 2,5/8. P. RD0	Entlied	990183				
C1	1	Hauptsch. Not-Aus 3p. 16A 5. 5kW	R 10373. 0200-EV/50	Hau z GDBH	990403				
T1	1	Trenntransformator EI 66/34	TRAF0 1-PH	SCIMBIZZI	990059				
F1	1	Sicherungsklemme Trenner 5x20 mm	PH/8. SF	Fritlipler	990061				
X1	1	Schutzleiterkl DR 2,5/8. P. RD0 schn-schn	DR 2,5/8. P. RD0	Entlied	990079				
F1	1	Feinsicherung	FEINSICHERUNG	BIF	990913				
F1	1	Unterölmotor 3kW/ 6,8/11,8A 50HZ	U0742-371	Hannong GmbH	992658				
-Y1	1	Ventilstecker mit Brückenleichteichter	GERÄTESTECKER GLEICHRICHTER	Saehausen	991392				
-Y2	1	Ventilstecker mit Brückenleichteichter	GERÄTESTECKER GLEICHRICHTER	Saehausen	991392				
-Y1	1	Magnetventil 200V :DC 12V :100% E	MAGNETVENTIL	Saehausen	991393				
-Y2	1	Magnetventil 200V :DC 12V :100% E	MAGNETVENTIL	Saehausen	991393				
-S4	1	TI-U1 RD 90	GRENZFASTER 10 1S KLEIN STRABERLEISTUNG	BTR	990003				
-K2	1	INDUSTRIERELAIS 24V 4 Wechsler	2741	BTR	990267				
-F3	1	INDUSTRIERELAIS 24V 4 Wechsler	2741	BTR	990267				
-F2	1	Feinsicherung	FEINSICHERUNG	BIF	990307				
-X5	1	Steckergehäuse 6 polig ku	D5 0-100900-Q	AMP	990377				
-X5	1	Flachsteckhülse Stecker 6,3mm	D5447.123.111	AMP	990378				
-X5	1	Flachsteckhülse Buchse 6,3mm LUZN ohne ISU	D6032.123.111	AMP	990379				
-X5	1	Buchsengehäuse 6 polig ku	Z 305. J41R0732	AMP	990380				
-H1	1	Digitson akustischer Signalgeber	B/P 278	Deitron Components	990331				
-K2	1	Industrierelaissockel für 4 Wechsler	110178	BTR	990381				
-K3	1	Industrierelaissockel für 4 Wechsler	110178	BTR	990381				
-F2	1	Sicherungsklemme Trenner 5x20 mm	PH/8. SF	Fritlipler	990661				
-B1	1	Trafo + Gleichrichter + Kondensator	TRAF0 1-PH	SCIMBIZZI	990835				
-S3	1	Reflexions-Lichtschranke WL280-S230	REFLEXIONS-LICHTSCHRANKE WL280-S230	REFLEXION	992799				
-S1	1	PVC-KAPPE für Schalter Marquard	203 701 011	Hau quard: 31 GmbH	990371				
-S2	1	PVC-KAPPE für Schalter Marquard	203 701 011	Hau quard: 31 GmbH	990371				
-S1	1	Drucklaste schwarz 25 20 Marquard	1003.0101	Hau quard: 31 GmbH	990334				
-S2	1	Drucklaste schwarz 25 20 Marquard	1003.0101	Hau quard: 31 GmbH	990334				
-FM1	1	Leistungsschutz 5,7 kV 230 V 50-60 Hz	1110171 01 A 230V AC	LIVATIN PIERFIC	990841				

4

Date: 08.11.10		Nussbaum Hebetchnik GmbH & Co. KG	
Berat: BOE		JUMBO NT	
Gep: 19.03.14		Tel.: +49(0)7852/899-0 Fax.: +49(0)7852/8927	
Name: Man II	F.R.S. f	Stückliste	
U.S.P.		R1	
		S.B1	

# 17 Konformitätserklärungen, Declaration of conformity, Déclarations de conformité, Dichiarazione di conformità

## 17.1 JUMBO LIFT 3200 NT

### EG- Konformitätserklärung



gemäß Maschinenrichtlinie Anhang II 1A

Declaration of Conformity according Machinery Directive 2006/42/EG ANNEX II 1A  
 Déclaration de conformité selon directive machines annexe II 1A  
 Declaración de conformidad según Directiva Maquinaria 2006/42/EG ANNEX II 1A  
 Dichiarazione di conformità in accordo alla direttiva 2006/42/EG ANNEX II 1A

Hiermit erklären wir, daß die Hebebühne, Modell:

JUMBO LIFT 3200 NT

Hereby we declare that the lift model:  
 Par la présente nous déclarons que le pont élévateur modèle:  
 Por la presente declara, que el elevador modelo:  
 Con la presente si dichiara che il sollevatore:

allen einschlägigen Bestimmungen der folgenden Richtlinien entspricht:

fulfils all the relevant provisions of the following Directives:  
 correspond aux normes suivantes:  
 cumple todas las disposiciones pertinentes de las Directivas siguientes:  
 adempie a tutte le richieste delle seguenti direttive:

Maschinenrichtlinie / Machinery Directive  
 EMV Richtlinie / EMC Directive

2006/42/EG  
 2004/108/EG

in Übereinstimmung mit den folgenden harmonisierten Normen gefertigt wurde

was manufactured in conformity with the harmonized norms  
 fabriqué en conformité selon les normes harmonisées en vigueur.  
 producido de acuerdo a las siguientes normas armonizadas.  
 è stato fabbricato in conformità con le norme armonizzate

Fahrzeug- Hebebühnen / Vehicle lifts

EN 1493: 2010

Beauftragter für die Technische Dokumentation  
 Authorised to compile the technical file

Otto Nußbaum GmbH & Co. KG

Seriennummer  
 Serial number

Seriennummer

Kehl- Bodersweier, 31.03.2015

  
 Dr. Martin Huck  
 Geschäftsführer Technik / COO

DoC-NUS\_JUMBO-3200-NT\_2015-03.docx



Otto Nußbaum GmbH & Co. KG · Korker Str. 24 · D-77694 Kehl-Bodersweier  
 Tel.: +49(0)7853/899-0 · Fax: +49(0)7853/8787 · www.nussbaum-group.de



## 17.2 HYMAX XX 3200 PH

# EG- Konformitätserklärung



gemäß Maschinenrichtlinie Anhang II 1A

Declaration of Conformity according Machinery Directive 2006/42/EG ANNEX II 1A  
Déclaration de conformité selon directive machines annexe II 1A  
Declaración de conformidad según Directiva Maquinaria 2006/42/EG ANNEX II 1A  
Dichiarazione di conformità in accordo alla direttiva 2006/42/EG ANNEX II 1A

Hiermit erklären wir, daß die Hebebühne, Modell:

HYMAX XX 3200 PH

Hereby we declare that the lift model:  
Par la présente nous déclarons que le pont élévateur modèle:  
Por la presente declara, que el elevador modelo:  
Con la presente si dichiara che il sollevatore:

allen einschlägigen Bestimmungen der folgenden Richtlinien entspricht:

fulfils all the relevant provisions of the following Directives;  
correspond aux normes suivantes;  
cumple todas las disposiciones pertinentes de las Directivas siguientes;  
adempie a tutte le richieste delle seguenti direttive;

Maschinenrichtlinie / Machinery Directive  
EMV Richtlinie / EMC Directive

2006/42/EG  
2004/108/EG

in Übereinstimmung mit den folgenden harmonisierten Normen gefertigt wurde

was manufactured in conformity with the harmonized norms  
fabriqué en conformité selon les normes harmonisées en vigueur;  
producido de acuerdo a las siguientes normas armonizadas.  
è stato fabbricato in conformità con le norme armonizzate

Fahrzeug- Hebebühnen / Vehicle lifts

EN 1493: 2010

Beauftragter für die Technische Dokumentation  
Authorised to compile the technical file

Otto Nußbaum GmbH & Co. KG

Seriennummer  
Serial number

Seriennummer

Kehl- Bodersweier, 31.03.2015

  
Dr. Martin Huck  
Geschäftsführer Technik / COO









Händleradresse/Telefon:  
Dealer address / phone:  
Adresse de revendeur / téléphone :  
Dirección/teléfono del distribuidor:  
Indirizzo rivenditore / telefono:

15-02

**Nussbaum**

Otto Nußbaum GmbH & Co.KG • Kundendienst • Korker Str. 24 • D 77694 Kehl-Bodersweier  
[www.nussbaum-group.de](http://www.nussbaum-group.de) • e-Mail: [service@nussbaum-group.de](mailto:service@nussbaum-group.de)

Service Hotline Germany: 0800 5 288 911

Service Hotline International: +49 180 5 288 911