

Molnar Engineering Pty. Ltd

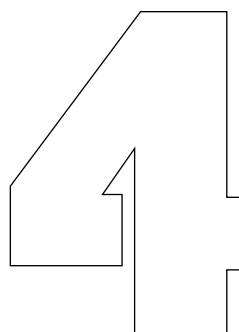

***Installation
Operation
Maintenance
Instructions
MOLNAR
Four Post
Hoist Models:
3585 & 4488***



OPTIONAL 240 VOLT SINGLE PHASE

MINIMUM REQUIREMENTS FOR ELECTRICAL CONNECTION OF MOLNAR HOISTS

Important: All installations should be carried out by suitably qualified persons. Failure to comply may void warranty.

The following information is a guide only based on the latest standards as set out in AS/NZS 3000, for installations outside of Australia & New Zealand refer to local standards/regulations.

Circuit Breakers should be of "D" curve type (motor start, high inrush current) - Ratings given as a maximum for circuit & motor protection based on DOL selection guide.

Voltage operating range: -6% to +10% of motor nameplate Voltage.

Motor Voltage 240V Operation range 225V to 264V.

Cable sizes are given as a guide only for a maximum cable length to 30m. Longest cable runs and in area where supply voltage is below motor voltage, calculation should be made to ensure Voltage Drop will not fall below minimum operating voltage.

When installed motors must be tested under Full Load checking Voltage at motor terminals.

Motor 2.2kW 240V Single phase model CWC3640F

Full Load Current	12.4 Amps
Min Cable Size	2.5mm 2 core + earth
Circuit Breaker	1 phase 32 Amp 10kA Recommended Clipsal 4CB132/10 or equivalent

No person should be permitted to operate the MOLNAR FOUR-POST HOIST without first studying the operating instructions on page 5 and safety precautions on page 4.

This manual should be kept in a safe place and referred to as necessary.

The installation requirements on page 24 must be completed and the certificate on the inside back cover must be signed by the installer. The guarantee card must be completed and returned to MOLNAR ENGINEERING PTY. LTD.

In tropical and steam cleaning conditions to prevent rust in the cylinder raise the hoist to full height and leave it there when not in use overnight and on weekends.

This vehicle hoist is not designed to be used for steam cleaning nor to be installed in the open exposed to the elements. Vehicle hoists installed under such conditions are not covered by our guarantee.

OPTIONS

MOLNAR JB 87

Molnar Jacking Beam

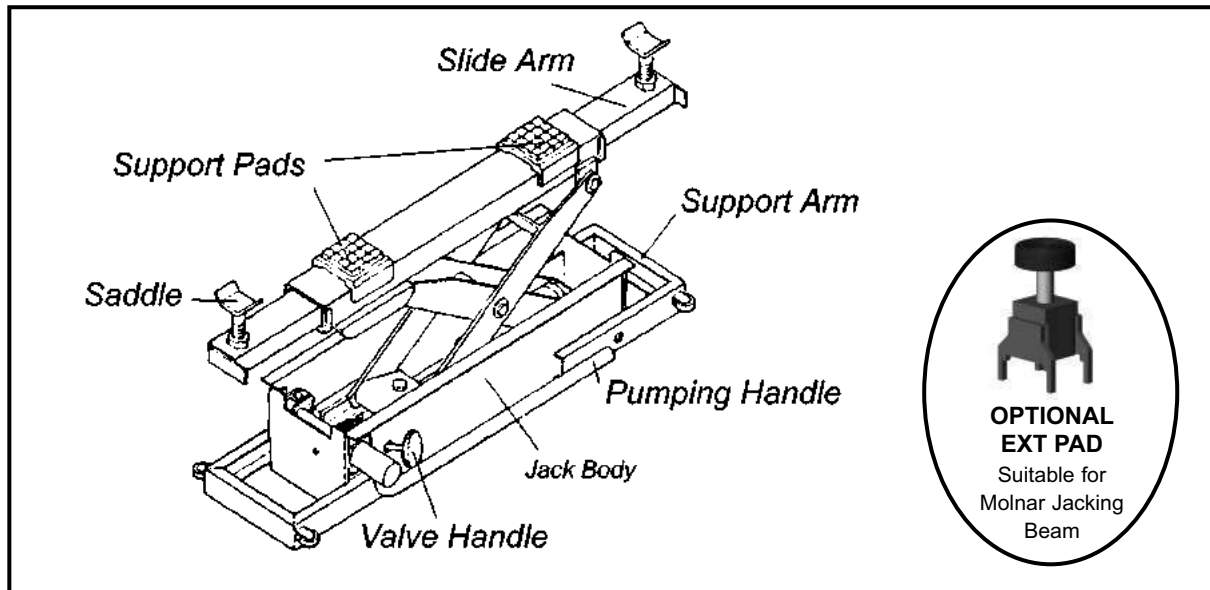

SPECIFICATIONS

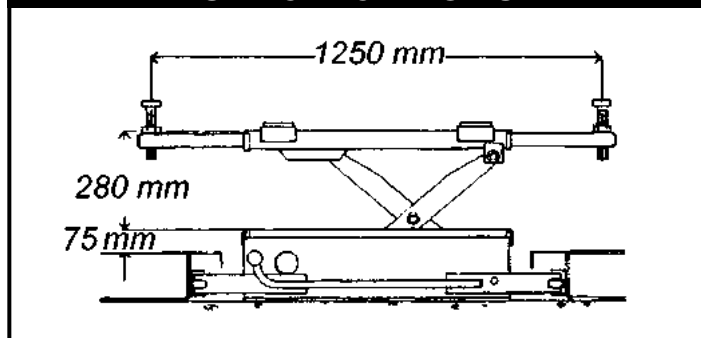

Specifications	
Capacity	2000 kg
Minimum Height	75 mm
Lifting Travel	280 mm
Maximum saddle spacing	1250 mm
Net Weight	78 kg
Fittings	2 Support Pads 2 Saddles

As industry leaders in the manufacture of 2 and 4 post vehicle hoists, Molnar Engineering Pty Ltd have applied this same knowledge to the JB 87 Hydraulic Jacking Beam.

The unit is for use in conjunction with a ramp 4 post hoist and has been specially designed to provide versatility and ease-of-operation for a wheel free system.

FEATURES

- Low profile in the parked position.
- Vertical travel of pumping handle provides for ease of vehicle lifting.
- Support pads and adjustable slide arms and saddles provide for all types of vehicles and lifting operations.
- Body end rollers allow for non-jamming travel along ramps.
- Large knurled handle permits easy gripping for valve control.

CONTENTS

	Page No.
Options	2
Foreward	4
Safety Precautions	4
Operating Instructions	5
Setting up the hoist	6
Floor Requirements	7
Installation	8 - 20
Parts Identification	12 - 13
Layout of wire ropes	18
Wiring Diagrams	19
General layout of locking mechanism	20
Betabite Hydraulics Assembly Instructions	20
Replacement parts list	21
Fault Chart	21
Maintenance	22
Drip Tray Inspection and Safety Instructions	23
Wheels Free Rails	24
Installation Requirements	24
Certification	25

FOREWORD

Molnar hoists are manufactured from only the best quality materials, and embody workmanship of the highest standards.

For continuous and satisfactory operation and prolonged life of the hoist, it is essential to follow all instructions in detail.

The part numbers in these instructions are intended only for explaining the installation of the hoist. For ordering parts, please consult the part numbers in the parts lists at the back of this book.

In the interest of technical progress, all specifications and instructions are subject to change without notice.

SAFETY PRECAUTIONS

It is important that the operating and safety instructions contained in this manual are read and fully understood before using the hoist.

Never exceed the Safe Working Load (SWL). The contents or load in any vehicle must be added to the vehicle weight, and the total must not exceed the SWL.

Before operating the hoist, ensure that any obstructions are removed from the vicinity of the hoist. Ensure that any personnel near the hoist are well clear and are aware that the hoist is about to be operated.

Personnel must not ride on the hoist and must not stand under the hoist until it has been locked into position.

Always position the vehicle so that the weight is evenly balanced on the hoist.

Take extra care when running a vehicle's engine while it is on the hoist. Ensure that the wheels are chocked and the handbrake is effectively engaged.

If the hoist is damaged in any way, it must be inspected by a factory authorised service agent to ascertain safe operation. If in doubt, do not operate the hoist until it has been inspected by a service technician.

Service the hoist in accordance with the instructions set out in the maintenance section of this manual.

SERVICE AND MAINTENANCE OF THE HOIST IS THE
RESPONSIBILITY OF THE OWNER

OPERATING INSTRUCTIONS

This product is designed to raise vehicles only for the purpose of examination, repair and maintenance whilst in raised position. Ref. AS1418.9

AUTHORISED OPERATORS

Only authorised persons who have read and understood the safety precautions and operating instructions may operate this hoist.

LOADING OF VEHICLES

Loading and unloading of vehicles must only take place with the platform fully lowered.

TO RAISE PLATFORM

- 1.) Ensure that the vehicle is correctly positioned so that it will be in a stable condition when raised.
- 2.) Position manual wheel chocks.
- 3.) Ensure that the vehicle hoist area is clear of all personnel and obstructions.
- 4.) **Raise function:** Depress RAISE BUTTON until desired height is reached. ENGAGE platform locking lever to ON position. Lower vehicle hoist by moving lowering lever downwards till pawls have engaged on all posts.

TO LOWER PLATFORM

- 1.) Ensure that the vehicle stability has not been affected.
- 2.) Ensure that the vehicle hoist area is clear of all personnel and obstructions.
- 3.) **Lowering function:** Raise the platform approx. 20mm by depressing RAISE BUTTON. DISENGAGE the platform locking lever to the OFF position. Lower vehicle hoist by moving lowering lever downwards.
- 4.) Remove manual wheel chocks.

WORKING ENVIRONMENT

This vehicle hoist is not designed to be used for steam cleaning nor to be installed in the open exposed to the elements. Vehicle hoists installed under such conditions are not covered by our guarantee.

HYDRAULIC OIL

Castrol hyspin AWH46, Shell Tellus T46, Mobil DTE 25, BP Bartran HV46 or equivalent.

REGULAR MAINTENANCE

This vehicle hoist should be periodically inspected and serviced as described in the operating manual. If any part of the vehicle hoist is accidentally damaged it should be thoroughly inspected to ascertain serviceability. If in any doubt take the vehicle hoist out of service pending inspection by a Molnar Engineering Pty. Ltd. authorised service agent.

SETTING UP THE CAR HOIST

- The drive-on end is normally post No. 1 and No. 2. Drive-through operation can be ordered if required.
- Operation is always from post No. 1.
- The power pack with electric motor is always mounted on Post No. 1.

FIGURE 1

MODELS: 3585 & 4488

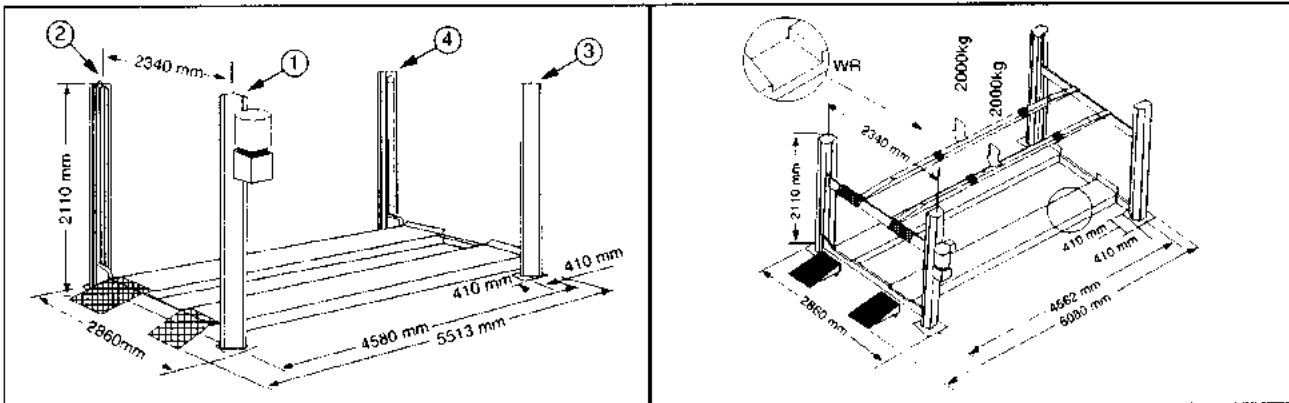

MODEL: 4488 D

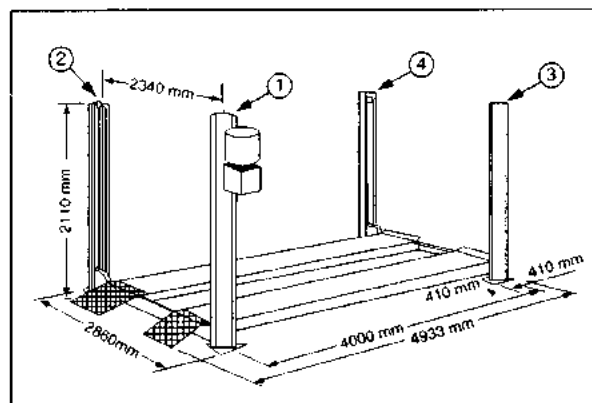

EXTRA WIDE "A" SERIES for 3585 & 4488.

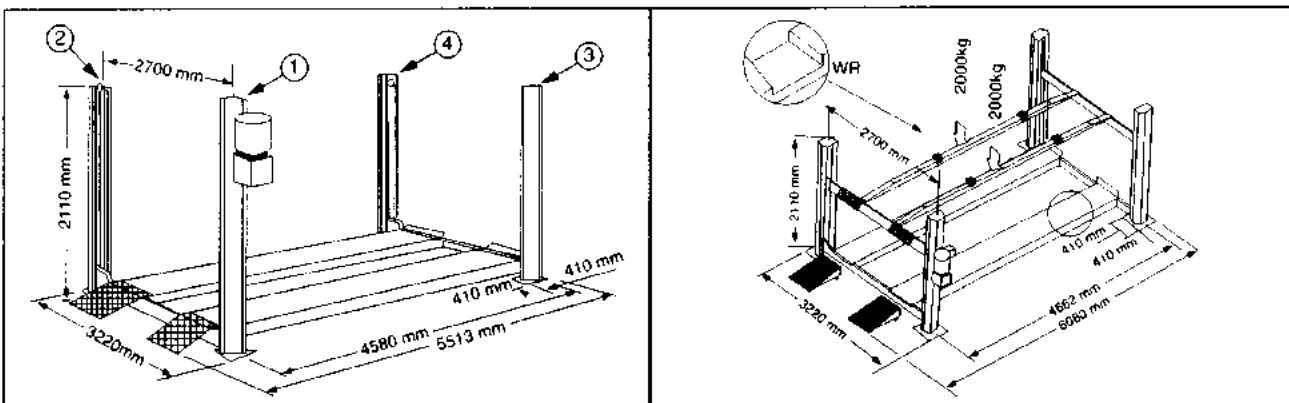

The Manufacturer reserves the right to alter these features and specifications without notice.

FLOOR REQUIREMENTS

The floor should be a reinforced concrete slab with Compressive strength of minimum 25Mpa.

Reinforcement wire diameter 6mm x 200mm x 200mm square mesh F42 grade.

Minimum thickness of 100mm.

For a successful installation, it is important that the floor is flat and level at the points where the posts are bolted to the floor.

Maximum level differences are referred to in Figure 4.

FIGURE 2

When the floor slope is greater than the recommended difference (Figure 4) the four post foundation plates must be levelled by either:

A LOCAL LEVELLING BY MEANS OF CONCRETE FOUNDATION BLOCKS

B BY SUITABLE PACKING UNDER POST FOUNDATION PLATES

Figure 4A shows the recommended concrete foundation blocks.

FIGURE 3

A drive-on angle that is too acute (as illustrated) is to be avoided, as this condition can cause damage to the underside of vehicles.

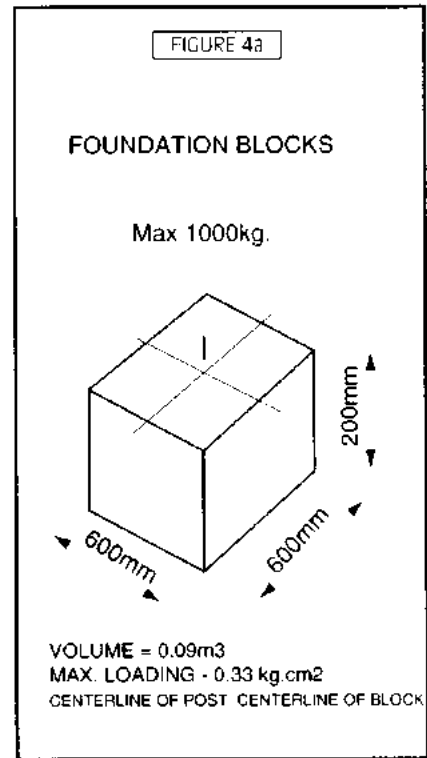
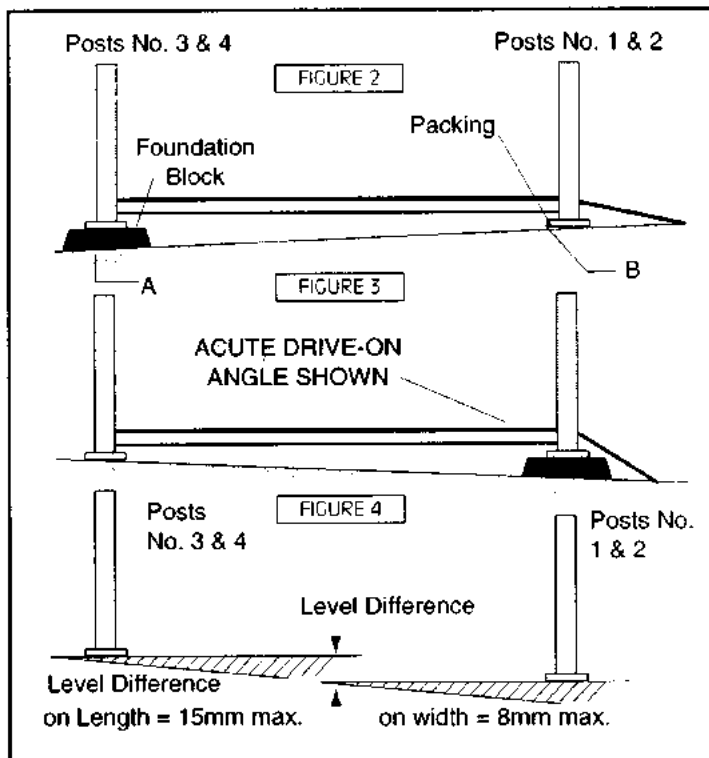

FIGURE 4.

The maximum difference permitted between the levels of the post foundation plates is as follows:

ON LENGTH
Maximum 15mm

ON WIDTH
Maximum 8mm

Although the above mentioned tolerances are permissible, it is essential to reduce level differences to the absolute minimum.

The installation, of a hoist to be used in conjunction with wheel aligning equipment, must be effected on an absolutely level and horizontal plane.

FIGURE 5

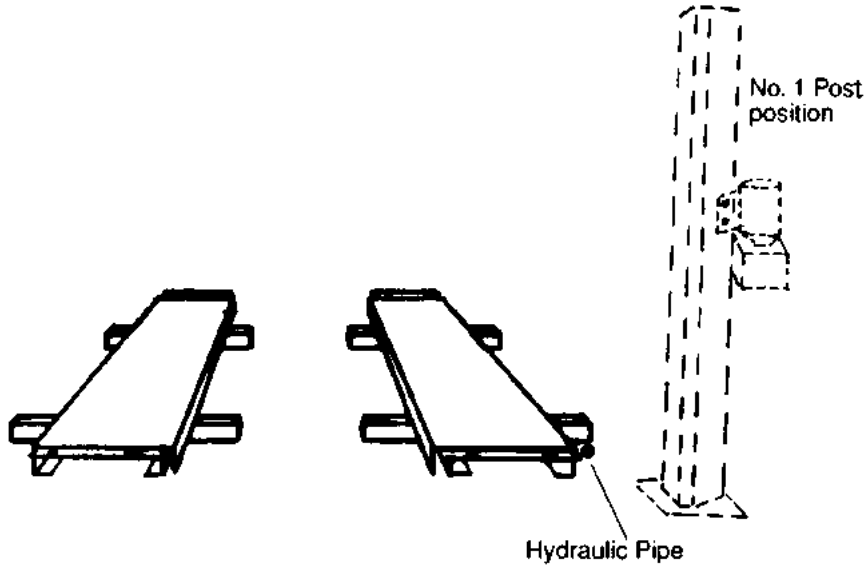

FIGURE 6

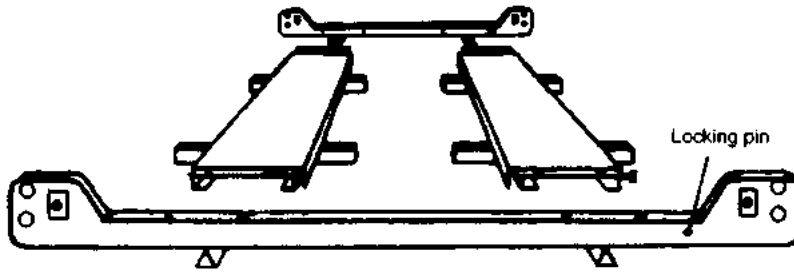

FIGURE 7

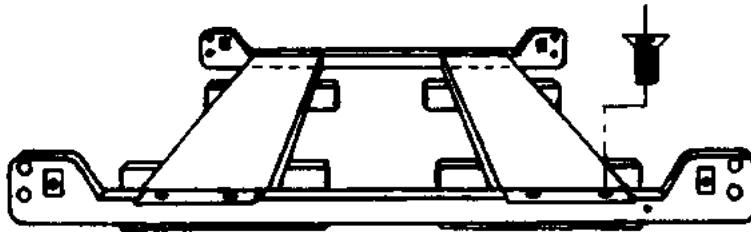
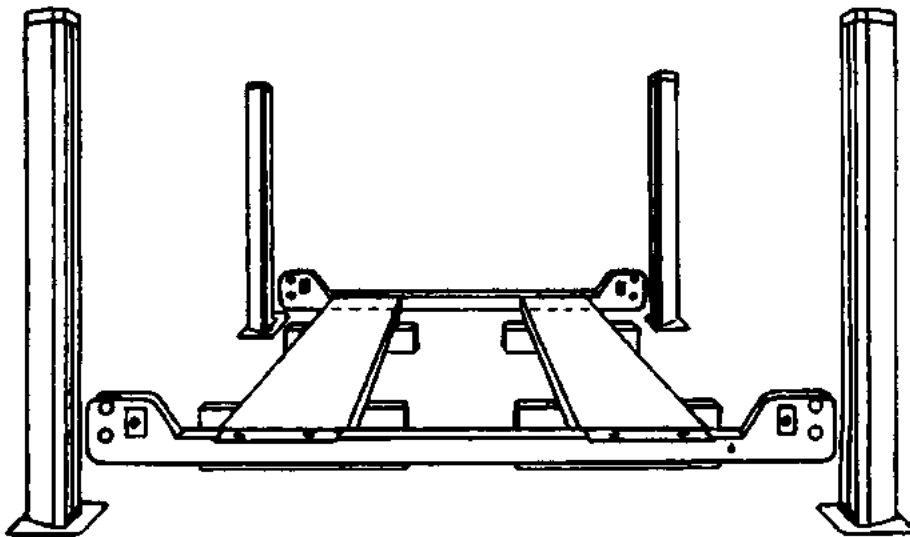
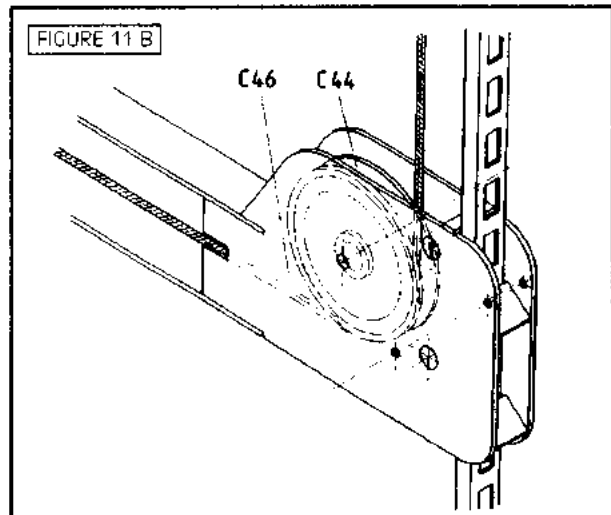
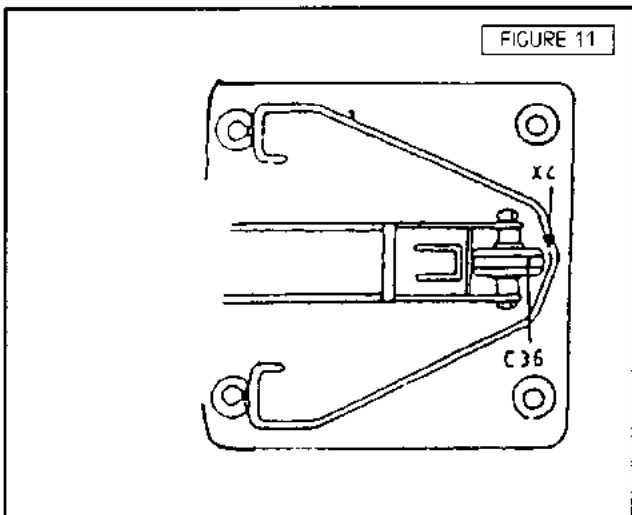
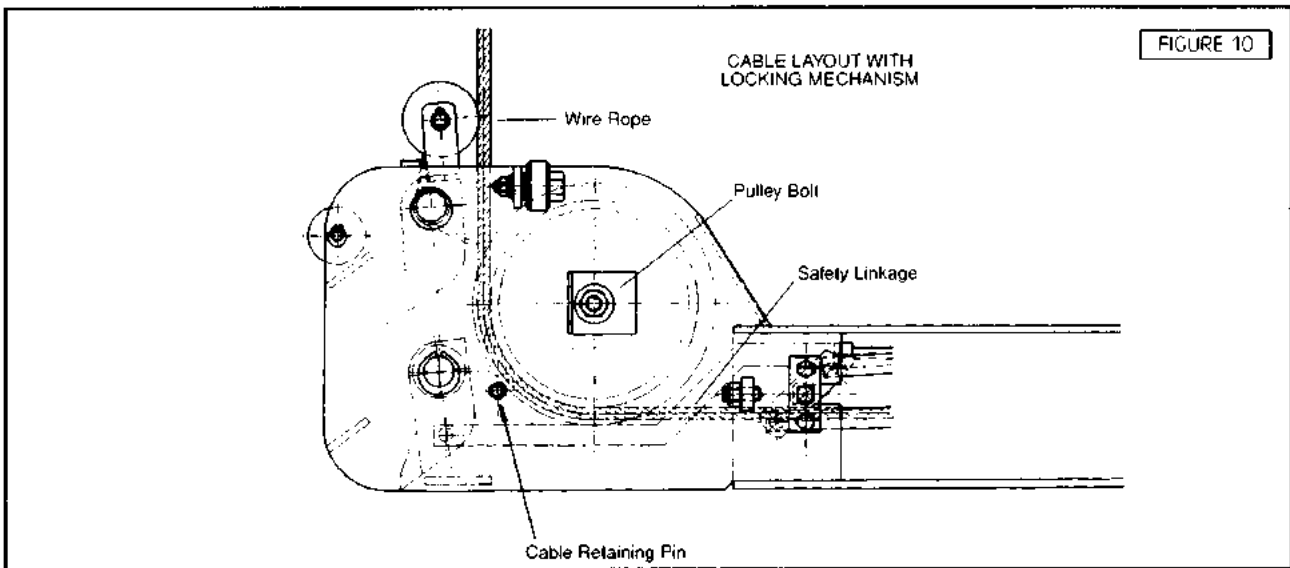
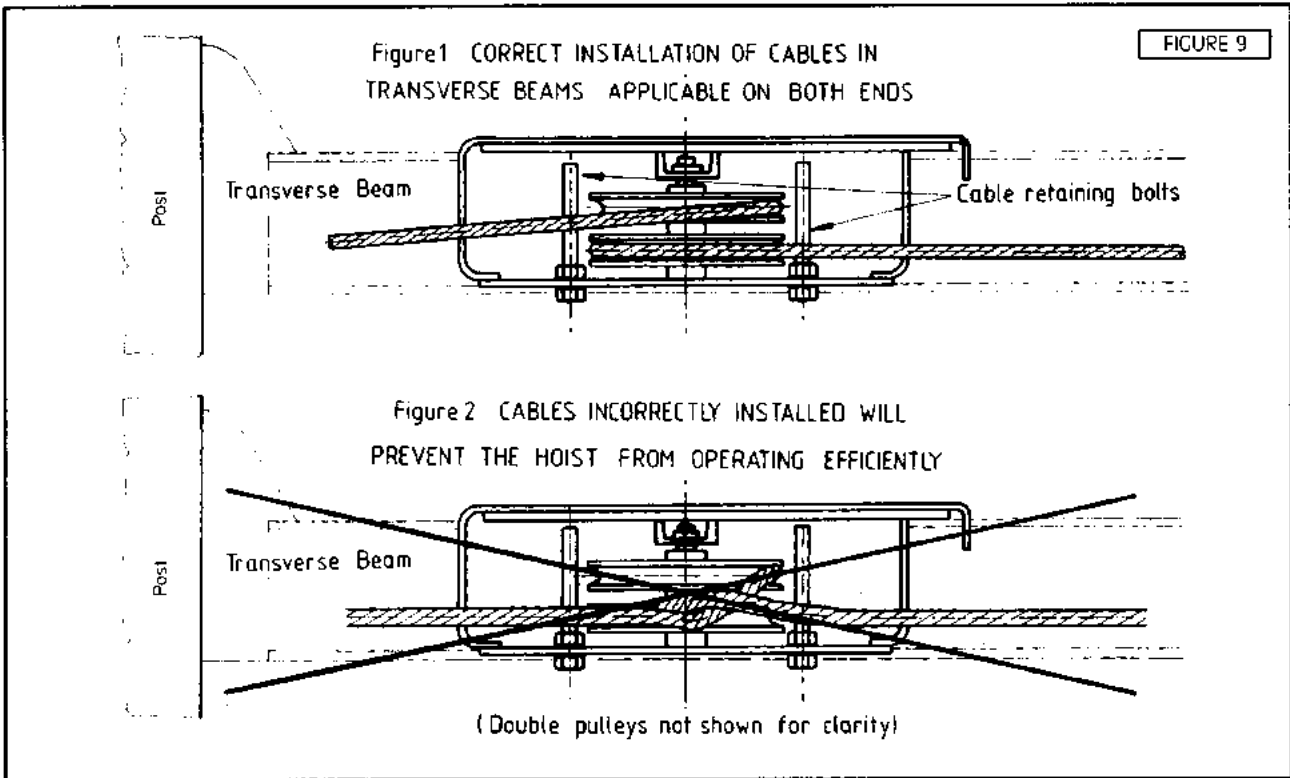

FIGURE 8



INSTALLATION OF THE HOIST

1. Determine the exact location where the hoist is to be installed and clear the area of all obstructions. The floor should be prepared in accordance with the section "FLOOR REQUIREMENTS" page 7. Place hoist in position with the hydraulic pipe to the 'drive-on' end of hoist.
2. Place the platforms into position on blocks approximately 150mm high. The platform with the hydraulic pipe is to be positioned adjacent to No. 1 Post (Motor Post). Refer to Figure 5.
3. Position the transverse beams on blocks approximately 100mm high, ensuring that the detent ball assembly is located adjacent to the No. 1 post position. The transverse beams should be slightly clear of the platforms, allowing access to the pulleys in the driver's side. Refer to Figure 6.
4. Cut the wires securing the wire ropes, taking care not to damage the wire ropes. Pull out the wire ropes,
Remove nuts from the cable ends for assembly purposes and install the wire ropes in the transverse beams in the following manner.
Remove the wire rope retaining pins from the ends of the transverse beams. Remove the bolts from the pulleys in the transverse beams. **Ensuring the wire ropes are not crossed [Figure 9]**, thread them through the transverse beam ends [Figure 10]. It is necessary to slide the pulley forward to allow room for the wire rope end to fit through. Replace the pulley bolts and wire rope retaining pins, ensuring that the wire ropes are properly located on the pulleys. Check that the pulleys have not fouled the toggle linkages.
- 4a** *The installer must check that all cables are correctly located on the pulleys, refer figure 19 and all cables are on the inside of the cable retaining pins.*
5. Move the transverse beams into position under the platforms.
NOTE- WHEEL-FREE models only: Move the transverse beams with the support brackets facing outwards into position under the platforms.
6. Lift transverse beams into position, making sure that the wire ropes do not foul any part of the toggle linkages.
7. Bolt the platforms to the transverse beams with the countersunk bolts, using a 6mm Allen key [Figure 7].
8. Make final adjustments in the position of the transverse beams and platforms, ensuring that they are as close to the final position of the hoist as possible. Ensure that the platforms are square to the transverse beams.
9. NOTE: "WHEEL - FREE" models only;
Place the additional transverse beams into position.
10. NOTE: "WHEEL - FREE" models only:
The control sides of the "Wheel - Free" beams are adjacent to No. 1 and No. 3 Posts, with the handles on the outside.
11. Place the posts in position, locating the No. 1 post [with motor mounting holes] near the hydraulic pipe in the driver's side platform. The ends of the transverse beams should be inside the posts, with the rollers at the ends of the beams contacting the backs of the posts [position x4, Figure 11].



INSTALLATION OF HOIST

12. Install the safety rails in the following manner: Tilt the top of the post out slightly, then feed the safety rail down through the transverse beam. The open side of the safety rail must face the opposing post. The rail slides between the guide roller and the bottom plate of the transverse beam. Replace the post back in the vertical position so that the safety rail rests inside the post (Figure 11A). NOTE: The four safety rails (eight in the wheel-free system) are identical and can be fitted in any post.
13. The safety rail is bolted to the top of the pillar in the hole closest to the back of the post using bolt supplied (Figure 12) and secured with nut and locknut. There must be a clearance of approximately 2mm between the safety rail and the inside top of the post, so that the rail can move freely.
NOTE: 4488 Models [4 Tonne] have a damping rubber on all platform safety rails around the bolt on top of the post (Figure 13).
NOTE: WHEEL - FREE SYSTEM: The safety rails for the wheel-free system outer transverse beams are installed in the same way as the inner transverse beams (but there are no damping rubbers used on the outer transverse beams Figure 14).
14. Fit the wire ropes to the tops of the posts using nuts supplied. Use only one nut per wire rope, and do not tension the wire ropes at this stage.
15. Fit the power pack to the No. 1 Post using the bolts and nuts provided (Figure 15).
Fit the limit switch mounting bracket and the limit switch to the No. 1 Post.
Fit the limit switch actuating bracket to the transverse beam (Figure 16).
16. Fit the flexible hydraulic hose to the pump assembly and to the pipe protruding from the platform. Ensure that all unions are tight.
(Refer to Figure 20 Betabite Hydraulics Assembly Instructions)
17. Fill the hydraulic tank (to oil level line) with the 5 litres of hydraulic oil supplied.
18. Connect the electrical wiring to the contact box.
NOTE: Depending on installation, and State regulations, a licensed electrician may be required to perform this task.

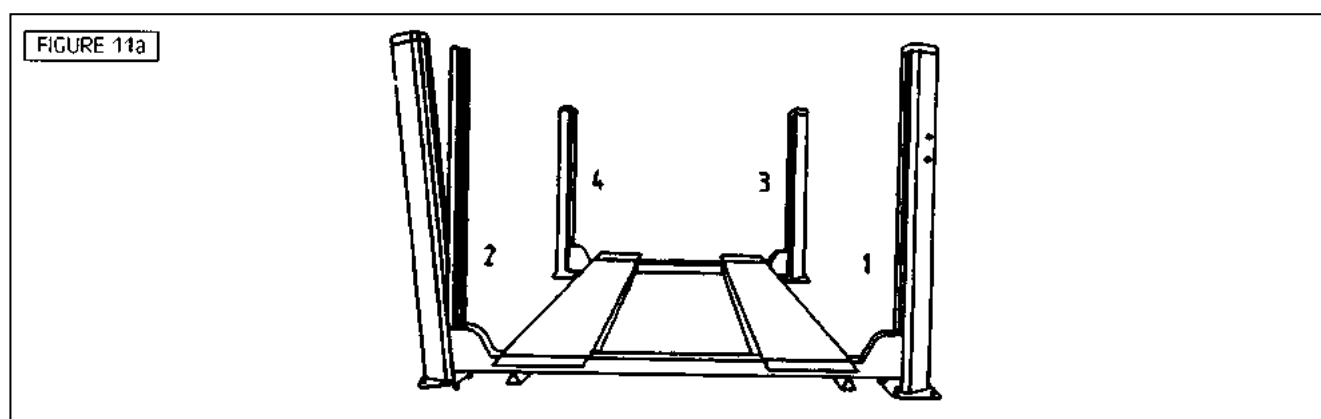

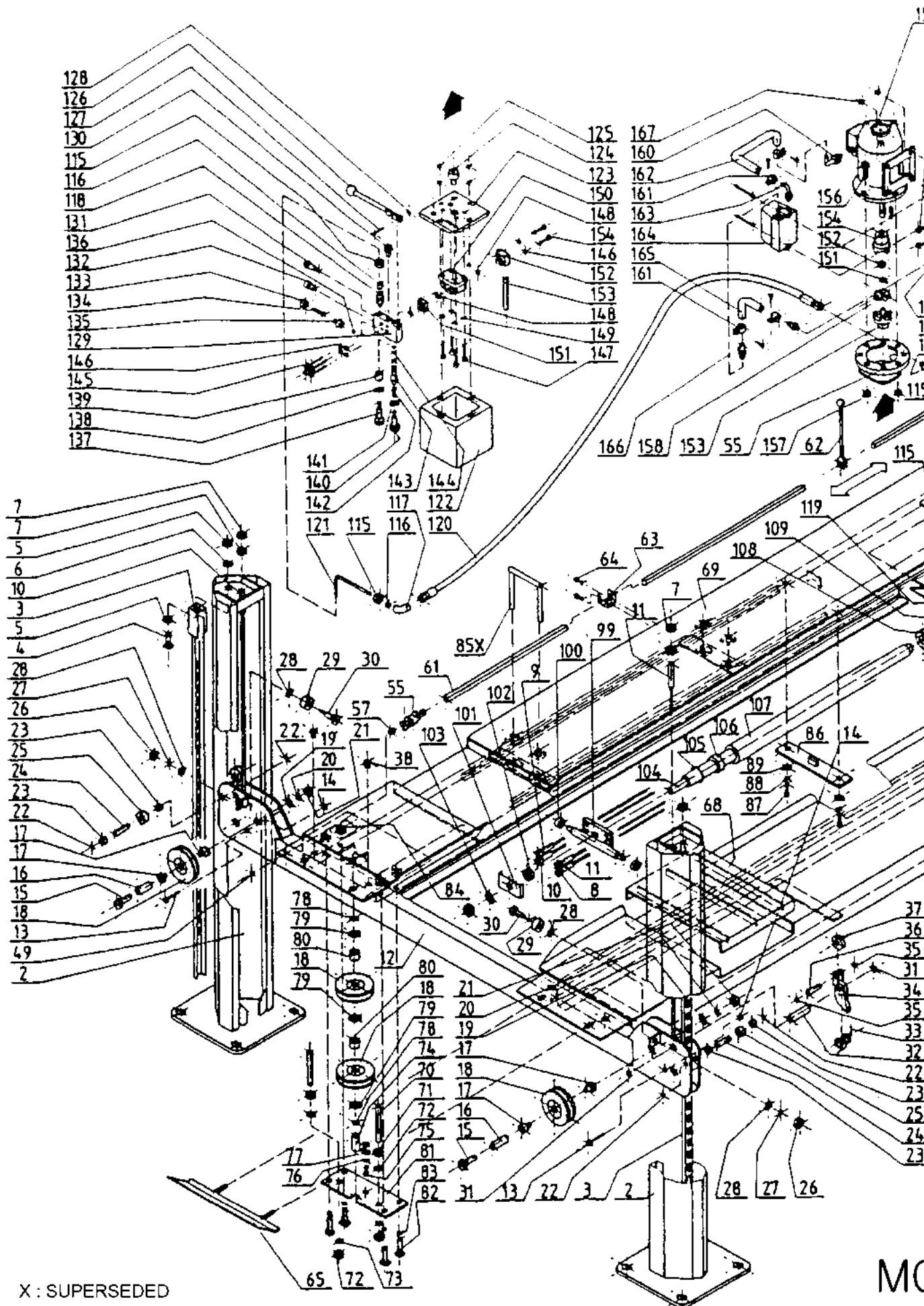

X : SUPERSEDED

MO

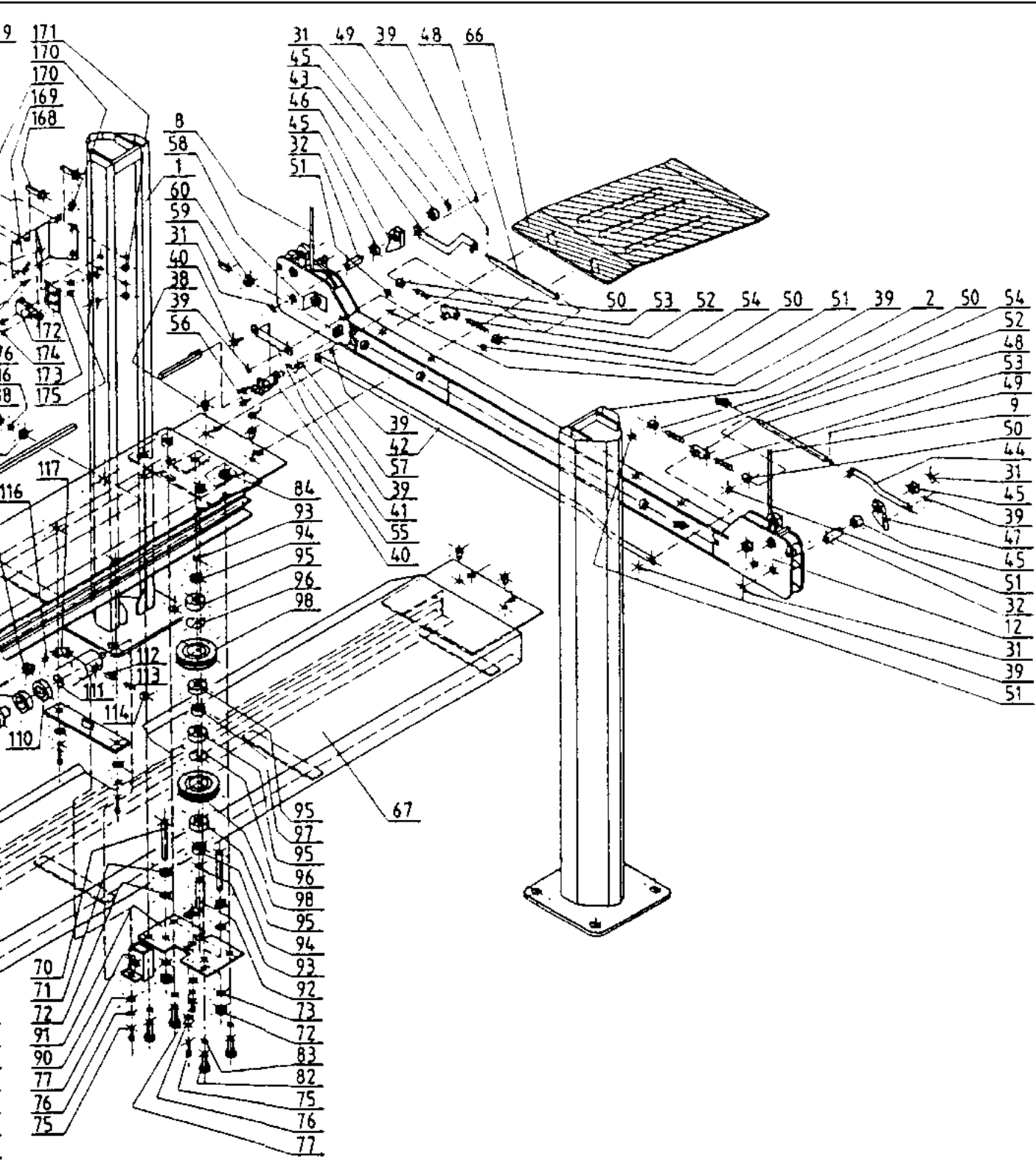

MODEL 3585 & 4488

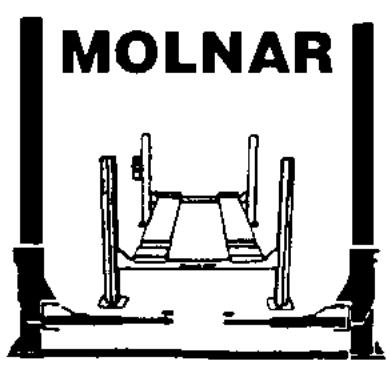

FIGURE 12

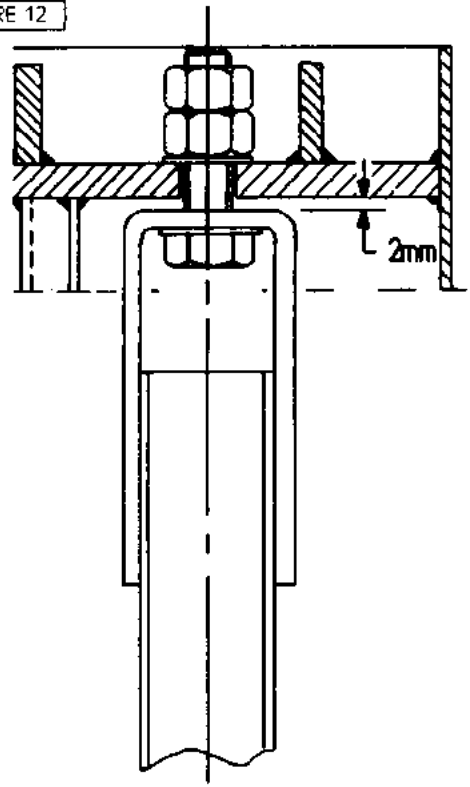

FIGURE 13

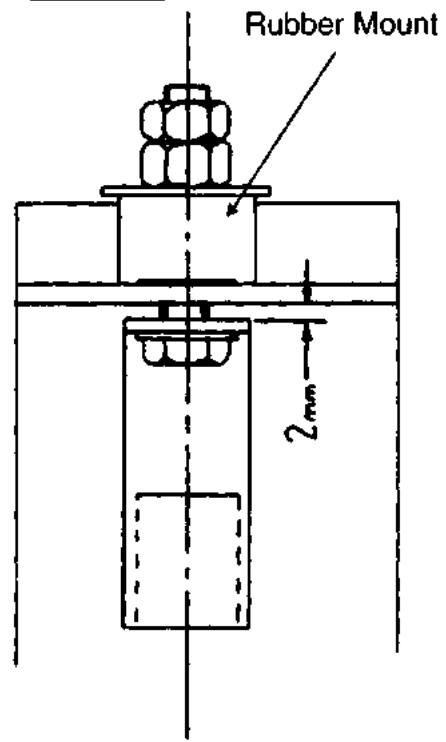
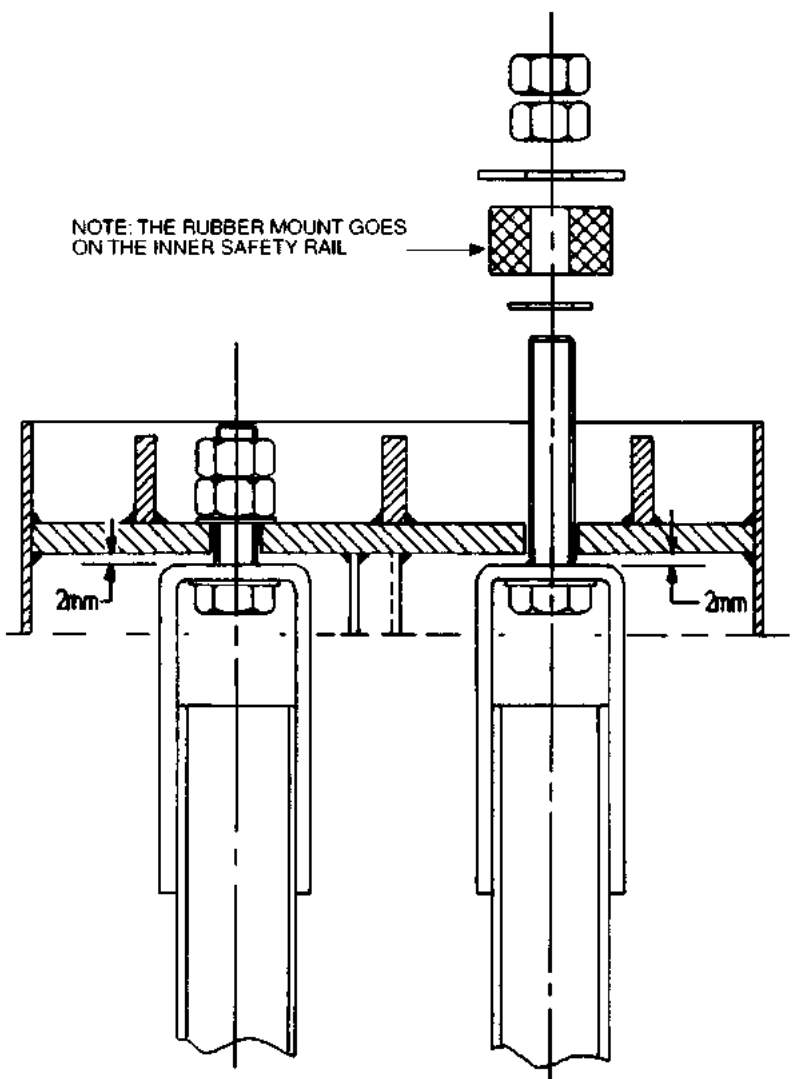

FIGURE 14



INSTALLATION OF HOIST

19. Press the starter button on the contact box and raise the hoist slightly. If the motor turns, but the hoist does not lift, then the motor is turning in reverse, and two phases in the contact box must be interchanged to reverse the direction of rotation (by an Electrician).
20. Raise hoist approximately 200mm and remove the blocks on which the transverse beams and platforms have been resting. Check all the hydraulic couplings to ensure there are no oil leaks (including hydraulic cylinder coupling).

NOTE: MAKE SURE THAT THE WIRE ROPES ARE NOT CROSSED AND THAT THEY DO NOT FOUL ANY PART OF THE HOIST ASSEMBLY OR THEIR LIFE WILL BE SEVERELY SHORTENED.

21. Lower the hoist to a point where the end of the transverse beam adjacent to No. 1 Post is approximately 50mm from the base plate.
22. Adjust the posts so that they are square to the transverse beams and the rollers at the ends of the beams contact the backs of the posts. Do not force the posts against the rollers.
23. For the hoist to function correctly, it is essential that the sides of both transverse beams are exactly vertical. Using a spirit level, check the transverse beams at the points indicated by the arrows in Figure 17. If the beams are out of vertical, shims (packing X11) between the platforms and transverse beams will have to be used as indicated in Figure 18.
24. When all posts are correctly positioned, secure them to the floor. 16mm x 64mm DYNABOLT are recommended for fastening down. This may differ in some states.
25. The posts must be exactly vertical in all planes and to each other for correct operation of the hoist. If they are not vertical, shims must be used under the baseplates.
26. Ensure that the locking toggles at the control ends of the transverse beams (adjacent No. 1 & No. 3 Posts) are both off. Fit the long square tube, (with the load holding control handle in a near vertical position) by sliding the control end over the safety-actuating square lug on the transverse beam adjacent to No. 1 Post. Bow the tube, by pulling out at the middle of the tube and slide the other end of the tube on the safety-actuating square lug on the transverse beam adjacent to No. 3 Post. Fit the retaining bracket to the centre of the driver's side platform.
27. Lower the hoist (using the lowering lever on the power unit) until the transverse beams rest in the centering plates at the bottom of the posts. Tension the wire ropes via the nuts in the following manner:

NOTE: In order to allow for normal wire rope stretch, it is advisable to have a car on the hoist for this operation.

Tension the 4 wire ropes until they are just about to lift the transverse beams. Engage the locking toggles by moving the load-holding control handle to the horizontal position. Raise the hoist, taking note of the clicking sound made by the locking toggles. If the four toggles all click together, the load holding is operating correctly. If the toggles are not synchronised, appropriate adjustments must be made. Leaving the load-holding control handle in the ON position, lower the hoist until all locking toggles are engaged, observing when the locking toggles engage in relation to No. 1 Post. Adjust the wire rope tension at one post at a time until all locking toggles engage simultaneously. The platforms should be level when all four locking toggles lock in simultaneously. When the locking toggles are operating satisfactorily, fit the lock-nuts to the wire rope ends and tighten.

FIGURE 15

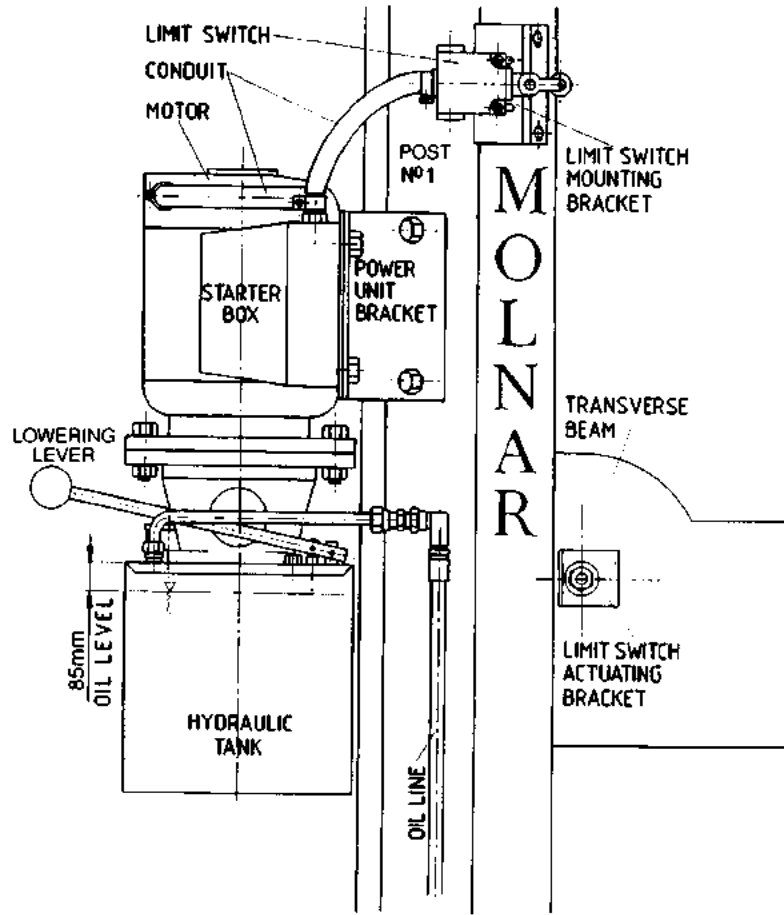
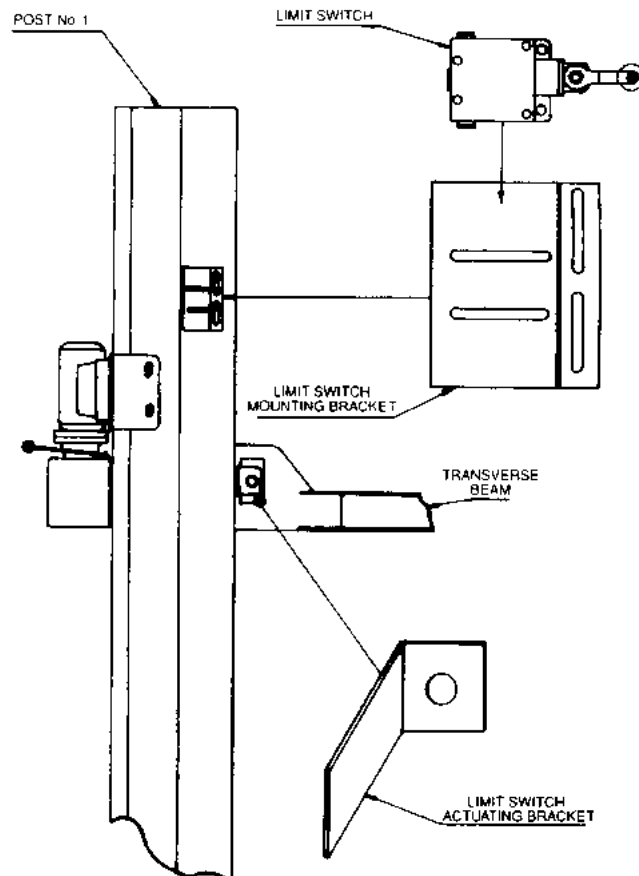

FIGURE 16



INSTALLATION OF HOIST

28. Adjust the side rollers on the transverse beams so that they just contact the sides of the posts.

NOTE: This is not applicable to the "WHEEL-FREE" models.

29. Adjust the limit switch actuating bracket so that it clears the No. 1 Post by approximately 2mm.

Adjust the limit switch so that the hoist automatically stops before the safety toggle rollers reach the wire rope ends.

30. Fit the run-up ramps at the drive-on end, and the wheel stops at the other end of the platforms.

NOTE: "WHEEL-FREE" models only. Bolt the run-up ramp locating bar in position and fit the other section of the run-up ramps. Fit the run-up ramp extensions. Fit the two WHEEL-FREE RAILS so that they rest on the secondary transverse beams.

31. Double check that all wire ropes are properly seated on the pulleys, (refer layout of wire ropes) and that the hoist is operating correctly.

Double check that the wire ropes are not crossing each other.

FITTING OF JACK STAND AND JACKING BEAMS JB87

32. Fit The Jack Stand (and Jacking Beams "JB87", (if purchased).

NOTE: Remove 3 of the 4 countersunk bolts holding the secondary platform (platform adjacent to NO. 2 and No. 4 posts) in position. Slide the platform outwards, place the Jack Stand (and Jacking beams) into position. Slide the platform into the original position.

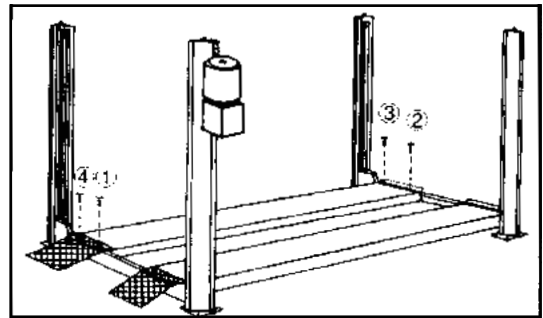

Re-bolt the platform with the 3 countersunk bolts.

33. Clean the hoist of anti-corrosion spray.

FITTING OF DRIP TRAY 44880DRPT

34.(1). Raise hoist to normal working height, engage safety locks and lower until hoist is just resting on the safety locks.

(2). Orientate Drip Tray so the Support Tabs are on the top and slide Drip Tray over the top of the Ramp Brace Strap. Refer to Figure 21 on page 23, steps 1, 2 & 3.

(3). Locate Drip Tray in the cavity created by the inside edges of the ramp, the Ramp Brace Strap and the Cylinder Support Strap. Refer to steps 4 & 5.

(4). Push down on the Support Tabs to ensure the bottom of the drip tray protrudes slightly below the bottom of the Straps. Refer to step 6. It is important that the top of the Drip Tray is pushed down as low as possible for there is little clearance from the top of the Straps and the bottom of the Cable Block. The Drip Tray is in danger of being crushed by the Cable Block if the top of the Drip Tray is too high.

(5). Check Drip Tray clearance by slowly lowering the hoist until Cable Block travels over the area of the Drip Tray. If the Cable Block touches the Drip Tray repeat step 4.

(6). Installation is complete.

FIGURE 17

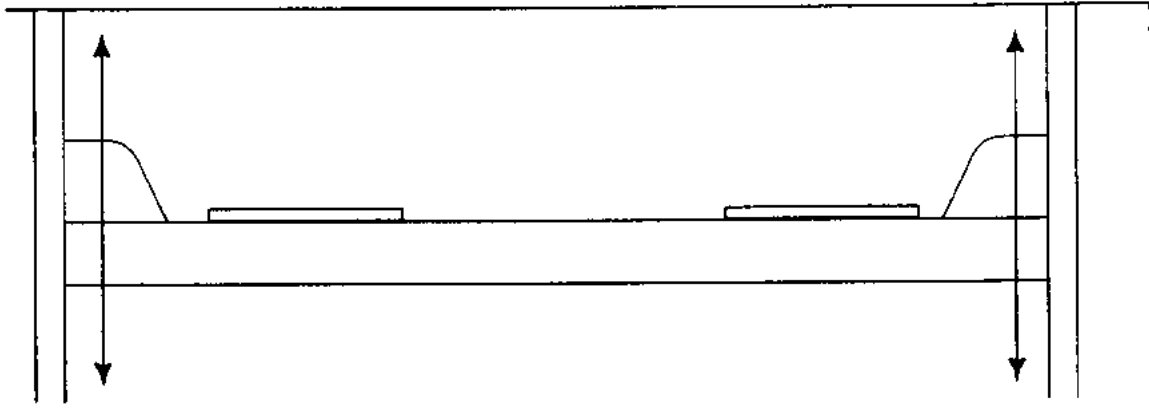
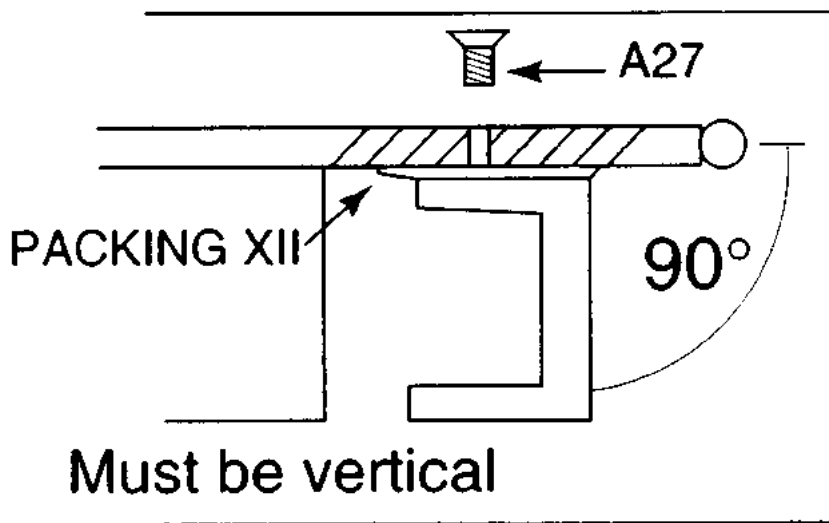
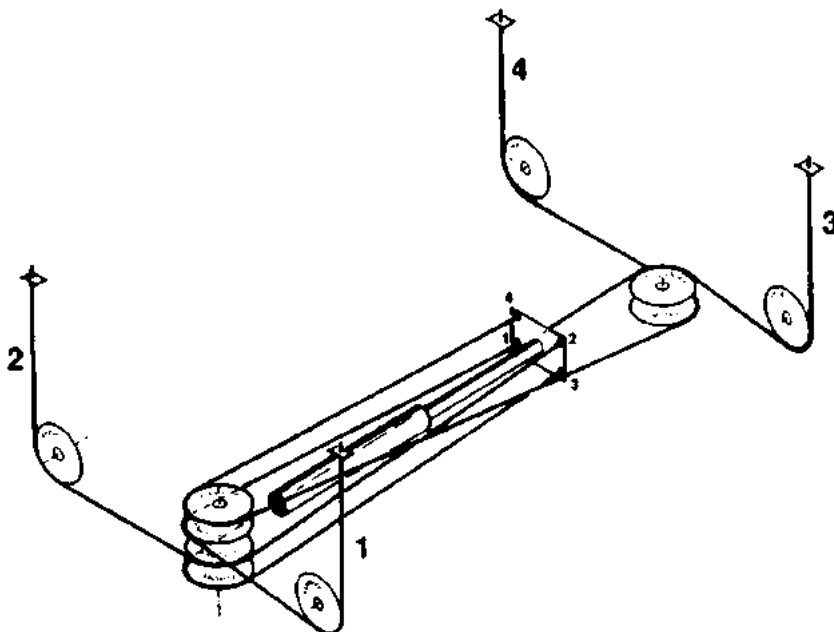

FIGURE 18



LAYOUT OF WIRE ROPES

FIGURE 19



WIRING DIAGRAMS

TO MOTOR

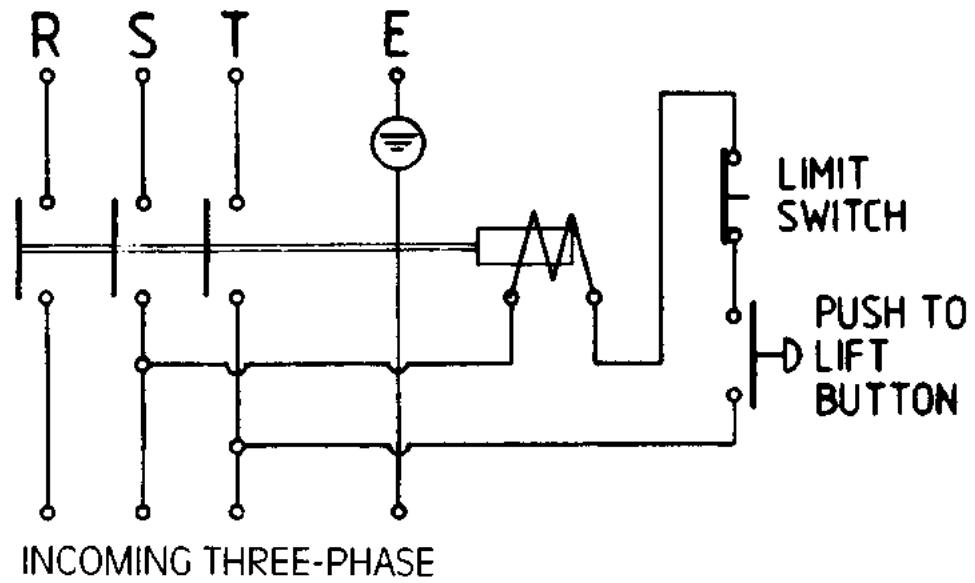

4 POST 1 PHASE

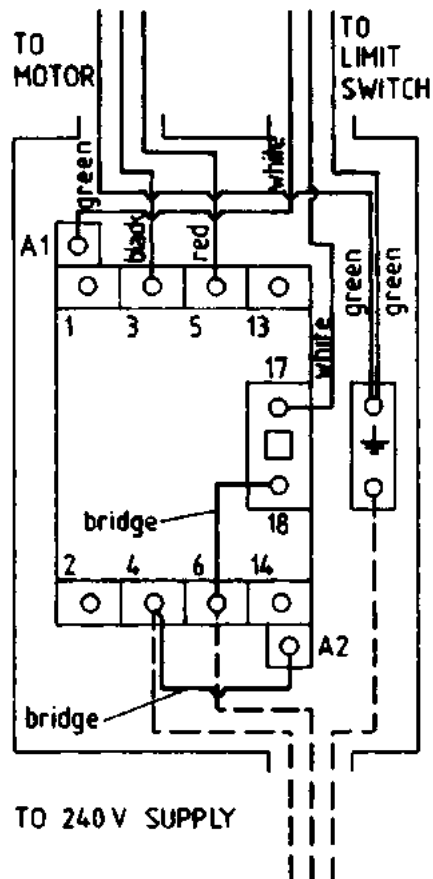

WIRING TO THESE UNITS TO COMPLY WITH AS 3000

GENERAL LAYOUT OF LOCKING MECHANISM

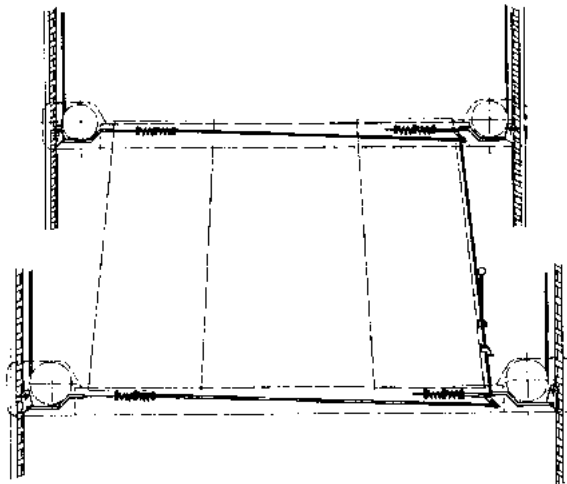

BETABITE HYDRAULICS ASSEMBLY INSTRUCTIONS

FIGURE 20

1. Cut the tube to length and file ends square.
2. Remove internal and external burrs from tube end.
3. We always highly recommend that joints are pre-made whilst the coupling body is held firmly in a bench vice.
4. Ascertain that all the detail parts of the coupling are suitably lubricated, especially the internal body cone, the rear of the ferrule and the internal thread of the nut. The lubrication process is recommended on all fittings, however, on stainless steel couplings the use of a quality lubricant is imperative. Betalube, a copper based paste is highly recommended and available from Betabite Hydraulics or your local distributor. Please note after assembly, fittings to be used on Oxygen lines should be fully degreased.
5. Slide the nut onto the tube, followed by the ferrule, the open end of the nut should be towards the end of the tube, and similarly, the cutting or smaller end of the ferrule should point towards the tube end.
6. Present the tube, nut and ferrule to the coupling body, making sure that tube passes cleanly through the nut and ferrule & butts firmly against the step (abutment face) provided in the coupling body. Screw the nut onto the coupling body until finger tight.
7. Hold the tube in one hand and with the correct sized spanner in the other hand, tighten the nut until the ferrule is felt to just grip the tube. This point is determined by rotation or slightly rocking the tube. From this point, the nut should be tightened $1\frac{1}{4}$ to $1\frac{1}{2}$ turns from the initial ring grip to obtain a fully effective cutting action. On larger sizes of fitting, an extension to the spanner is highly recommended to maximise leverage and minimise effort.
8. If the nut is now removed, the ferrule will have cut its own seating on the tube and whilst it will be found to rotate, it cannot be moved towards the tube end. The 'joint' may now be re-assembled, by re-tightening of the nut until significant resistance is felt and then increase for a further $\frac{1}{8}$ to $\frac{1}{4}$ of a turn. The above procedure must be followed closely to ensure a safe and successful joint.
9. Betabite fittings correctly made can be broken repeatedly, when not under pressure and re-made without affecting their pressure tightness and leak-proof quality.

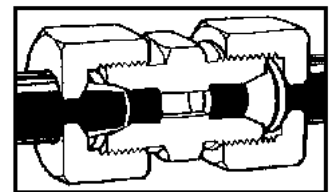
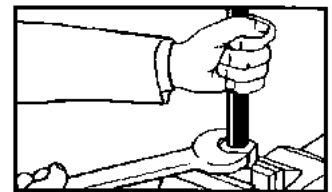
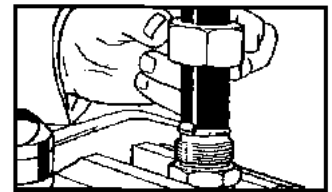
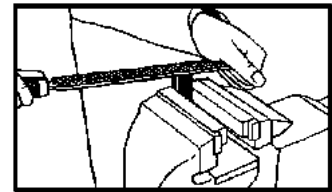

REPLACEMENT PARTS LIST

Part No.	Description	Drawing Ref. No.	Part No.	Description	Drawing Ref. No.
4488-SP-1	No. 1 Post - Standard type	1	4488-DP-98	Twin groove pulley	98
4488-SP-2	Post - Standard type	2	4488-DP-95	Bearing	95
4488-P-3	Safety Rail	3	4488-R-61	Locking mechanism connecting rod	61
4488-P-4	Bolt	4A	4488-R-62	Locking mechanism handle	62
4488-P6A	Shock absorber	ND	4488-R-K63	Locking mechanism mounting bracket	63
4488-P-7	Cable nut	7	4488-R-67	Left platform	67
4488-P-8	Cable #609 No. 1 Post	8	4488-R-68	Wheel alignment recess cover	68
4488-P-9	Cable #610 No. 2 Post	9	4488-R-69	Right platform	69
4488-P-10	Cable #611 No. 3 Post	10	4488-R-68	Wheel alignment recess cover	68
4488-P-11	Cable #612 No. 4 Post	11	4488-R-69	Right platform	69
4488-TB-12A	Transverse beam	12	4488-C-100	Cylinder guide roller	100
4488-TB-13	Cable retaining pin	13	4488-C-AK107	Cylinder assembly	107
4488-TB-17	Nylon pulley bush (2 per pulley)	17	4488-C-K110	Cylinder seal kit	110
4488-TB-24	Pin	24	4488-C-120	Hydraulic hose	120
4488-TB-29	Roller	29	4488-PP	Power Pack Assembly	ND
4488-TB-34	Pawl	34	4488-PP-122	Oil Tank	122
4488-TB-55	Activating Bracket	55	4488-PP-129	Control Valve	129
4488-TB-59	Detent ball assembly	59	4488-PP-150	Hydraulic pump	150
4488-S/W-65	Wheel Stops	65	4488-DRPT	Oil Drip Tray	ND
4488-S/W-66	Run-up ramp	66			
4488-SP-18	Single pulley assembly	18			
4488-SP-80	Bush	80			

NOTE: 'ND' denotes 'Not Drawn'.

NOTE: Model and serial number of hoist must be quoted when ordering parts

FAULT CHART

FAULT	PROBABLE CAUSE	REMEDY
Leakage of oil at joints.	Loose joints in the high pressure pipes.	Inspect the piping and tighten joints.
Leakage of oil at top of Hydraulic cylinder.	Worn Hydraulic seal in hydraulic cylinder	Replace Hydraulic seal or cylinder.
Lack of lifting power.	Problem with Hydraulic Pump Low voltage to Electric Motor	Replace or Repair Hydraulic Pump Contact a Licensed Electrician
Hoist fails to stay up.	Internal leak in Hydraulic Valve	Replace Hydraulic Valve with a new or re-conditioned Hydraulic Valve. Empty Oil. Clean tank and replace Hydraulic Oil.
Hoist does not respond to Operation switch.	Power supply to motor is interrupted. Motor turning in opposite direction.	Check Circuit Breaker. Contact a Licensed Electrician.
Damaged cable	Worn sheaves and sheave pins or bushes	Replace sheaves, sheave pins and cables and bushes.
Load holding topgoggles are not engaging simultaneously or are not releasing simultaneously.	Wire ropes are not correctly tensioned.	Adjust wire ropes as per installation instruction on page 17.

MAINTENANCE

CHECK DAILY

Check safety mechanism to see that it functions properly.

CHECK MONTHLY

Safety mechanism operation.
Condition of sheaves, shafts and shaft locks.
Condition of wire ropes.
Overall cleanliness.

CHECK 3 MONTHLY

Note: The Drip Tray should be inspected following the inspection instructions. Hydraulic oil collected in the Drip Tray could be recycled into the tank or disposed of. Filling the tray with an absorbent material as shown in Figure 22 may assist with the disposal of collected oil.



FIG 22

CHECK 6 MONTHLY

Oil leaks from the cylinder, pipe joints and anchor bolts
Wire ropes
Wire ropes must be inspected by a COMPETENT person.
Inspect for wear, rust and broken wires.
Wire ropes must be replaced if:
At any point the visible number of broken wires exceeds 10 in any length of rope equivalent to 20 times the ropes diameter, i.e. for 13mm diameter rope 10 broken wires in 260mm of cable. A strand of wire is broken.
A rope has been physically damaged by crushing or deforming.

YEARLY

Service and safety inspection on hoist be performed by a competent person. This inspection must be recorded. If the 12 monthly service and safety inspection is not performed, the warranty is null and void. NOTE: Yearly service must include removal of pulleys to inspect and clean bushes.

2 YEARLY

Hydraulic oil should be replaced (irrespective of the amount of use to which the hoist is subjected). Fill Hydraulic Tanks to oil level line with Castrol Hyspin AWH46, Shell Tellus T46, Mobil DTE 25, BP Bartran HV46 or equivalent.

LUBRICATION

Smear the wire ropes once per month with an acid-free grease to guard against rust formation.

OIL CHANGING

1. Lower the hoist to the ground.
2. Clean out the oil tank, using approx. 7 litres of cleaning oil with parafin base.
3. Raise and lower hoist without load once. Drain flushing oil and refill with recommended hydraulic oil.

TOPPING UP

If hoist does not rise to maximum height and motor does not switch off automatically, it is possible that there is insufficient oil in the tank. Lower hoist and replenish with recommended Hydraulic oil.

DRIP TRAY INSPECTION & SAFETY INSTRUCTIONS

1. Using both hands to support the Drip Tray, keeping it parallel to the ground, push up until the bottom of the Drip Tray is above the top of the Ramp Brace Strap.
2. Slide Drip Tray over the Ramp Barce Strap and lower the Drip Tray down when it is clear of obstructions ensuring that the tray always remains parallel to the ground.
3. Visually inspect the Drip Tray for oil and recycle or dispose of oil if present.
4. Clean the outside of the Drip Tray if any oil is present.
5. Relace the Drip Tray following the installation instructions.

When handling and disposing of materials the correct procedures and regulations must be followed. Be familiar with the reguatlions on handling and disposing of Hydraulic Oil before using the Drip Tray. This also applies if an absorbent material is used in the Drip Tray.

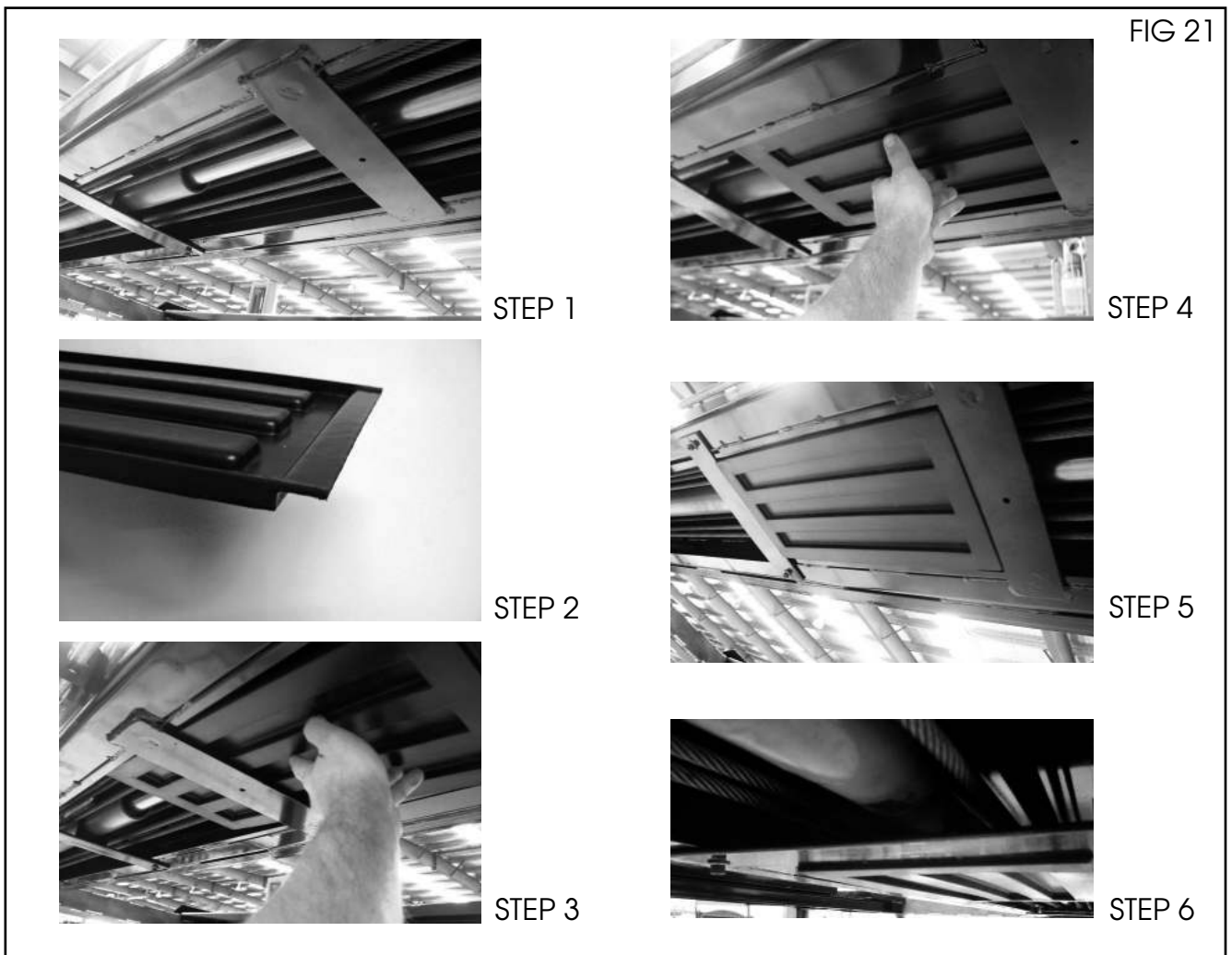

INSTALLATION REQUIREMENTS

INSTALLER MUST CHECK THE FOLLOWING LIST WHEN INSTALLING A MOLNAR FOUR-POST HOIST

1. A suitable floor where the hoist is to be bolted down must have a level surface. When the hoist is bolted down check all nuts and bolts to ensure they are correctly tightened.
2. Check wire ropes and sheaves for possible transport damage or dislocation.
3. When power is connected to the hoist the motor must rotate clockwise. If hoist will not lift exchange wires on two phases (by an Electrician).
4. Check hoist for loose nuts or bolts.
5. Check operation of safety mechanism on all posts, then test hoist with load.
6. Recheck hoist operation. Demonstrate the hoist to the operator.
7. **Very important**
 - 7.1 Instruct operator how to use the hoist.
 - 7.2 Point out maintenance requirements on wire ropes and that they should be checked monthly.
 - 7.3 Point out that by law, the operator and/or owner are responsible for the maintenance and safe operation of the hoist.
8. When all the above points are checked the certificate must be signed by the installer.

WHEELS - FREE RAILS

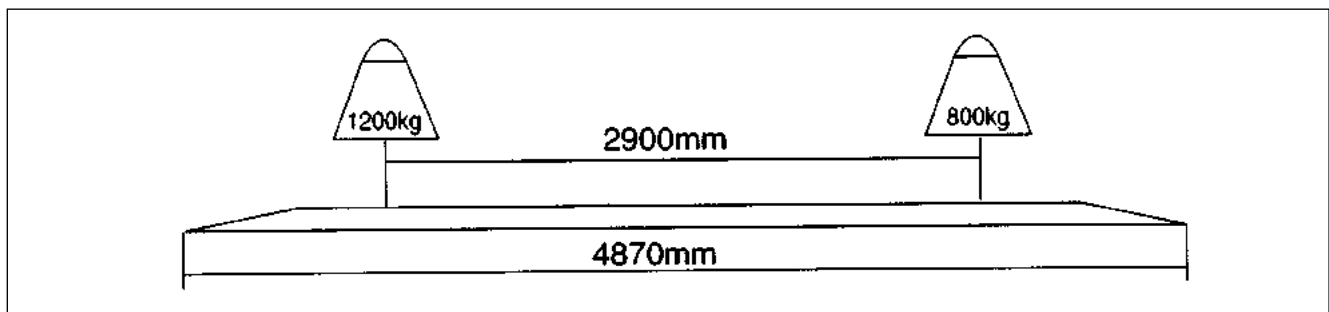

PROCEDURE FOR LOADING RAILS

Each rail has a maximum load of 2000kg, with a 60/40 distribution at a minimum span between the loading points of 2900mm.

Example 1.	Car mass	= 4000kg
	Mass per rail	= 2000kg
	Distribution 60/40	= 1200/800kg
	Min span	= 2900mm
Example 2.	Car mass	= 2600kg
	Mass per rail	= 1300kg
	Distribution 60/40	= 780/520kg
	Min span	= 300mm

NOTE: Lifting the car at the centre of the rails is not advisable (for stability reasons).

CERTIFICATION

I hereby certify that the hoist has been checked and is in a safe operating condition and that the purchaser/operator has been duly instructed in the operation thereof.

Purchaser
Model No
Serial No
Date

Installation by
Address
.....
Name
Signature
Date

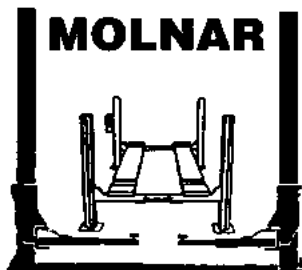

MANUFACTURED BY:

MOLNAR ENGINEERING PTY. LTD.

A.B.N. 54 007 740 794

16-20 Coglin Street, Brompton, S.A. 5007 AUSTRALIA
Telephone: (08) 8346 6893, (08) 8346 6894, (08) 8346 8006
Fax: (08) 8346 0097, Email: sales@molnarhoists.com.au
Web: www.molnarhoists.com.au