

# Nussbaum

## POWER LIFT DG

The Nussbaum DG arm system is not only unique, it provides extreme flexibility in the workshop.

made  
in  
Germany

### DOUBLE JOINTED ARMS INFORMATION

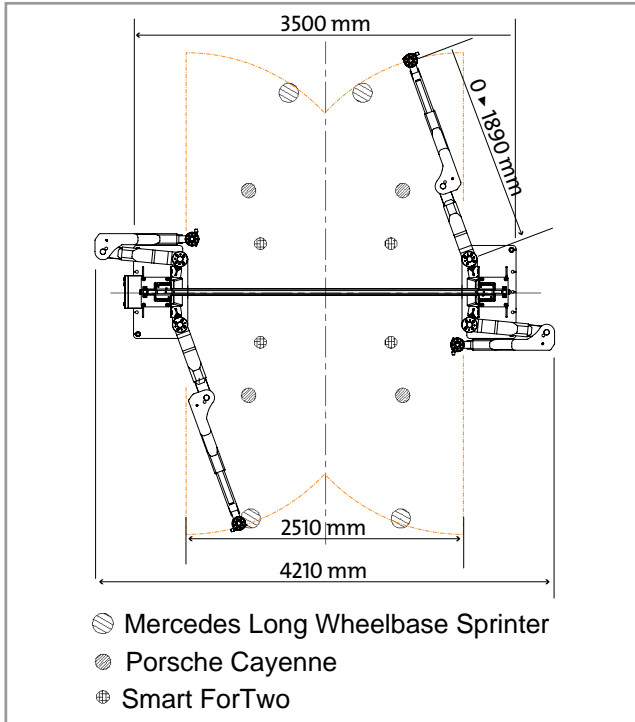

Example vehicle pick up points, possible in DG range.

The Nussbaum DG Double Jointed Arm system used on the Nussbaum 2 post hoist works similarly to two pairs of human arms working in unison to lift a vehicle, only much stronger.

The system provides extreme flexibility to reach a wide range of vehicle pick up points from the Mercedes Sprinters down to Smart cars.



The long reach allows the operator to extend out the arms to pick up points on very long vehicles where stability can be maximised and as such, the lifting safety is vastly increased.

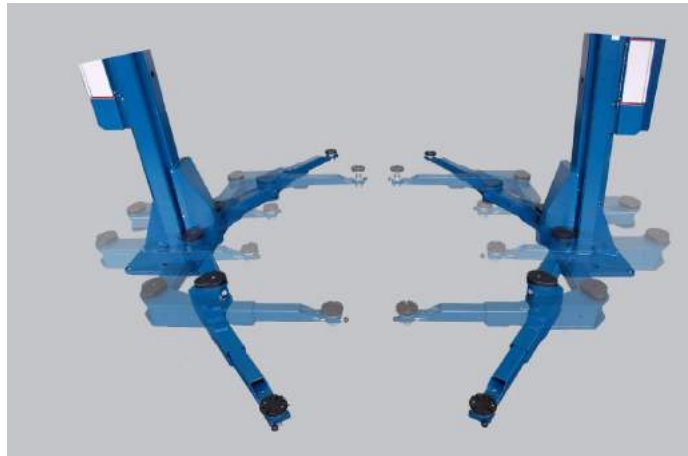

#### PRODUCT SPECIFICATIONS

Footprint	4210 x 4390 mm
Length	1150 ▶ 4390 mm
Width	3500 ▶ 4210 mm
Lifting Capacity	6000 kg
Maximum Raised Height	1980 mm
Minimum Lowered Height	105 ▶ 180 mm
Arm Extension Range	0 - 1890 mm
Drive through Width	2510 mm
Width between columns	2810 mm

#### FEATURES

Operational	
	Double jointed arms
	Height adjustable pickup pads

Manufacturer reserves the right to change specifications without notice.



Molnar Hoists are the Australian agents for Nussbaum, for more information, please contact us on:

T 08 7120 8700 or 1300 MOLNAR (within Australia) F 08 8346 0097  
E sales@molnarhoists.com.au www.molnarhoists.com.au

**onwards & upwards**