

SM270 TWO POST HOIST

7.0 tonne Electro-Hydraulic Two Post Hoist

Operation and Maintenance Manual

**M
O
L
N
A
R**



PART OF THE
STENHØJ GROUP

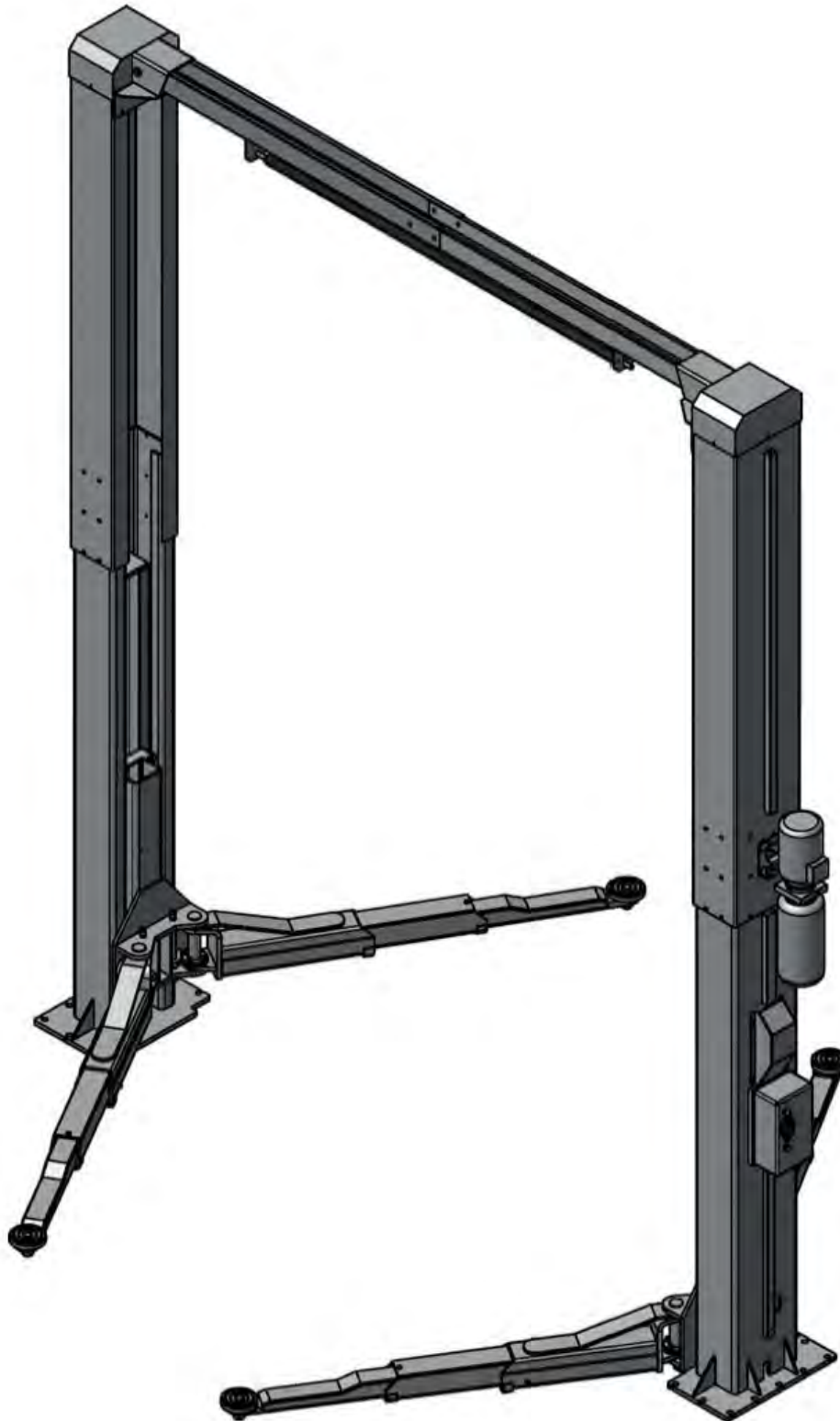

Updated 14/11/2019



Please read this manual before you get started.
You must read and understand the precautions for safety purposes and any damages that may occur to your property.



MOLNAR
PART OF THE STENHØJ GROUP

Address: 3 Graham Street
Export Park
South Australia 5950
Ph: **+61 (08) 8234 3611**
Fax: **+61 (08) 8234 4322**
Email: sales@molnarhoists.com.au
Web: www.molnarhoists.com.au

Specifications/images subject to change without prior notice, Images and sketches are for illustration purposes only.

Table of contents

1	General	4
1.1	Information about the operating manual	4
1.2	Explanation of symbols	4
1.3	Warranty and liability	5
1.4	Spare parts.....	5
1.5	Copyright protection	6
1.6	Waste disposal	6
2	Safety	6
2.1	General	6
2.2	Customer's responsibility	8
2.3	Intended use	8
2.4	Work safety	9
2.5	Personal safety equipment.....	9
2.6	Dangers which may arise from the machine	9
2.7	Operating personnel.....	10
2.8	Behavior in case of danger or accidents	10
2.8.1	Preventive measures	10
2.8.2	If the worst comes to the worst: Do the right things!	10
3.	Technical data	11
3.1	Type designation	11
3.2	Name plate.....	11
3.3	Load distribution.....	11
3.4	Technical specifications.....	12
4.	Structure and function	13
4.1	Description	13
4.1.1	Description of control panel.....	14
4.2	Safety devices fitted on the hoist	14
4.3	Symbols of short operating instructions	15
5	Transport, packing and storage	16
5.1	Safety notes	16
5.2	Transport inspection.....	16
5.3	Packaging	16
5.4	Storage.....	17
6	Installation and start-up	17
6.1	Installation	17
6.2	Start-up	17
7	Operation	18
7.1	Safety.....	18
7.2	Check points before operation	18
7.2.1	Preparations before operation.....	19
7.3	Operation:	19
7.4	Emergency lowering.....	21
8	Maintenance	22
8.1	Safety.....	22
8.2	Maintenance.....	22
8.3	Lubrication.....	23
8.4	Cleaning:.....	24
9	Inspections	24
10.	Malfunctions	25
10.1	Actions in case of malfunctions	25
10.2	Trouble shooting chart.....	25
11.	Oil specifications	27
12	Wiring diagram	28
13	Hydraulic diagram	29

1 General

1.1 Information about the operating manual

This operating manual describes the installation, operation and maintenance of the machine. Strict compliance with all the specified notes on safety and instructions is essential for safe working and proper handling of the equipment.

Apart from that, all accident prevention instructions valid at the place of use and the general safety regulations must also be adhered to.

This operating manual is part of the product and should always be kept in the immediate vicinity of the machine, accessible for the personnel entrusted with installation, operation, maintenance and cleaning.

For better representation of the explanations, the graphical artwork in this manual is not strictly according to scale, but may slightly vary from the actual design of the machine.

The operating manuals of the supporting components apply alongside this operating manual. Please observe the notes contained therein - especially the safety notes.

1.2 Explanation of symbols

Important safety and machine-technical notes in this operating manual are marked with symbols. The notes must be adhered to in order to avoid accidents, personal injuries and damage to property.



WARNING!

This symbolizes dangers that can lead to adverse effects on health, injuries, permanent physical damage or to death.

Adhere at all costs to the notes specified regarding work safety, and be particularly careful in these cases.



WARNING! Danger of electric current!

This symbol draws attention to dangerous situations involving electrical currents. There is a danger of serious injury or death if the safety notes are not complied with. The work may only be carried out by qualified electricians.



ATTENTION!

This symbolizes notes, which if not complied with, can lead to damages, malfunctions and/or breakdown of the machine.



NOTE!

This symbol highlights tips and information that are to be observed for efficient and disruption-free operation of the machine.

1.3 Warranty and liability

All information and notes in this operation manual are provided under due consideration of valid regulations, the latest technical status of development as well as our years of expertise and experience.

The translation of this operation manual has also been made to the best of our knowledge.

We do not accept any liability for errors in translation. The version marked of the operation manual marked with "Original version" on the front page of the operation manual supplied with the hoist shall be binding.

For optional design versions, the use of additional ordering options or the implementation of the latest technical modifications the actual scope of delivery may differ from the descriptions and illustrations in this manual. If you have any questions please contact the manufacturer.



NOTE!

This operation manual must be thoroughly read before starting any work with the equipment, especially before commissioning ! The manufacturer assumes no liability for damages or disruptions that occur as a result of non-compliance with the operation manual.

This operation manual must be kept at the hoist and accessible for all persons working on or with the hoist. Handing over the manual to third party is not permitted and is subject for compensation. Further rights remain reserved.

We reserve the right to technical changes to the product within the framework of improving the usability and further development.

This hoist is guaranteed, covering faults due to manufacturing or material defects, provided that the installation, operation and maintenance instructions are observed. The warranty implies that during the warranty period the manufacturer is committed either to repair or to replace – after own decision - defective spare parts fitted in the hoist. No other warranty claim can be put in under warranty.

1.4 Spare parts

The manufacturer's product/deficiency liability and warranty cannot be claimed if concrete damages or failures are a result of the use of spare parts not originating from the factory.

1.5 Copyright protection

This operating manual is to be treated as confidential. It is solely intended for persons having to work on or with the equipment. Passing this operating manual on to third parties without a written confirmation is not permitted. If this should be required, please contact the manufacturer.



NOTE!

Contents, texts, drawings, pictures and other representations are protected by copyright law and are subject to further commercial protection rights. Any misuse is punishable.

Reproduction of any kind - even in form of excerpts - as well as the utilisation and/or disclosure of its content without the written consent of the manufacturer is not permitted.

Violations oblige to compensation. Further rights remain reserved.

1.6 Waste disposal

If no agreement concerning take-back or waste disposal has been made, disassembled components must be passed on for recycling after correct dismantling:

- Metal material residues must be scrapped
- Plastic elements must be forwarded for recycling of plastics
- Other components must be sorted by material properties



ATTENTION!

Electric scrap, electronic components, lubricants and other auxiliary materials must be treated as hazardous waste and must only be disposed of by specially approved waste disposal companies!

Consumables like greases, oils, conserving and cleansing agents must be removed from the device in a type specific and environmental manner. Use suitable and approved storage containers for the respective consumables. Mark these containers according to their content, filling level and data and store them until final waste disposal in such a way, that any accidental use is ruled out.

2 Safety

This section offers an overview of all important safety aspects for an optimal protection of personnel against danger and ensures safe and disruption-free operation of the machine.

In addition to this, concrete notes on safety to avert danger are provided and marked with symbols in the individual chapters. Furthermore, any pictograms, signs and labels on the machine are to be observed and kept legible at all times.

2.1 General

At the time of development and manufacture the equipment complies with the valid and established technical rules and regulations and is safe to operate. However, danger may arise from this machine if it is used unprofessionally by untrained personnel, or if it is used improperly or not for the purpose it is intended for. Each person entrusted with work on or with the machine must have read and understood the operating manual before starting work.

The customer is advised to demand a written confirmation that all relevant persons have read the operating manual.

Changes of any kind as well as attachments or conversions to the machine are prohibited.

Safety, warning and operation related decals on the machine must always be kept in legible condition. Damaged decals or stickers must be immediately replaced.

Specified settings and adjustment ranges must be strictly complied with.

On the following page you can find the Plant Design Registration Number.

Notice of Plant Design Registration

Registration Number: V1900027

2.2 Customer's responsibility

This operating manual should always be kept in the immediate vicinity of the machine, accessible for the personnel entrusted with installation, operation, maintenance and cleaning.

The machine must only be operated in technically perfect and safe condition.

Always ensure free access to all safety features and check these at regular intervals.

The customer is obliged to determine compliance of work safety measures specified with the current status of legal statutes and to observe any new regulations over the entire period in which the machine is used. The laws on industrial safety and regional directives and regulations valid at the place of use of the machine are to be complied with.

The generally valid notes on industrial safety and accident prevention instructions as well as the valid environmental protection regulations applicable at the place of use are to be observed and adhered to alongside the notes on industrial safety in this operating manual.

The customer and personnel authorized by him/her are responsible for the disruption-free operation of the machine as well as for unambiguous determination of responsibilities during installation, operation, maintenance and cleaning of the machine.

Details of the operating manual are complete and must be adhered to without limitation!

Furthermore, the customer must also ensure that:

- Other dangers that result from special working conditions at the place of use are determined in a risk assessment.
- All other instructions and notes on safety that result from the risk assessment of workplaces on the machine are summarized in operating instructions.

2.3 Intended use

Operational safety is only guaranteed when adhering to the intended use of the device.

This lifting device is specially developed to lift motor cars and we strongly recommend not to lift any other equipment with this automotive hoist.

The lifting platform has been designed and built for the use inside workshops.

Use of the hoist for undersealing of cars and car wash is not allowed.

Riding, climbing and/or standing on the lifting platform as well as using it for lifting or lowering loads other than the ones specified above or installing and operating it outside in an unprotected environment is prohibited.



ATTENTION!

Any other use of the device that differs from this or exceeds this is prohibited and is not considered unintended use!

Claims of any kind against the manufacturer and/or his authorized representatives resulting from damage caused by unintended use of the device are excluded. The customer is solely liable for any damage occurring during unintended use.

Intended use also includes correct adherence to assembly, operating, maintenance and cleaning instructions.

2.4 Work safety

Compliance with the notes on safety can help to avoid personal injury and material damage when working on the machine. Failure to comply with these notes will cause a considerably risk of injury for persons and danger of damage or destruction of the machine.

Non-compliance with the safety regulations causes the exclusion of any liability or compensation claims against the manufacturer or his representative.

2.5 Personal safety equipment

In principle, the following is to be worn when working on or with the machine:

Protective working clothes

Tight fitting work clothing (minimal tear strength, no wide sleeves, no rings or other jewelers etc.)

Safety gloves



Safety boots

for protection against heavy falling down objects and slipping on non-skid proof ground



2.6 Dangers which may arise from the machine

The machine was subjected to a risk analysis. The resultant construction and design of the machine corresponds to the current status of technology.

However, certain remaining risks cannot be avoided!

This device works with electrical voltage.



WARNING! Danger of electric current!

Electrical power can cause severe injuries. There is a danger to life caused by electric current if the insulation or individual components are damaged.

Switch off the main switch and secure against switching on again before maintenance, cleaning or repair work. Switch off the power supply before starting work in the electrical system and make sure that the system is dead. Do not remove any safety features or do not modify such installations in a way that would adversely affect their function.

The equipment is supported by hydraulic components.



WARNING! Danger of injury!

Hydraulic power can cause severe injuries. In case of damage to individual components fluid may escape under high pressure and cause injury and material damage!

Always relieve all pressures before starting work in the hydraulic system.

Do not remove any safety features or make them inoperative as a result of modifications.

Do not change any pressure settings beyond the values specified in this operating manual.

2.7 Operating personnel

The device must only be operated and serviced by authorised, trained and instructed expert persons who:

- are at least 18 years of age and
- have been thoroughly instructed in operation and
- can provide evidence of their suitability to operate lifting platforms and
- have been entrusted in writing by the operating company to operate the lifting platform

An instructed person is someone who has been trained and, if necessary, instructed practically in the tasks entrusted to him/her and the possible dangers resulting from improper actions; and who has been instructed both about the necessary protective features and about protective measures.

Qualified personnel include those who can assess the work entrusted to them and recognize potential dangers based on their specialist training, knowledge and experience as well as their knowledge of appropriate conditions.

If personnel do not have the necessary knowledge, then they are to be trained accordingly.

The equipment must only be operated and serviced by persons who are able to perform their work in a reliable manner. For this purpose, any mode of operation that adversely affects the safety of persons, the environment or the machine is to be avoided. Persons who are under the influence of drugs, alcohol or medication that affects their responsiveness may under no circumstances carry out work on or with the machine.

The employment of personnel must be based on the applicable regulations concerning age and qualification.

The responsibilities concerning operation and maintenance must be clearly specified in order to avoid uncertainties in competence.

The operator must ensure that unauthorized persons keep a sufficient clearance to the equipment.

The operator is obliged to report immediately any changes to the equipment which adversely affect the safety to the operator.

2.8 Behavior in case of danger or accidents

2.8.1 Preventive measures

- Always be prepared for accidents or fire !
- Keep first aid equipment (first aid kit, blankets, etc.) and firefighting equipment close to hand.
- Make personnel familiar with the location and use of safety, accident reporting, first aid and rescue equipment and have this training confirmed.
- Clear access routes for rescue vehicles.

2.8.2 If the worst comes to the worst: Do the right things!

- Shut down the machine immediately.
- Inform the responsible person at the place of use.
- Alarm a physician and the fire brigade.
- Rescue persons from the danger zone, start first aid measures.
- Keep access routes for rescue vehicles clear.

3. Technical data

3.1 Type designation

Example: SM2 70 220-400/3/50

Series designation: SM2

Capacity: 70 = 7000 kg

Mains voltage

3.2 Name plate

The name plate is located on the control post and contains following information:

- Manufacturer
- Serial Number
- Model Number
- Year of Manufacturing
- Max. Capacity
- Design Registration Number

3.3 Load distribution

Front load ratio (F_v) : rear load ratio (F_h)

$F_v : F_h = 3 : 2$ and $2 : 3$

This assumption is based on a vehicle with a wheel base of 1,00 m.

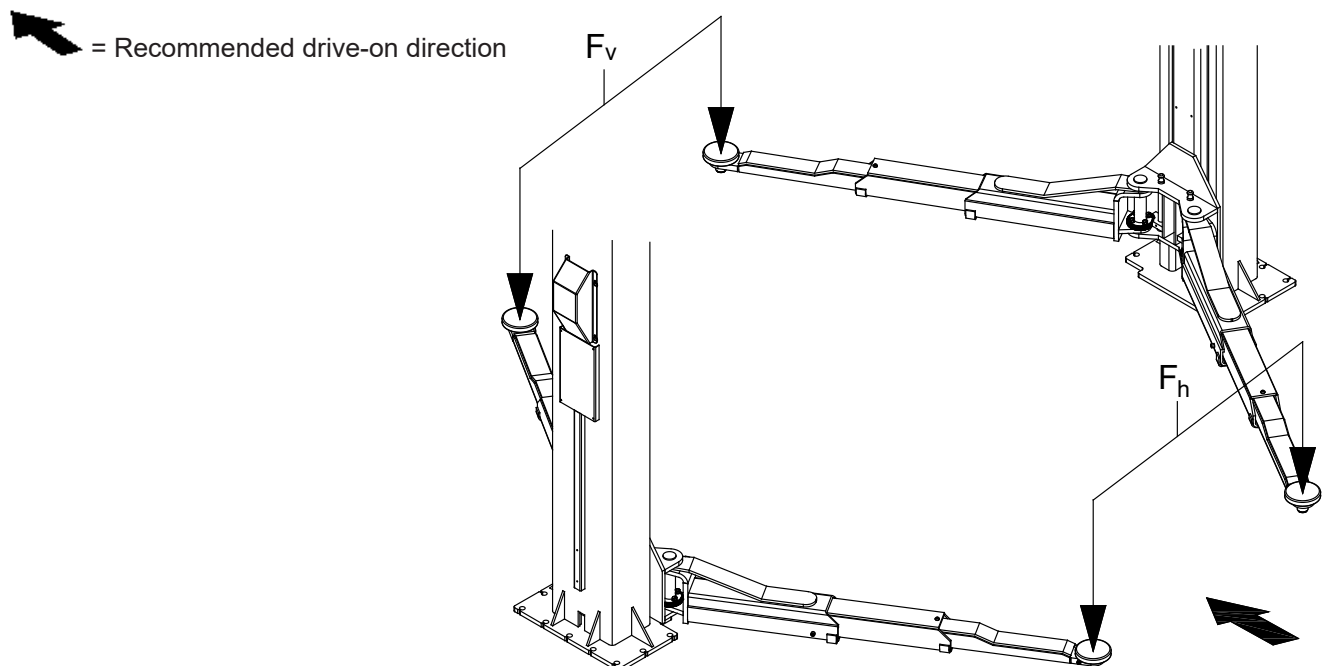

3.4 Technical specifications

	SM270
Max. lifting capacity	7000 kg
Lifting time	65 sec.
Lowering time	65 sec.
Lifting height	1885 mm
Mains voltage Power	415V 3 Phase + Earth

4. Structure and function

4.1 Description



This SM270 hoist is a 2-post electro-hydraulic surface-mounted hoist.

The hoist has a mechanical synchronization system, the two lifting carriages being connected by means of two cables and thereby operate synchronized.

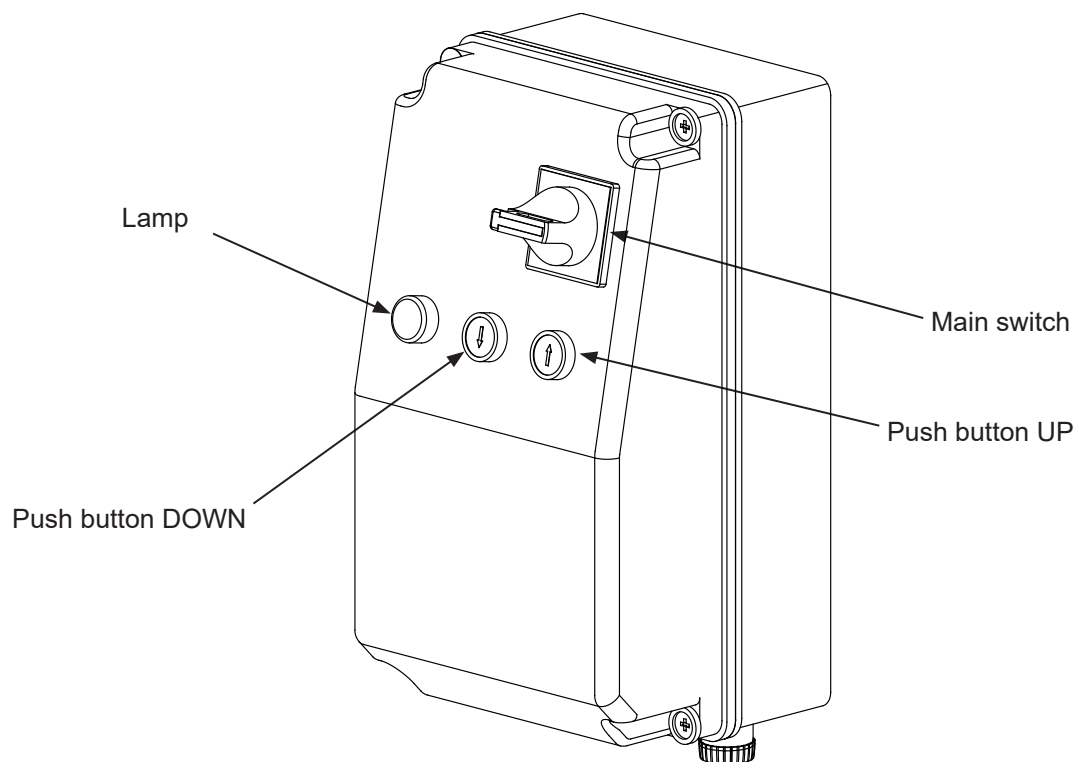
Easy and simple operation by means of "dead-man controlled" pushbuttons placed on the control box - see the below figure.

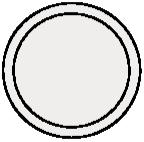
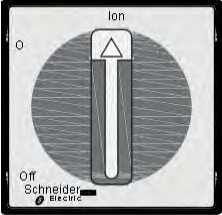

4.1.1 Description of control panel

Switches and lamp	Description
	Power lamp. The power lamp will light up when the main switch is turned ON.
	The CAM switch is the main switch for the supply of power to the hoist. Before the hoist is operated this switch must be turned ON. In event of emergency turn OFF the power to isolate the hoist.
	Push button for moving the hoist upwards. When the CAM switch is positioned to ON and the button is pressed, the hoist moves up.
	Push button for moving the hoist in a downwards direction. When the CAM switch is positioned to ON and the button is pressed, the hoist moves down.

4.2 Safety devices fitted on the hoist

Part	Description
Safety ratchet	The safety lock is attached to the side of the post and prevents the lowering of the hoist in the event of a hydraulic circuit damage. The safety lock is not in operation in the lower part of the hoist range beneath the lock position. (Safety lock is operational at heights above 248 mm).
Check valve	The check valve ensures that the rated lifting capacity is not exceeded.
Cable	The cable connects the 2 hoist carriages left and right to ensure synchronisation at all times and to ensure that they remain at the same horizontal level.
Arm Stop Bolts	The Arm Stop Bolts stop the arms from over extending and sliding out. Check the side and top arm stop bolts are installed, tightened and functioning by extending and testing both stages of all arms

4.3 Symbols of short operating instructions

	<p>The hoist must only be operated by authorised persons. Strict compliance with the comprehensive operating manual is mandatory, especially in case of faults</p>
	<p>Climbing up or standing on lifted load or load bearing device is strictly prohibited.</p>
	<p>After slight initial lifting the operator must check that the load is correctly positioned on the load bearing device. Only then the load may be lifted further.</p>
	<p>Always keep an eye on load bearing device and load when moving the lifting platform.</p>
	<p>No persons must be in the movement range of load bearing device or load while the lifting platform is in motion.</p>
	<p>The movement range of load and load bearing device must be kept clear of any obstructions.</p>

5 Transport, packing and storage

5.1 Safety notes



WARNING! Danger of injury!

There is a danger of injury from falling parts when lifting, swinging and lowering. The machine can be damaged or destroyed by improper transporting.

For this reason, fundamentally observe the following safety notes:

- Only use permissible lifting tackle and sling gear with sufficient bearing capacity.
- Only secure the machine on the fastening points provided; do not fasten onto projecting machine parts or eyelets of attached components. Make sure the sling gear is secure !
- Ropes and chords must be equipped with safety hooks. Do not use any torn or worn ropes. Do not lay ropes and chords on sharp edges and corners, do not knot and do not twist. Pay attention to the centre of gravity of the machine when fastening tackle.
- Never lift, swing or lower loads over people.
- Always move the machine with the greatest of care and attention.



WARNING! Danger of life!

Suspended loads can fall down and lead to severe injuries. Do not stand or pass under suspended loads when transporting with lifting tackle!

5.2 Transport inspection

Check delivery immediately on receipt for completeness and transport damage.

Do not accept delivery or only accept under proviso if there is externally recognizable transport damage. Note the scope of damage on the transport documents/delivery note of the carrier. Start complaints procedure.

Complain about hidden deficiencies as soon as they are discovered as compensation claims can only be asserted within the applicable complaints period.

5.3 Packaging

If there is no returns agreement for the packaging, separate materials according to type and size and direct to further use or re-cycling.



ATTENTION!

Always dispose of packaging materials in an environmentally friendly manner and in accordance with the applicable, local disposal guidelines. If necessary, commission a re-cycling company.



NOTE! Good for environmental protection!

Packaging materials are valuable raw materials and can continue to be used in many cases or sensibly reconditioned and re-cycled.

5.4 Storage

Keep packed goods packed up until installation and store such items as specified on the externally attached installation and storage information.

Store packing units only under the following conditions:

- Do not keep in the open-air.
- Store in a dry and dust-free environment.
- Do not subject to aggressive media.
- Protect against direct sunlight.
- Avoid mechanical vibrations.
- Storage temperature: 15 to 25 °C
- Relative humidity: max. 60 %
- For longer periods of storage (> 3 months), check the general condition of all parts and the packaging at regular intervals. If necessary touch up or renew the conservation.

6 Installation and start-up

6.1 Installation

In order to come up to your expectations now and in the future the hoist must be installed in strict accordance with the installation instructions and maintained according to our recommendations.

As agreed, the equipment will be installed by employees of the manufacturer or by authorized partner companies.

Unauthorized assembly or installation work is not permitted.



WARNING! Danger of injury!

Improper installation and assembly can lead to severe personal injury and/or material damage. Installation and assembly work may only be carried out by trained technical staff while observing the safety instructions.

Contact your distributor for the name and address of the nearest authorized service shop.

6.2 Start-up

As agreed, initial start-up of the equipment will be carried out by employees of the manufacturer or by authorized partner companies.

Unauthorized initial start-up is not permitted.

The machine is handed over to the customer following set-up, initial start-up and implementation of test runs by the manufacturer. After this the machine can be operated in strict compliance with the information in the operating instructions.



WARNING! Danger of injury!

Start-up may only be carried out by qualified technical personnel while observing the safety instructions.

7 Operation

7.1 Safety

Please read the paragraphs "Work safety", "Personal safety equipment" and "Operating personnel".



WARNING! Danger of injury!

During lifting and lowering movements the lifting platform generates dangers which could lead to severe injury, such as crushing or shearing off of limbs or by heavy objects slipping off or falling down.

In order to avoid accidents the following should be noted when operating lifting platforms:

- During the up or down movement of the lifting platform the danger zone and the immediate vicinity of the lifting platform should be free of persons. The distance between persons and the lifting platform should be at least 2 m.
- Accessing the load bearing devices, riding on, climbing onto and standing on the lifted platform is strictly prohibited.
- Do not load the lifting platform beyond the max. permitted load bearing capacity.
- Observe the permitted load distribution (see section "Technical Data").
- Load the lifting platform evenly. Possible shifting of the vehicle's centre of gravity caused by the disassembly of vehicle components must be taken into account.
- Do not initiate any vibration of the lifting platform while performing assembly work on the vehicle.
- Always keep the main switch locked to avoid unauthorised operation and unintended switching on.

7.2 Check points before operation

- Check the below items every day before operation
- During checking, do not load a car on the hoist.
- If faults or errors are detected during using or checking the hoist, stop operation of hoist and request assistance from sales agency. Do not use hoist until it is repaired.

1. Check that hoist operates normally during lifting and lowering. Check that there is no abnormal noise level.
2. Check that hoist operates correctly when buttons are pressed and check that hoist stops immediately when buttons are released.
3. Check for oil leakage from hydraulic lines, hydraulic seals, hydraulic cylinder, and hydraulic unit and that there is no abnormal noise from pump or cylinder.
4. Check that safety lock operates normally during lifting.
5. Check that all nuts, bolts and screws are correctly tightened.
6. Check visually hoist structure, arms, pick-up pads etc. for damages.
7. Check that all electrical functions operate normally.
8. Check that hoist and working area are clean and tidy.

7.2.1 Preparations before operation

Check the following items before loading a car on to the hoist;

1. Ensure that hoist is in bottom position.
2. Prohibit access of unauthorized persons to hoist area.
3. If hoist has been out of use for a long time check oil level in pump unit and top up if necessary. Operate hoist up and down 2-3 times without load.
4. When driving a car on to hoist ensure that car is equally distant from each post.
5. Do not change pre-set safety valve pressure as this is adjusted by manufacturer.
6. If oil level is too low hoist cannot operate effectively. Do not operate hoist under these conditions.
7. Before lowering car hoist, check that hoist area is clear and that there are no persons or obstructions to prevent lowering.
8. Passenger transport on hoist or in/on vehicle is forbidden.
9. During winter season, operate hoist 3 to 5 times without load in $5^{\circ}\sim-20^{\circ}$. Do not use hoist in temperature below -20° .

7.3 Operation:

Positioning of vehicle:

Drive the vehicle in between the 2 posts and turn the 4 telescopic arms under the vehicle.

Lifting:

Position the adjustable arms in order that the skid-proof pick-up pads are placed under the supporting parts of the vehicle.

Place the pick-up pads carefully in order to prevent the car from slipping off. The lifting pad must be loaded centrally ! The load distribution permitted between front and rear arms of 2:3 respectively 3:2 must not be exceeded.

Center of lifting point

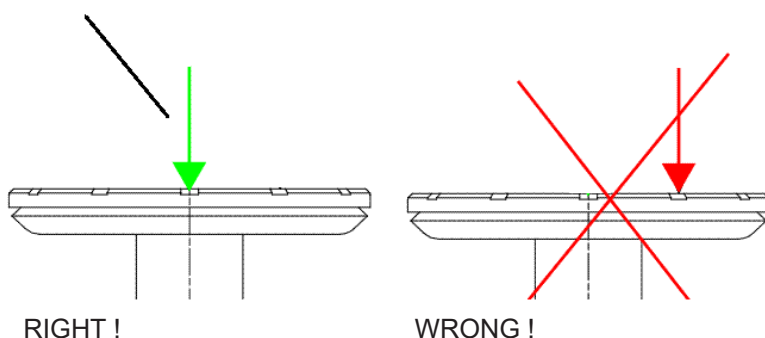

Adjust the pick-up pads in height so as to catch the 4 lifting points simultaneously.

Push UP -button ↑. hoist the vehicle approximately 10 cm.

Check once more that the pick-up pads are correctly placed and make sure that the arm locks are engaged by pulling the arms backwards and forwards.

Lift the vehicle to required working position. Watch vehicle and hoist during the entire lifting movement.

Lowering:

Check that the working area of the hoist is vacant.

Check that all objects have been removed from the working area of the hoist.

Activate Down-button ↓ until the required position has been reached. Watch vehicle and hoist carefully during the whole lowering movement.

7.4 Emergency lowering



WARNING !

During this procedure all normal safety functions are out of operation. Therefore proceed with utmost caution and consideration during the entire procedure.

Only an authorised MOLNAR technician is allowed to carry out the emergency lowering procedure !

- Turn off main switch.
- Remove covers for safety ratchets on both posts (item 1).
- Pull out both ratchets manually (item 2) and fasten them with a string or similar so they do not engage again.
- Remove cap on valve insert (item 3).
- Turn thumbscrew to loosen. Hoist will now lower to bottom position.
- When hoist is in bottom position re-tighten thumbscrew.
- Re-engage ratchets and re-fit covers.

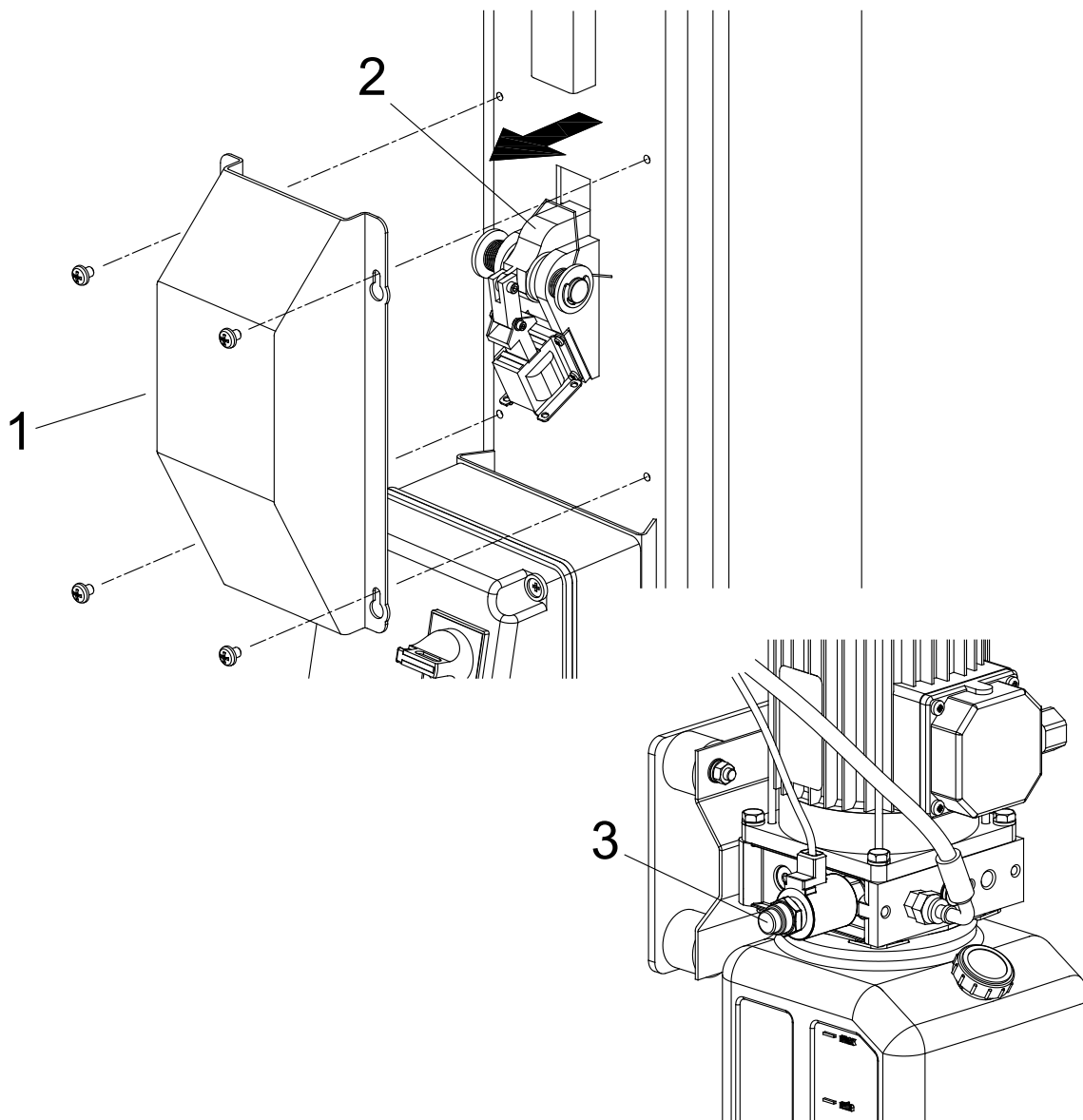

8 Maintenance

8.1 Safety



WARNING! Danger of injury!

Improperly performed maintenance work can lead to severe physical injury or damage to property. Any work related with care and maintenance must only be carried out by qualified and authorized expert personnel.

Strictly observe when performing maintenance work:

- Switch off the system and secure against switching on again.
- Perform work only with the device stopped.
- Secure movable parts against unintended movement.
- See paragraph "Personal safety equipment"



WARNING! Poisoning hazard!

Lubricants are harmful to health! Skin damage (rashes, inflammation, allergies, etc.) can occur on contact of skin with oils and lubricating greases.

Therefore:

- Please observe instructions and safety data sheets from the manufacturer !
- Lubricants are not to be consumed or swallowed. In case of unintended consumption seek medical advice immediately (bring along the packing).
- When handling lubricants, use suitable skin protective and skin-care products or oil-resistance gloves.
- Rinse any spatters in the eye immediately with a lot of water!
- If the skin is dirtied by any lubricants, wash off immediately with soap and water.



WARNING! Danger of injury!

Lubricants which fall on the ground are a source of danger as they present a risk of slipping. Lubricants are to be adsorbed and removed by spreading sawdust or oil adsorption and afterwards scraped according to local environment regulation.

8.2 Maintenance

Oil level check: Check regularly the oil level in tank under pump. Fill up if necessary.

Oil change: First oil change after 6 weeks' operation, thereafter once a year or once per 1500 hoist cycles.

Oil contents: See "Technical specifications".

Oil type: See "Oil specifications".

Expansion bolts:

These must be re-tightened once a year with the following torque:

Model:	Torque:
SM270	240 Nm

Adjustment of cables:

Cables will stretch depending on the operational load and therefore require adjustment as follows, at least once a year:

- Park hoist in adequate working height.
- Check that both carriages are placed at the same height.
- Tighten the lock nut on the two cables, torque 5 Nm.
- Lower hoist again.

Check list and periodic maintenance:

When:	Where:	What:	How ?	Action
Every week	Rubber pads	Wear and deformation	Visually	Replace
	Safety ratchets	Damages	Measure	Replace
	Arm Stop Bolts	Wear and Functionality	Measure	Replace
Monthly	Flex Pad Assemblies	Wear and Functionality	Physically	Lubricate / Replace
Every 3 months	Cables	Wear, breakage og deformation	Visually	Replace
	Pins for arm locks	Funktion of arm locks	Visually	Replace
	Arm locks	Funktion of arm locks	Visually	Replace
	Cover for control unit	Wear and deformation	Visually	Replace
Every 6 months	Sliding blocks	Wear	Visually	Replace
	Electrical components	Damages	Measure	Replace
	Hydraulic oil	Too low oil level	Visually	Replace

8.3 Lubrication

The hoist demands inspection every 6 months only, where all movable parts are to be lubricated as follows:

	Where:	What:	Products recommended:
1.	Guiding edges for nylon sliding blocks inside the post	Lithium grease: Lithium soap grease with high pressure additives, consistence NLGI 2 (apply with brush)	- Castrol APS 2* - Shell Retinax EP 2 - Q8 Rembrandt Moly
2.	Cables	Thin oil	
3.	Suspension for arms	Lithium grease	- see item 1
4.	Arm locks	Lubricating oil	
4.	Flex Pad Assemblies (Thread)	Lubricating spray	

* Lubricated/greased from manufacturer with these products

8.4 Cleaning:

Cleaning of lifts to prevent corrosion damages.

Corrosive fluids as brake fluid, oil, fuel or other solvents must be wiped off immediately, otherwise damage will occur to the coating.

Special attention must be paid to the corrosive effect of salt in fall and winter periods.

The cleansing agents must not have any abrasive effect, nor contain solvents.

The hoist must be cleaned at least once a week.

The hoist must be cleaned with a non-corrosive cleansing agent.

Clean and wipe the hoist according to the following scheme:

When:	Where:	How:	Remarks:
Every week	Pads	Clean and wipe	
	Arms		
	Carriage		
	Post		

The manufacturer does not accept any claim concerning the paint peeling off or corrosion damages caused by missing or insufficient cleaning or maintenance.

Repair of damages:

Repair of damages on the coating must be carried out immediately in order to minimize the extent of the repair.

The damages will typically be:

Damages which do not affect the metal surface but affects the coating itself

Damages going down into the metal surface.

Repairs:

Contact the manufacturer for guidance.

Please state RAL number of paint.

9 Inspections

Before commissioning the hoist must be inspected according to the local national health and safety regulations.

Operational safety and reliability can only be guaranteed when the condition and function of the hoist are inspected at regular intervals – still according to the local national safety regulations.

10. Malfunctions

10.1 Actions in case of malfunctions

In case of breakdown check the following points:

1. Electricity cut
2. Main fuses
3. Electric motor(s)
4. Cable breakage
5. Obstruction under hoist

If these points are found in order but the hoist is still not working, the safety system has probably been activated, and the hoist must not be started or repaired by unqualified staff. Contact the nearest authorized service shop.

Do not start repairing the hoist until the main switch has been cut off.

Do not disconnect the safety system and do not operate the hoist after breakdown and prior to repair.

10.2 Trouble shooting chart

Symptoms		Check points	Remedy
Cable and safety ratchet	Carriages and arms are not at same level during lifting	1. Check if counter nuts at cable bushing are loose	1. Adjust cable to ensure that carriages are at same level 2. Adjust counter nuts and tighten
	Hoist does not lower when DOWN button is activated	1. Check if ratchet is engaged 2. Check if solenoid coil gets tension	1. Raise hoist a little and lower hoist afterwards 2. Repair cable connection if possible, or lower hoist manually according to emergency lowering procedure
	Carriages and arms are not at same level during lowering	1. Check oil level 2. Check if there is air in the hydraulic system.	1. Fill in oil to correct oil level 2. Bleed hydraulic cylinder
	Safety ratchet does not work, neither during lifting or lowering	1. Check solenoid coil at ratchet	1. Re-fit if necessary and contact autopstenhoj
Cylinder and pump unit	Abnormal noise from motor	1. Max. lifting capacity is exceeded 2. P-max (setting of pressure control valve) is set to low 3. Not sufficient hydraulic oil	1. Limit load to max. capacity or less 2. Adjust to P-max (see technical specifications). 3. Bleed cylinder and fill in oil to correct oil level
	Oil leakage	1. Defective hydraulic hoses 2. Oil leakage from hydraulic unions 3. Defective cylinder seals	1. Replace hydraulic hose 2. Tighten hydraulic unions 3. Call authorized engineer

Symptoms		Check points	Remedy
Cylinder and pump unit	Polluted oil	1. Hydraulic oil polluted by water or other foreign debris	1. Oil change - see oil specifications 2. First oil change 6 weeks after installation 3. Afterwards regular oil changes (see section 8.2)
	Hoist does not rise	1. Check for oil leakage or damages on pump unit 2. Check that permissible max. capacity is not exceeded 3. Check that pressure on pressure control valve (P-max.) is correct	1. Call for authorized engineer 2. Limit load to max. capacity or less 3. Adjust valve (see technical specifications)
	Hoist does not lower	1. Check if safety ratchet is engaged 2. Check if mains supply is correct	1. Raise hoist a little and afterwards lower 2. Check according to the electrical points
	Lower hoist manually according to emergency lowering procedure and contact afterwards the distributor for assistance		
Electrical components	Motor does not work and/or an abnormal noise from motor is heard	1. Check if motor is damaged 2. Check if fuses are blown 3. Check if push button is defective 4. Check if top limit switch is working 5. Check if motor cable is connected correctly 6. Check that mains voltage is not lower than 200 V	1. Replace motor (call for authorised engineer) 2. Replace fuses 3. Replace push button (call for authorized engineer) 4. Lower hoist and start again 5. Replace supply cable with cable of at least $\varnothing 3,5 \text{ mm}^2$ 6. Increase mains voltage
	Main switch (16 A) is activated	1. Check coil for contactor 2. Check capacity of main switch 3. Check if cable is defective	1. Replace (call for authorised engineer) 2. Replace (call for authorised engineer) 3. Replace after checking
	Motor works but hoist does not rise	1. Check that phases are connected correctly and that motor runs anti-clockwise 2. Check that hydraulic hoses are defective	1. Interchange phases and start again 2. Check according to points for hydraulic cylinder and pump unit

11. Oil specifications

46 Weight AWH Oil is recommended
Example: Castrol Hyspin AWH 46 (14L)

12 Wiring diagram

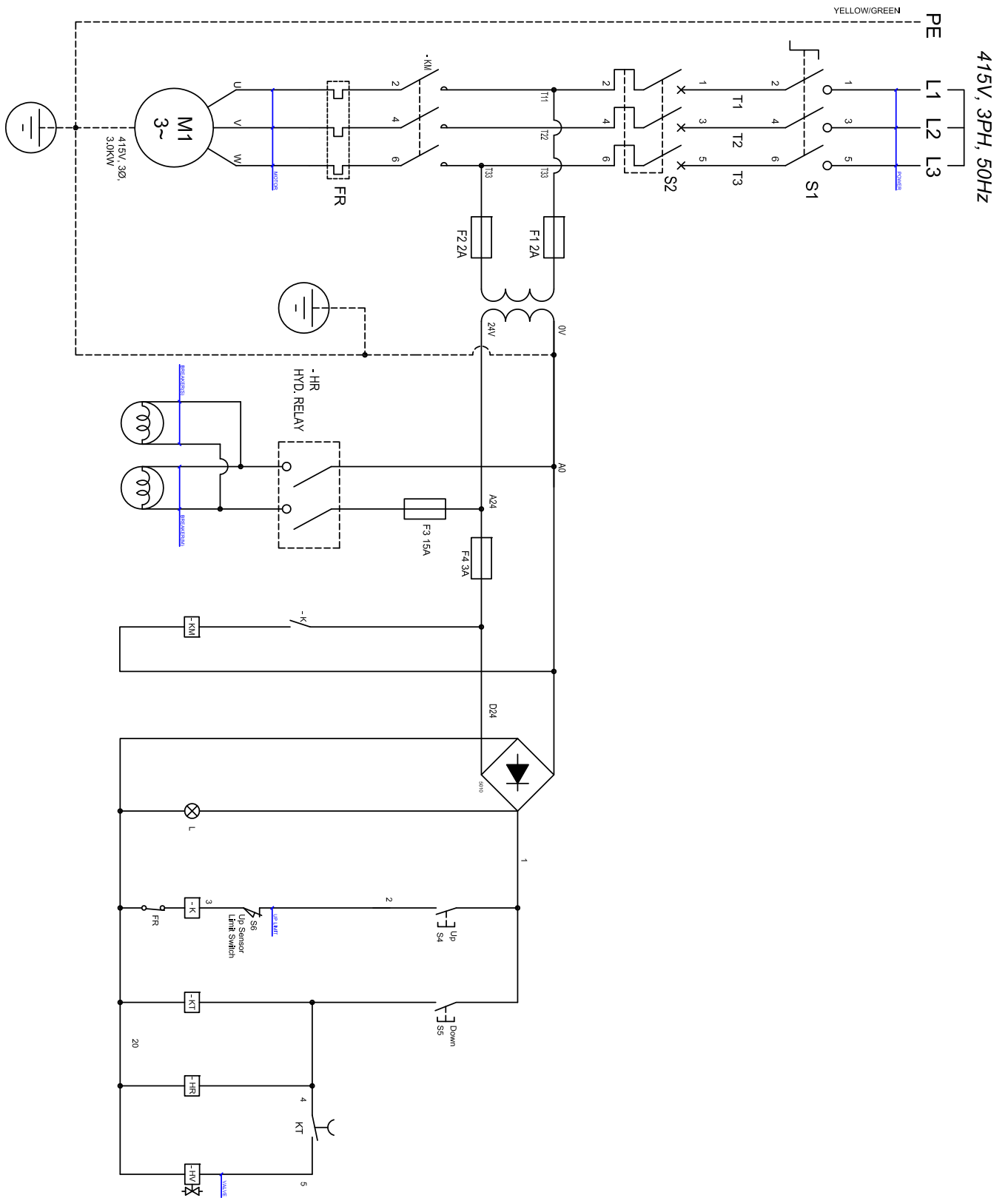

13 Hydraulic diagram

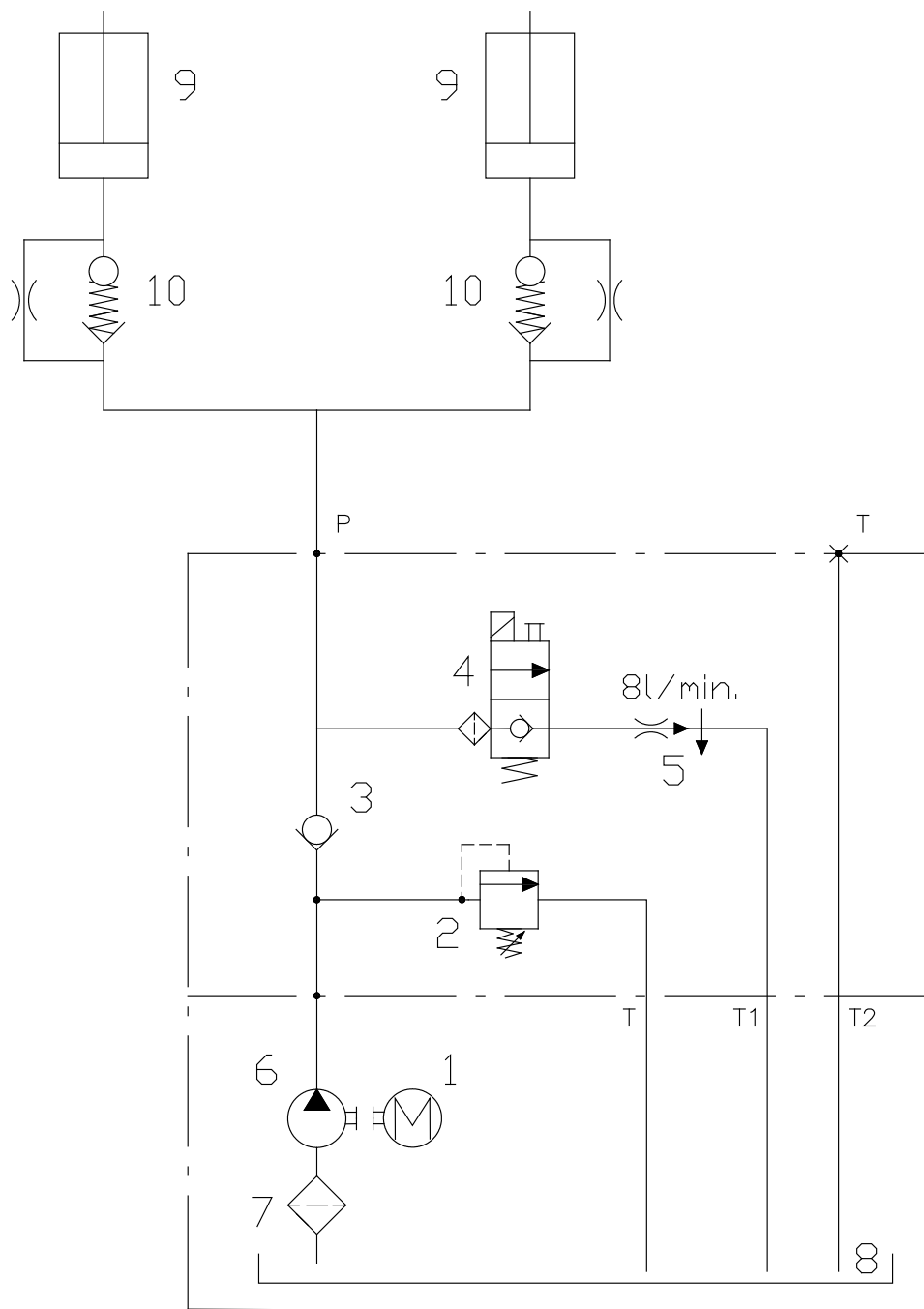

1. Motor
2. Pressure control valve
3. Non-return valve
4. Solenoid valve
5. Flow-restricting valve
6. Pump
7. Filter
8. Oil tank
9. Cylinder
10. Flow-restricting valve