



LASER-2.2 CP

Stand alone or shared column car stacker – 3 tonne capacity



MOLNAR LASER-2.2 CP is a hydraulic 2-post premium car stacker which can work either as stand alone or multiple units with a shared column.

MOLNAR Parking system will create twice as much parking space.

The parking system serves as dependent parking. Space below has to be free to park on the platform above.

Ideal locations

- › Car repair workshops
- › Car dealerships
- › Private car parking
- › Car rental area
- › Valet parking
- › Residential sites
- › Commercial sites
- › Building development sites

Optional Extras

- › Single phase
- › Custom colours
- › Standard colour (RAL7016) ●

Service and Support

- › 3 year Molnar warranty
- › National service network

Features

- › 100% more parking space
- › 3000 kg lifting capacity
- › Maximising the number of available parking spaces
- › Easy to install for private or commercial
- › Low requirements on the installation area
- › Above-ground without pit
- › Safe, low maintenance
- › Operation via key-switch
- › Small footprint allows multiple installs in limited space with shared column

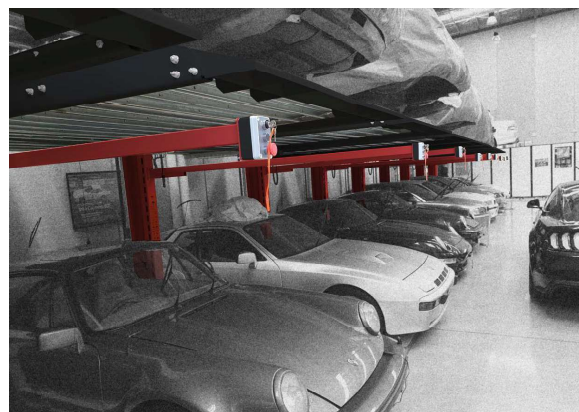

Application



Space saving

Specifications

Lifting capacity	3,000 kg
Clearance below	2,140mm
Overall width	2,618mm for stand alone 2,453 mm if sharing column
Overall length	4,274 mm
Overall height	3,510mm
Platform width	2,244 mm
Clearance between columns	2,288 mm
Platform length	4,175mm
Lifting time	50 seconds
Voltage	415V 3 Phase + Earth / 10A (Neutral NOT required) Optional single phase / 16A

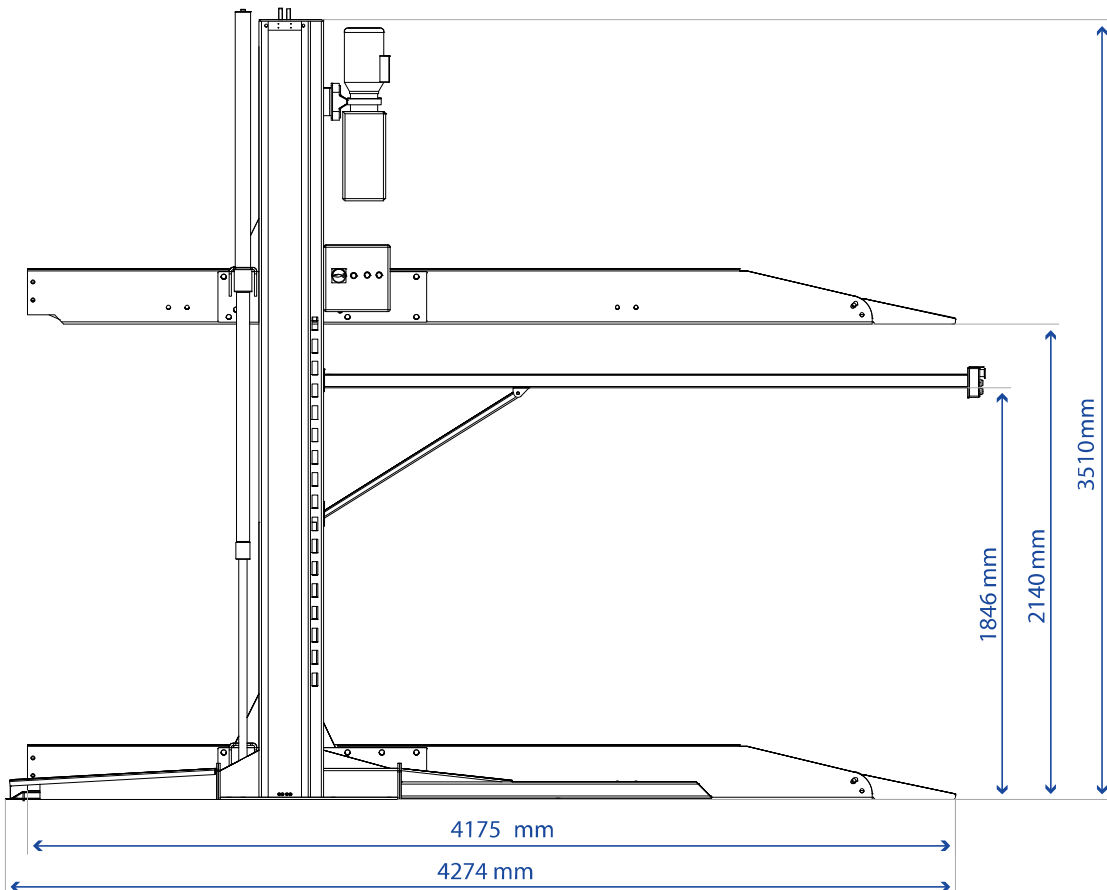
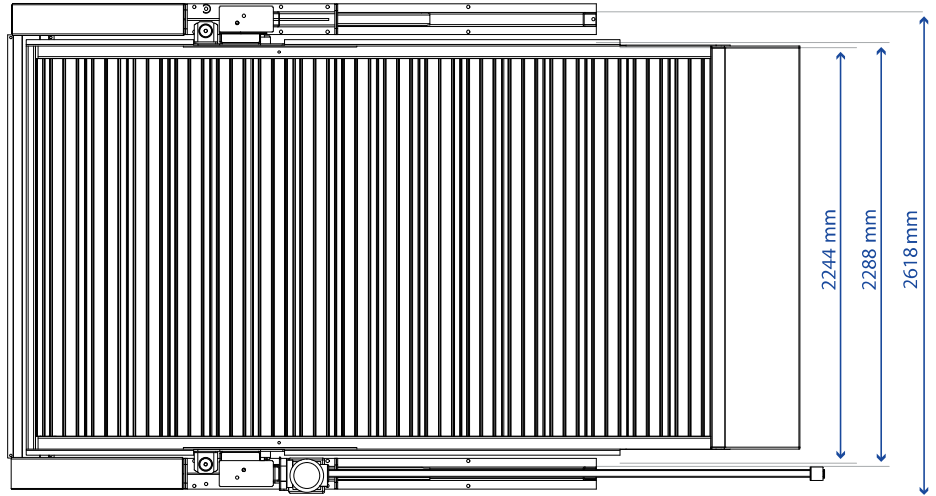

Specifications/Images subject to change without prior notice. To validate warranty, proof of a valid maintenance contract will be required. Images and Illustrations are indicative and may be modified without notice

Lifting
the Level

For more information, please contact MOLNAR or your local MOLNAR Representative

☎ 1300 MOLNAR (1300 665 627)
☎ 08 8234 3611 📠 08 8234 4322
✉ sales@molnarhoists.com.au

www.molnarhoists.com.au

🌐 📺 MolnarAustralia

Shared Column Dimensions

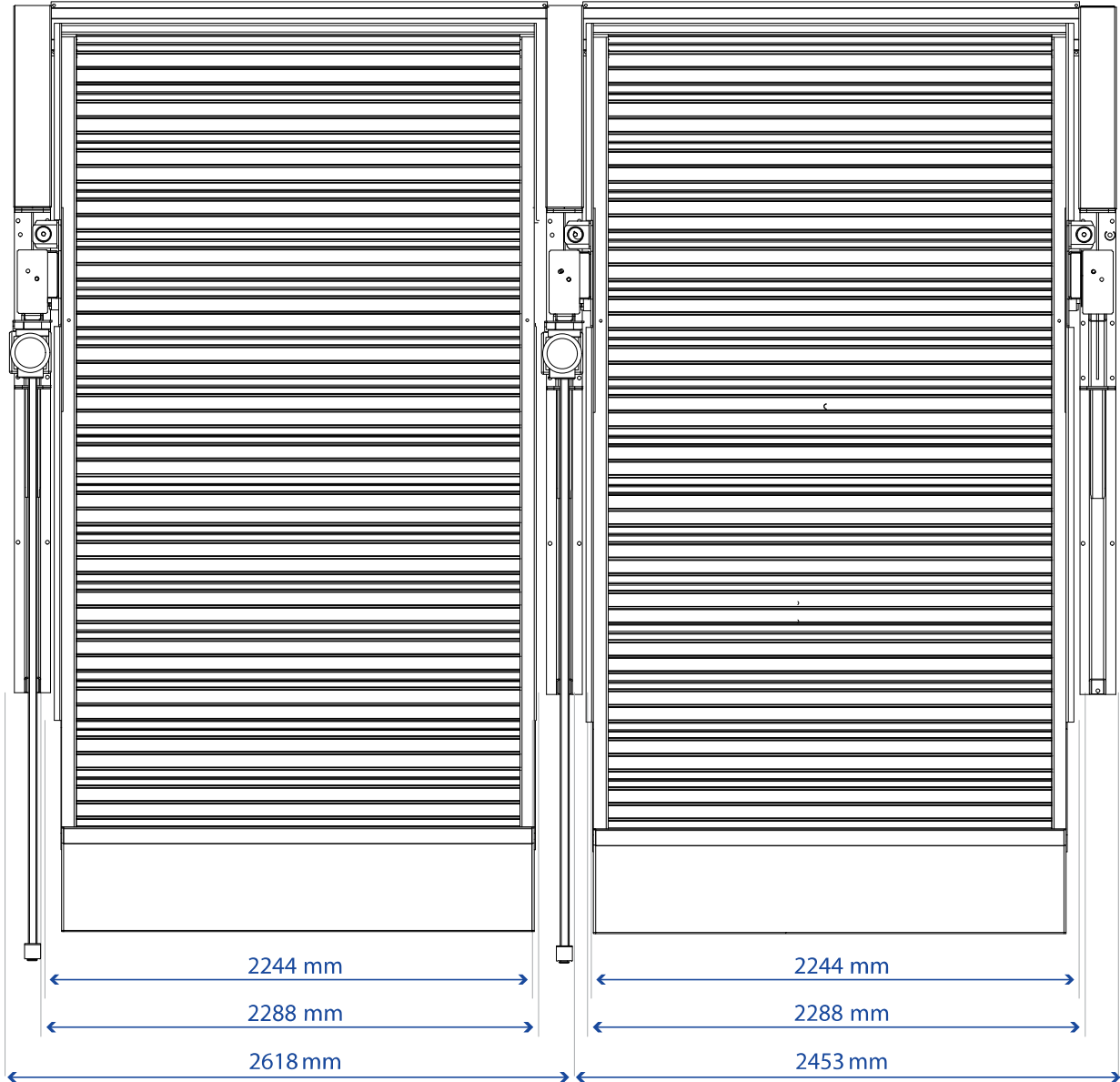

Specifications/Images subject to change without prior notice. To validate warranty, proof of a valid maintenance contract will be required. Images and Illustrations are indicative and may be modified without notice

Lifting
the Level

For more information, please
contact MOLNAR or your
local MOLNAR Representative

www.molnarhoists.com.au

☎ 1300 MOLNAR (1300 665 627)
 ☎ 08 8234 3611 📠 08 8234 4322
 ✉ sales@molnarhoists.com.au

🌐 www.molnarhoists.com.au   MolnarAustralia