

CM360

FULL RISE DOUBLE SCISSOR



MOLNAR
By NEXION

Technical Data	Lifting capacity	3600 kg
	Lifting height	2030 mm
	Working height	110 mm – 2030 mm
	Lifting / lowering time	approx. 40 seconds
	Motor unit	3.0 kW
	Voltage	400V 50-60Hz 16A (single phase available)
Scissor Platforms	Platform Length	1885 – 2204 mm
	Platform Width	628 mm
	Distance Between Platforms	800 mm
	Max. distance scissor - control box	2000 mm
	Minimum Height	110 mm



Description:

- Double master / slave hydraulic system, no compressed air or safety lock necessary
- Control box with push buttons, integrated pump unit and alarm signal
- Emergency lowering valves can be manually opened
- Sturdy scissor construction for high directional stability
- Ramps made from tear plates, for easy drive-on with wet wheels
- No mechanical connection between scissors for clear access between platforms
- Low minimum height of 110mm suitable for low vehicles and drive over situations.
- No fixed drive on direction, control box can be installed either side of scissors.

Standard Colours:

- Platforms: RAL 9005 - Black
- Scissor: RAL 2002 - Red
- Custom colours available

Extras & Accessories

- Range of rubber blocks
- Cross bar for lifting 4x4 vehicles
- Single phase

Service & Support

- 3 year warranty
- Spare parts stocked locally in Australia for 24 working hour dispatch

Specifications/Images subject to change without prior notice. To validate warranty, proof of a valid maintenance contract will be required. Images and Illustrations are indicative and may be modified without notice

CM360

Full Rise Electro-Hydraulic Double Scissor Hoist - 3.6T onne Capacity



MOLNAR
By NEXION

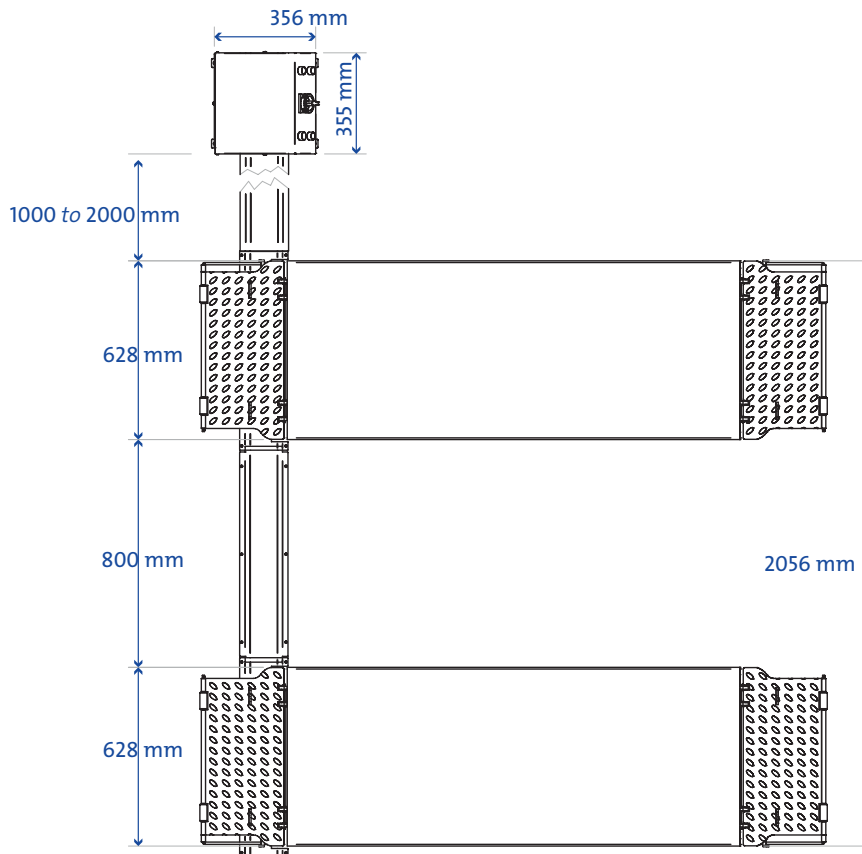
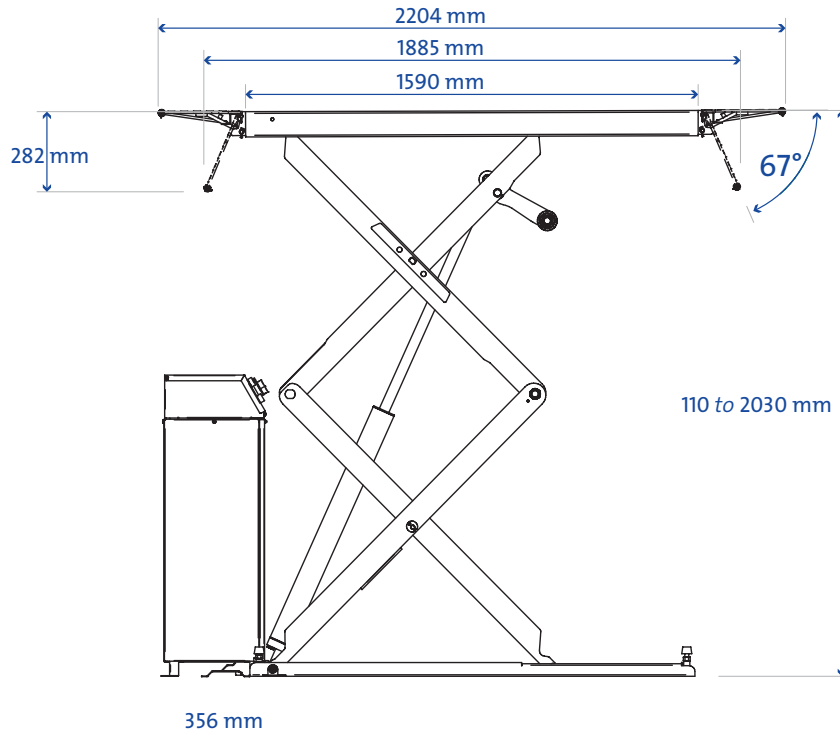

Specifications/Images subject to change without prior notice. To validate warranty, proof of a valid maintenance contract will be required. Images and Illustrations are indicative and may be modified without notice

**Lifting
the Level**

For more information,
please contact MOLNAR or your
local MOLNAR representative

www.molnarhoists.com.au

☎ 1300 MOLNAR (1300 665 627)
☎ 08 8234 3611 📠 08 8234 4322
✉ sales@molnarhoists.com.au

🌐 📘 MolnarAustralia