



SM270

Electro-Hydraulic Two Post Vehicle Hoist – 7 Tonne Capacity



The Molnar SM270 is a universal 7 tonne electro-hydraulic two post vehicle hoist, available with three phase or optional single phase motor. This hoist is ideally suited for vehicle repair and maintenance within industrial, commercial or domestic workshops.

The post profile and large foot plate offer unrivalled stability for stronger, smoother operation. The double telescopic arm length makes the SM270 one of the most versatile on the market suitable for vehicles up to 7 tonnes.



Features

Posts

- › 7 tonne lifting capacity
- › Clear floor (no base frame)
- › Single hydraulic unit
- › Carriage with slide blocks
- › Push button control unit with upper protection limit
- › Mechanical synchronisation
- › Safety ratchet system (no expensive compressed air required)

ARMS

- › Double telescopic front and rear arms as standard
- › Automatic arm locking system
- › Minimum pad height 105 mm
- › Long reach front and rear arms suitable for many passenger vehicles

Settings

- › Standard width 3992 mm
- › Standard height 4915 mm
- › 187 mm pad extension included

Optional Extras

- › Single Phase
- › Custom colours
- › 100 mm pad extensions
- › OEM approved adapter sets

Accessories

- › Range of lifting pads
- › Installation kit – oil and bolts

Service and Support

- › 3 year Warranty
- › Available spare parts; shipped within 24 working hours

Application



Repair and maintenance



Technical Data	Lifting capacity	7000 kg
	Lifting height	1885 mm
	Working height	1885 mm
	Lifting / lowering time	65 seconds
	Motor unit	3 kW
	Voltage	415V 3 Phase + Earth (Neutral NOT required) 240V single phase optional
Arm Structure	Lifting pad	105 – 135 mm adjustable
	Minimum height	105 mm
	Drive-through width	2900 mm
	Width between posts	3330 mm
	Total width - outer edges base plates	3992 mm
	Total height including post	4915 mm
	Arm length front, minimum – maximum	900 – 1820 mm
	Arm length rear, minimum – maximum	900 – 1820 mm

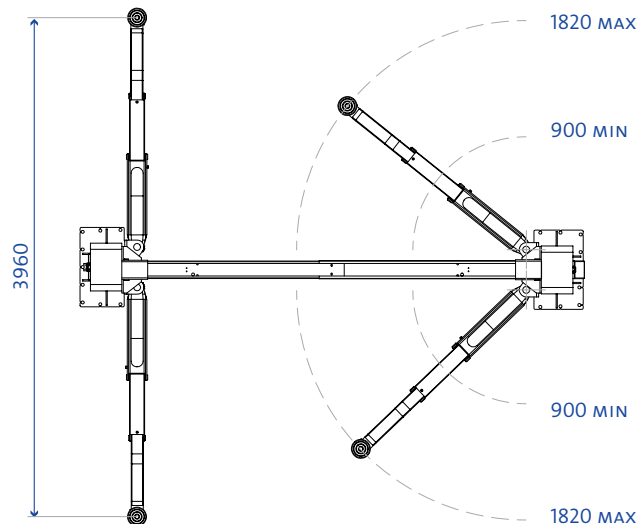
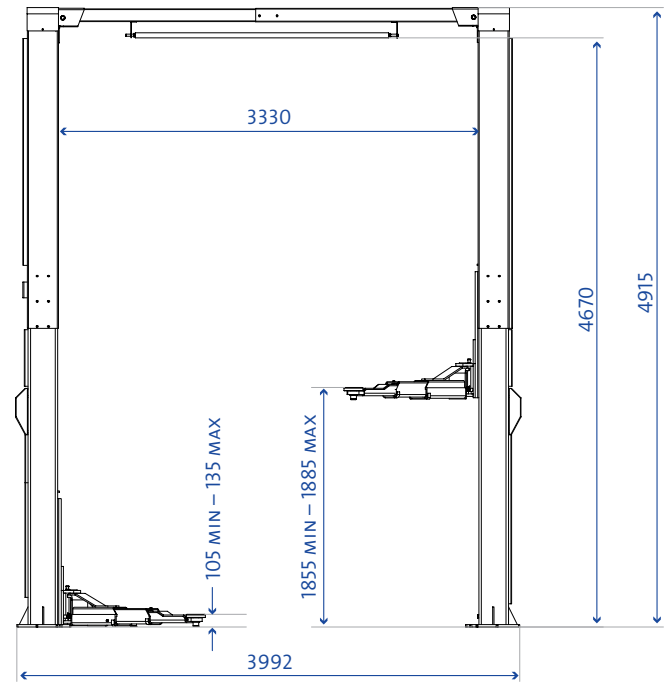

Dimensions in mm. Specifications/Images subject to change without prior notice. To validate warranty, proof of a valid maintenance contract will be required. Images and Illustrations are indicative and may be modified without notice

**Lifting
the Level**

For more information,
please contact Molnar or your
local Molnar Representative

☎ 1300 MOLNAR (1300 665 627)
☎ 08 8234 3611 📠 08 8234 4322
✉ sales@molnarhoists.com.au

www.molnarhoists.com.au

🌐 📺 MolnarAustralia

SM270

Electro-Hydraulic Two Post Vehicle Hoist – 7 Tonne Capacity

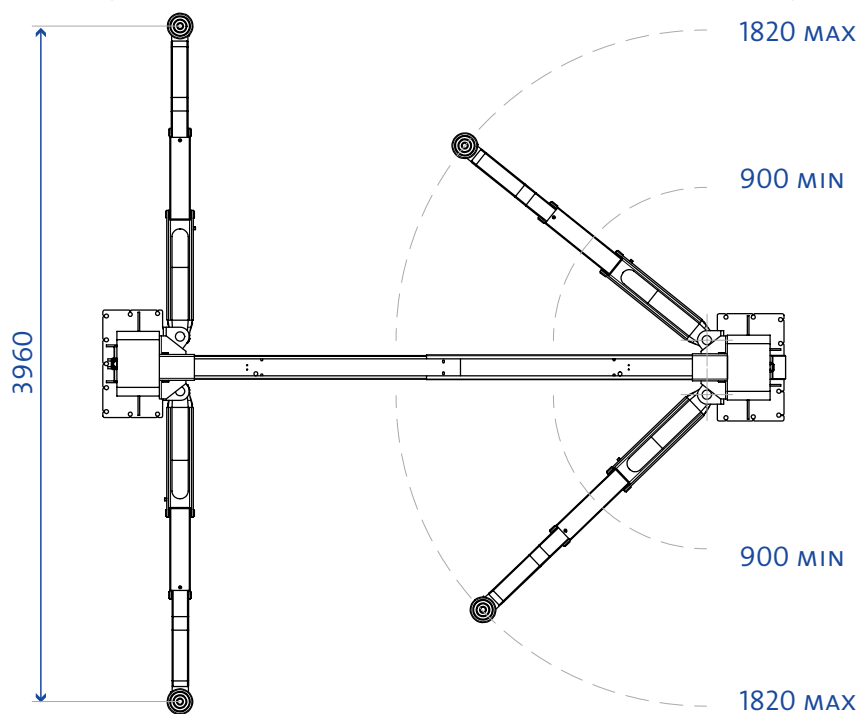
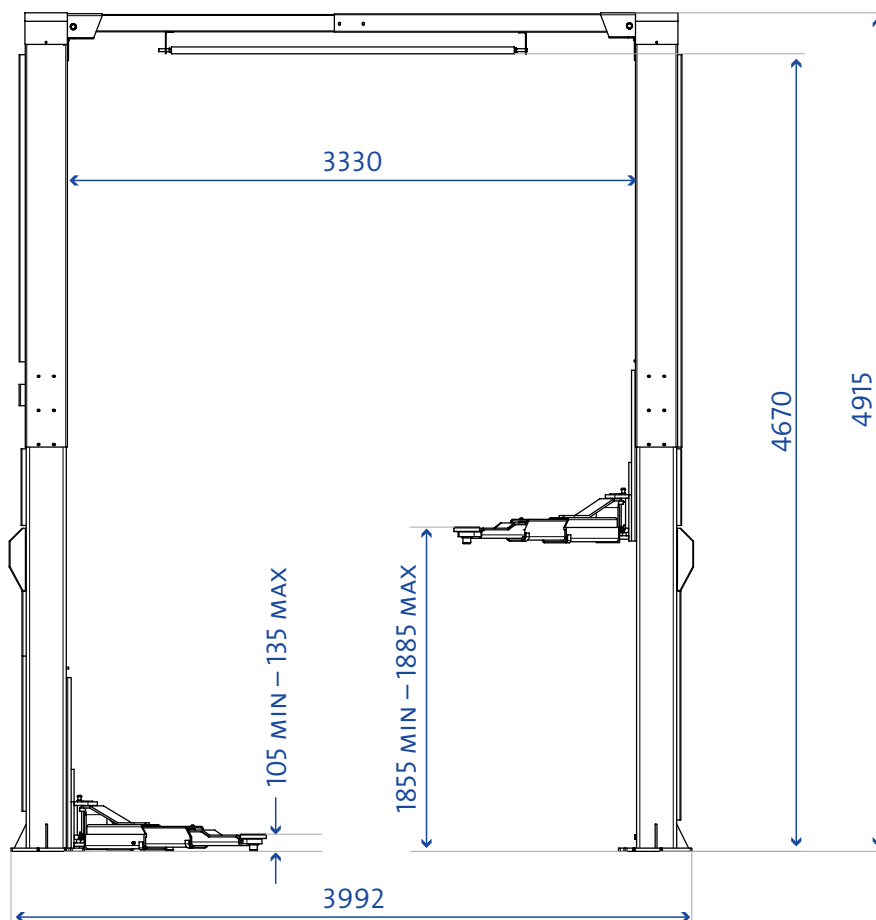

Dimensions in mm. Specifications/Images subject to change without prior notice. To validate warranty, proof of a valid maintenance contract will be required. Images and Illustrations are indicative and may be modified without notice

*Lifting
the Level*

For more information,
please contact Molnar or your
local Molnar Representative

www.molnarhoists.com.au

☎ 1300 MOLNAR (1300 665 627)
☎ 08 8234 3611 📠 08 8234 4322
✉ sales@molnarhoists.com.au

🌐 www.molnarhoists.com.au MolnarAustralia