

# SM245 TWO POST HOIST

Universal 4.5 tonne Electro-Hydraulic Two Post Hoist

## Installation Manual



**M  
O  
L  
N  
A  
R**



PART OF THE  
STENHØJ GROUP

Updated 22/03/2023

## Contents

|   |                  |
|---|------------------|
| <b>Installation Instructions</b>          | <b>Page 3-21</b> |
| <b>Installer Checklist</b>                | <b>Page 22</b>   |
| <b>Appendix A – Lowering Valve Detail</b> | <b>Page 23</b>   |



Please read this manual before you get started.

You must read and understand the precautions for safety purposes and any damages that may occur to your property.

If these installation instructions are not followed strictly, the hoist is not covered by warranty.



**MOLNAR**  
PART OF THE STENHØJ GROUP

|          |  |
|----------|--|
| Address: | 3 Graham Street<br>Export Park<br>South Australia 5950                   |
| Ph:      | <b>+61 (08) 8234 3611</b>  |
| Fax:     | <b>+61 (08) 8234 4322</b>  |
| Email:   | <a href="mailto:sales@molnarhoists.com.au">sales@molnarhoists.com.au</a> |
| Web:     | <a href="http://www.molnarhoists.com.au">www.molnarhoists.com.au</a>     |

Specifications/images subject to change without prior notice, Images and sketches are for illustration purposes only.

These instructions indicate step by step how you ensure a trouble-free installation and correct operation. It is therefore of **vital importance** that you take the necessary time and care to ensure that the installation tolerances are not exceeded, otherwise the hoist will not function effectively, and you will not benefit fully from your new purchase.

**NB: Note this arrow → . The hoist will throughout these instructions be shown from the drive-on direction.**

**NB: If these installation instructions are not followed strictly, the hoist is not covered by warranty.**

**Information for construction engineer or architect:**

| Model | Concrete Floor requirements                                    | Anchor Bolts                  |
|-------|--|-------------------------------|
| SM245 | Recommended floor thickness 140mm thick, 32MPa grade, F82 mesh | Thru-Bolt<br>20mm D X 160mm L |

**Expansion bolts used for the installation of the hoist in crack free concrete:**



Thru-Bolt  
20mm D x 160mm L  
Iccons Part No. TB20160

\*If alternative attachment is used the properties must at least meet the corresponding bolt mentioned above.

**Information for Installers:**

The hoist must be installed on an even floor and must not be installed in or close to construction joints (min. distance = 200 mm). Ensure the floor is in good condition and the hoist is positioned away from cracks and old anchor bolts. The maximum thickness of any shimming is 5mm, any thickness over this amount then longer anchor bolts must be used.

(Expansion bolts not included in delivery)

**Floor Repair Information**

If floor is less than 140mm thick or if the anchor bolts cannot be torqued to recommended setting, the floor will need to be cut out to the following specifications.

Cut the existing floor to a minimum pad size of 4000mm x 2200mm, dig out base to a depth of 200mm minimum and undercut existing slab by 200mm.

Ensure the base is compacted to 95% MMDD.

Insert pins in old slab to lock the slabs together.

Concrete must be a minimum of 32 MPa grade and a depth of 200mm Steel mesh must be a minimum of F82.

Slab must be let to cure for a minimum of 28 days before installing the hoist.

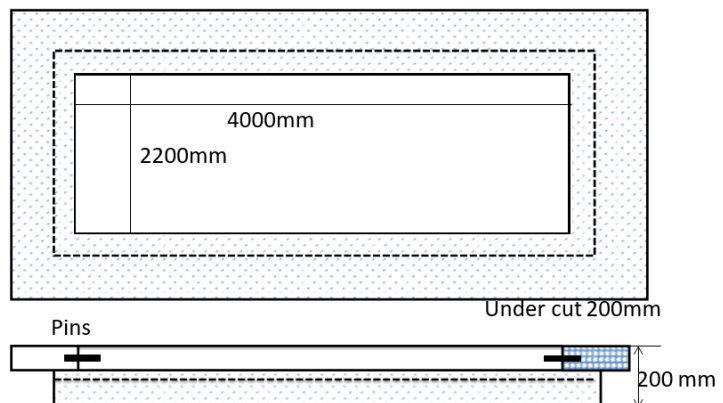

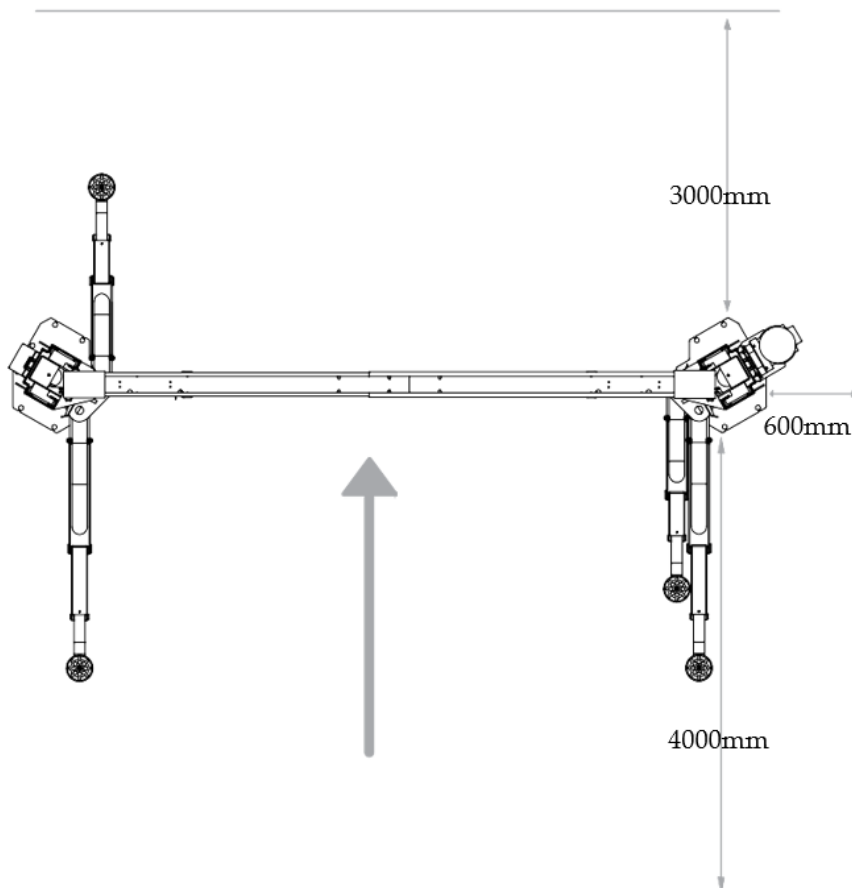
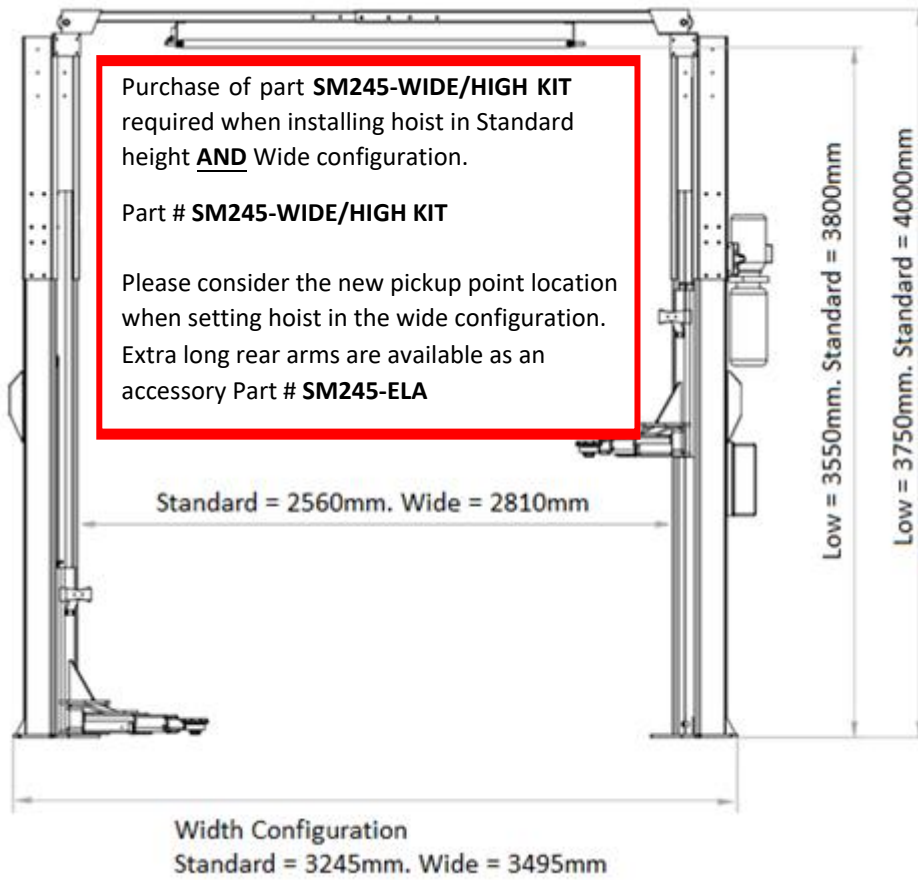

1. Required Tools

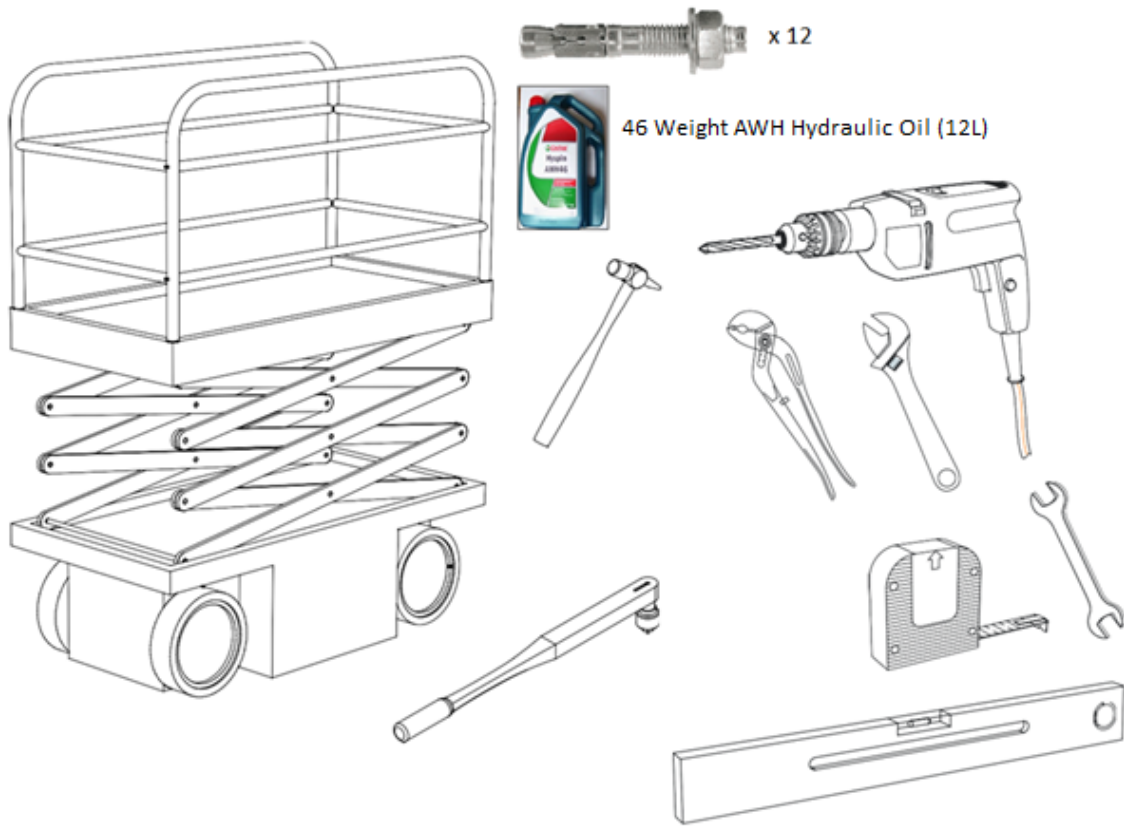

Figure 1

2. Place all components as shown and check supplied parts against packing list.

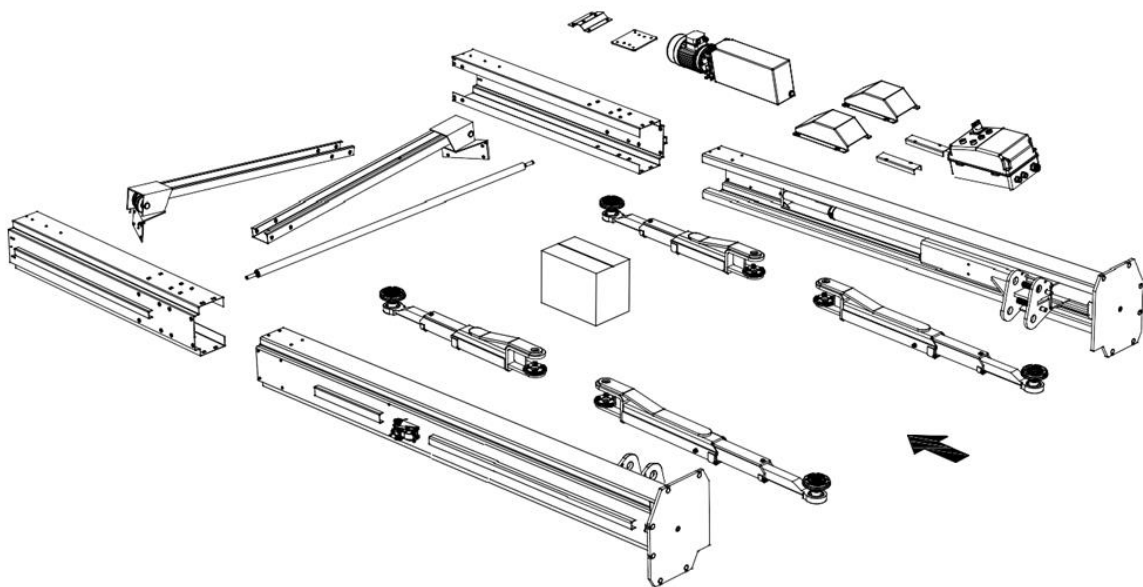

Figure 2

- Fit post extensions on posts in the appropriate height while posts are lying down. Torque for Allen key screws M10x16 is 46 Nm.

**NOTE!** The SM245 Hoist comes preconfigured for the **Standard** height setting. When possible, always install the hoist in the **Standard** height setting.

**NOTE!** Take care to fit the post extension shown on control post.

**NOTE!** The hoist arrives with the cables set for the **Standard** height and standard width configuration. If post extensions are fitted in **Standard** position the extra cable covers (Figure 3) must be fitted on both posts. (Not required in **Low** position)

**NOTE!** If post extensions are to be placed in the **Low** position (-250mm), cables must be moved upwards in the carriage to the position as shown on Figure 11 on page 10. This must be done before post is raised.

**NOTE!** If hoist is to be set in the wide position (+250mm), cables must be moved downwards in the carriage to the middle position as shown on Figure 11. This must be done before post is raised.

**NOTE!** If hoist is to be set in both Standard height and Wide (+250mm each way), cables must be removed from the hoist and replaced with the new cables in the kit part # **SM245-WIDE/HIGH KIT**. Cables are mounted in the carriage at the bottom position as shown on Figure 11. This must be done before the post is raised.

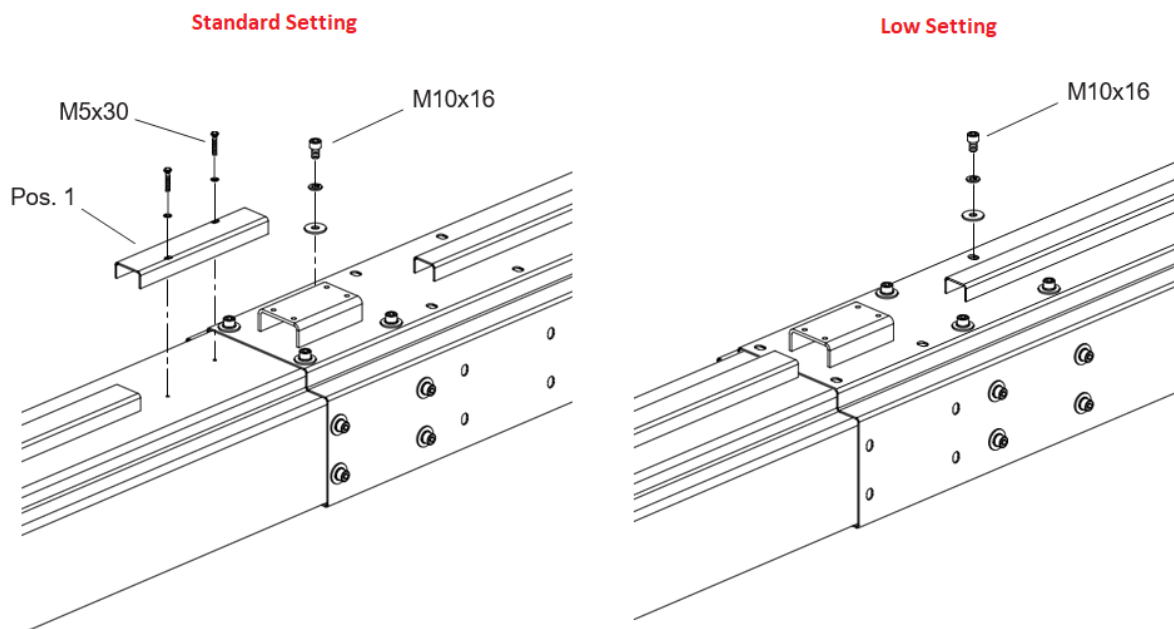

Figure 3

4. **NOTE!** The requirements of the local authorities concerning installation of hoists must always be respected

Mark out the bay and put a chalk line across the bay at the centre position of the hoist and mark the outside dimensions of the posts.

Raise posts by means of straps.

Position the posts over the chalk line using the marks to achieve the correct angle.

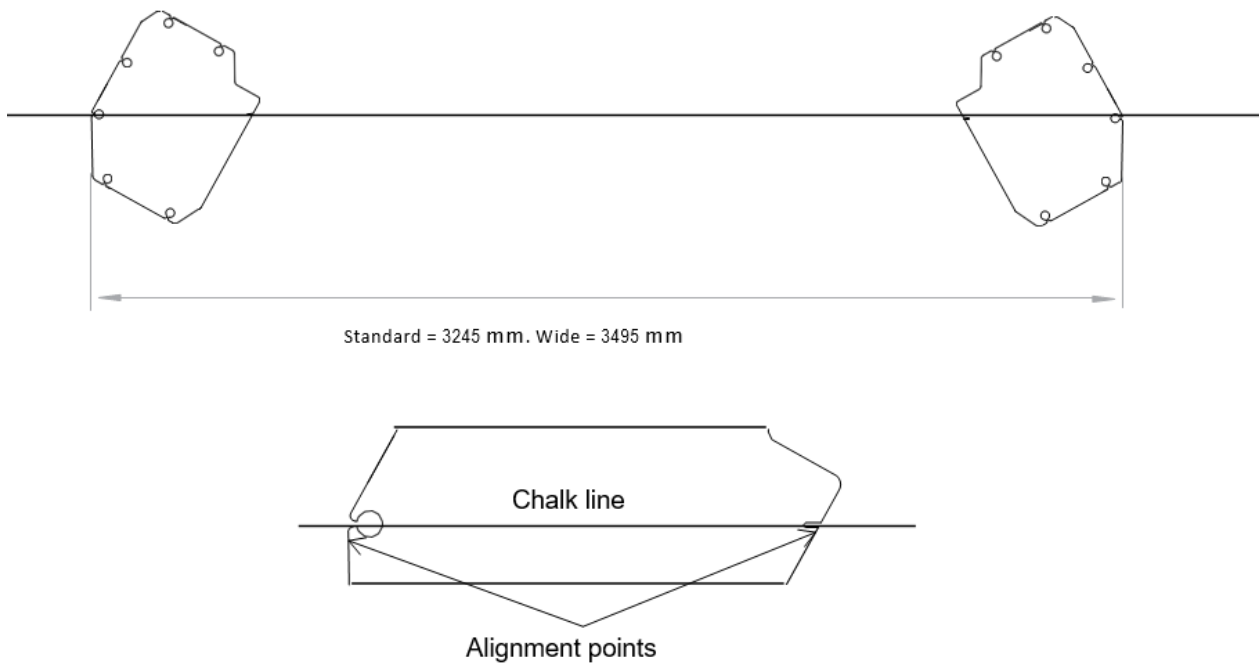

Figure 4

5. Drill holes for 2 anchor bolts in each post (to ensure that posts do not tilt during installation). Drill holes through base plate. Fasten posts by means of anchor bolts - do not tighten bolts yet as definitive adjustment of post position will take place later (see step 8).

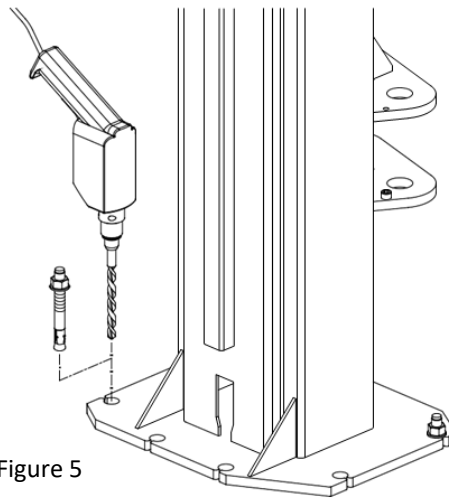

Figure 5

6. Assemble top brace assembly to suit the required setting.

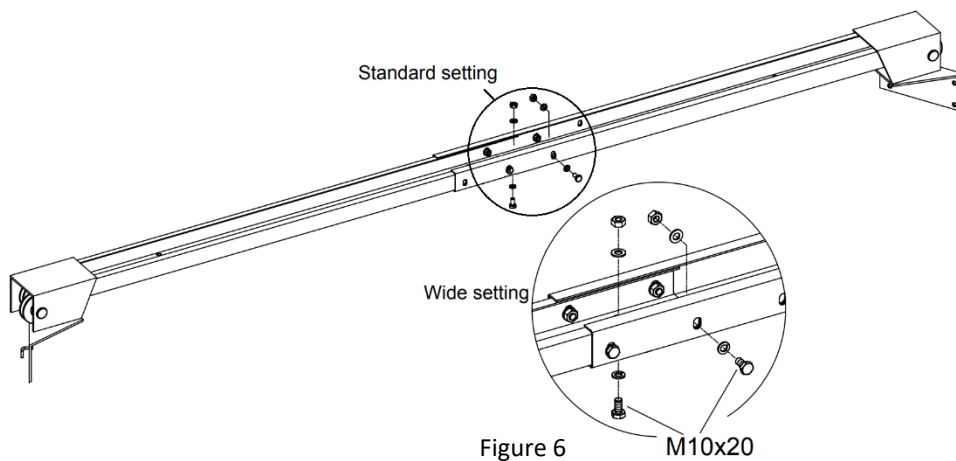

Figure 6

M10x20

7. Fit rod for top sensor limit switch.

**NOTE!** Take care that bracket with holes for top limit switch (item 1) is placed at control post as shown.

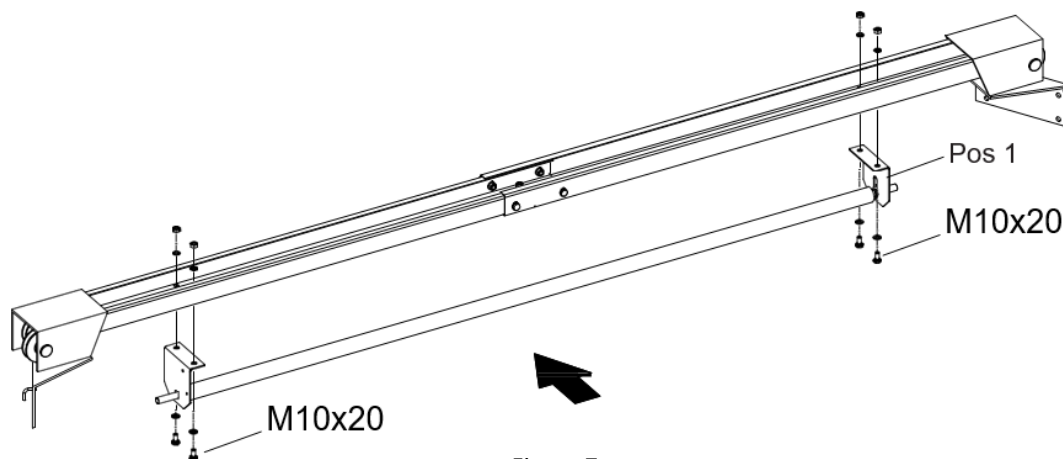

Figure 7



8. Raise the top brace and place on posts. The hooks on the mounting face will engage the post extension to support it.  
Adjust distance between posts if necessary. Fasten portal - tighten bolts.

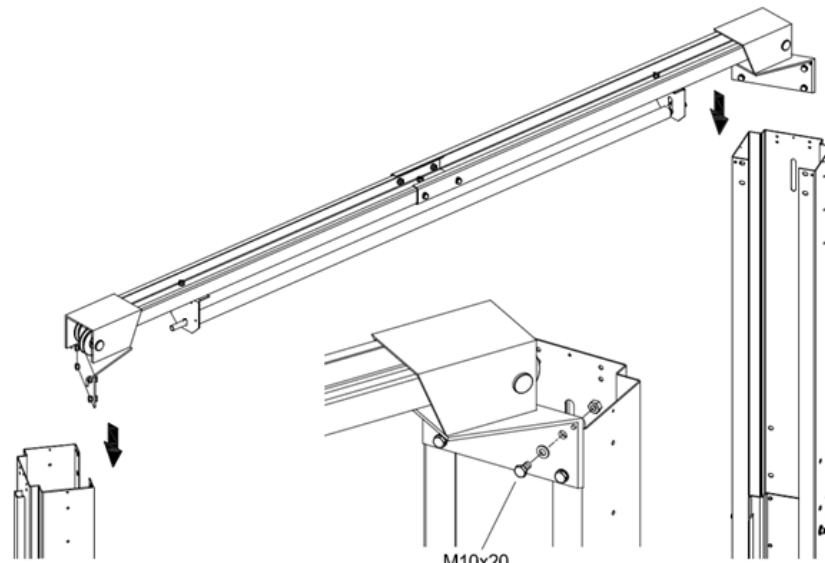
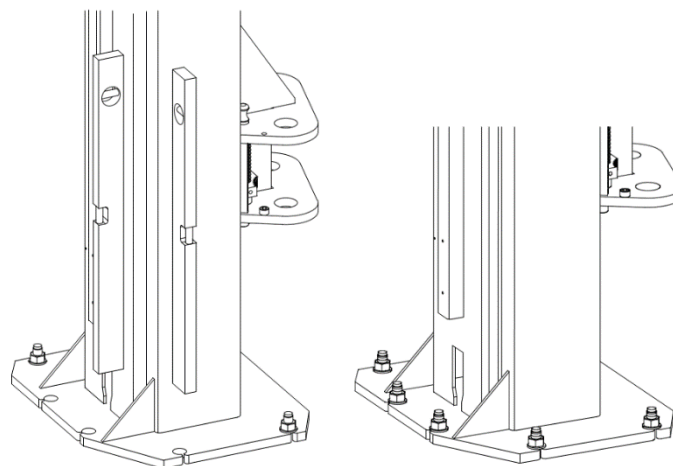

Figure 8

9. Check distance between posts and that posts are plumb - shim up if necessary.  
10. Drill holes through base plate for remaining expansion bolts. Tighten all expansion bolts. Torque for expansion bolts:

| Type of anchor | Torque |
|----------------|--------|
| Thru-bolt      | 240Nm  |
| STA bolt       | 150Nm  |



Figure

**NOTE!** Shim up baseplates so that posts are vertical. As much baseplate surface should be in contact with the floor as possible. Molnar recommends at least 50% surface or shim to floor contact, especially in the middle of the baseplate which must be in contact with the floor or shimmed.

11. Pull pre-fitted cables up through posts - above cable pulleys in portal and fasten them in carriage on opposite post.

**NOTE!** Cables are pre-fitted in carriages on the assumption that post extensions will be placed in **Standard** height (as shown on Figure 11).

If post extensions are to be placed in **Low** configuration (~250mm), cables must be moved up to the top mount in carriage as shown on Figure 11.

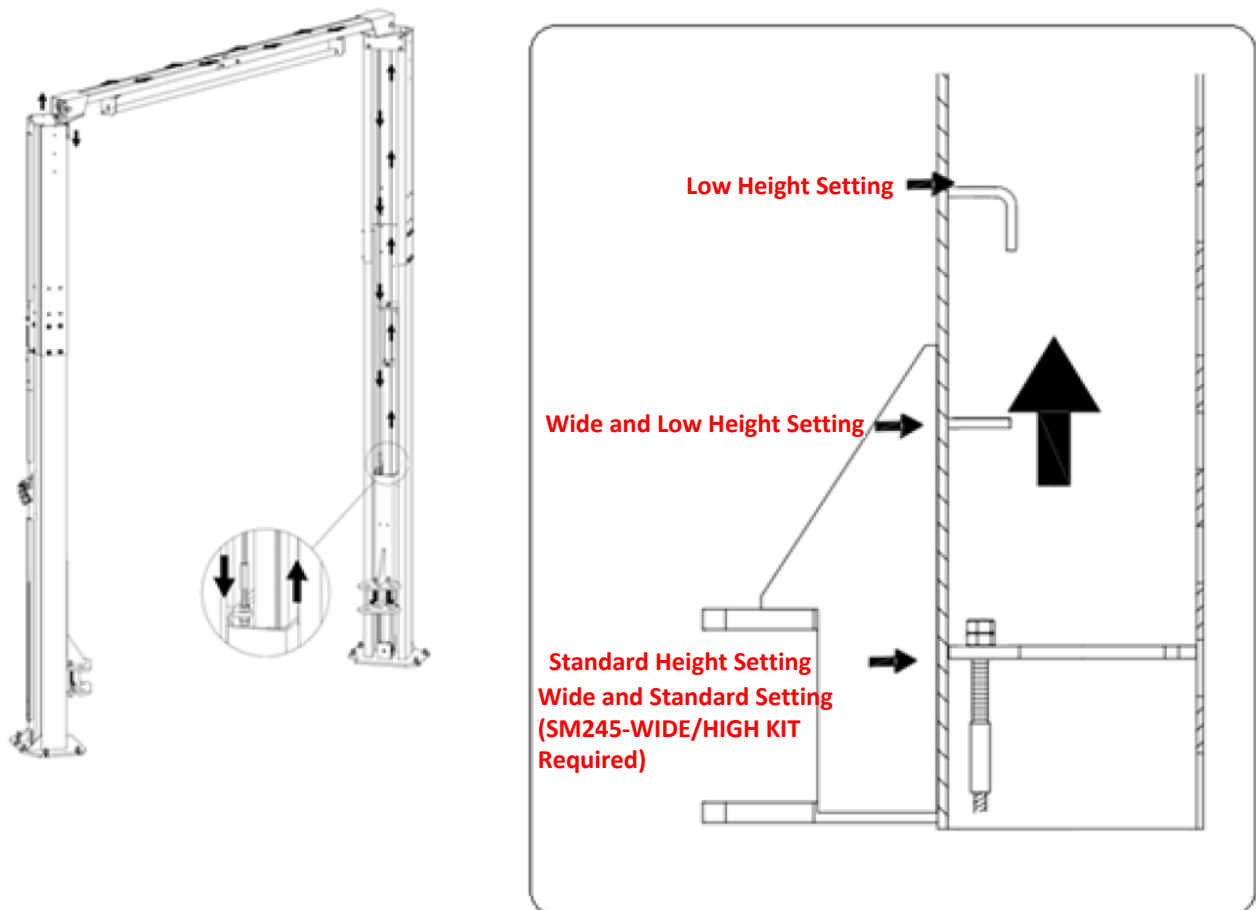

Figure 11

**NOTE!** If changing the cable setting position after the posts have been anchored:

- Crane required to lift carriage, lift up carriage and then rest on locks. (Lock install step 12)
- Undo cable nuts, take cable out of current setting position and then relocate to desired setting as shown in Figure 11 above.
- Check bottom of cylinder is still located in base plate locator hole.
- Firm but not overtighten bolts.

12. Install the Lock/solenoid on each post as shown in Figure 12 below.

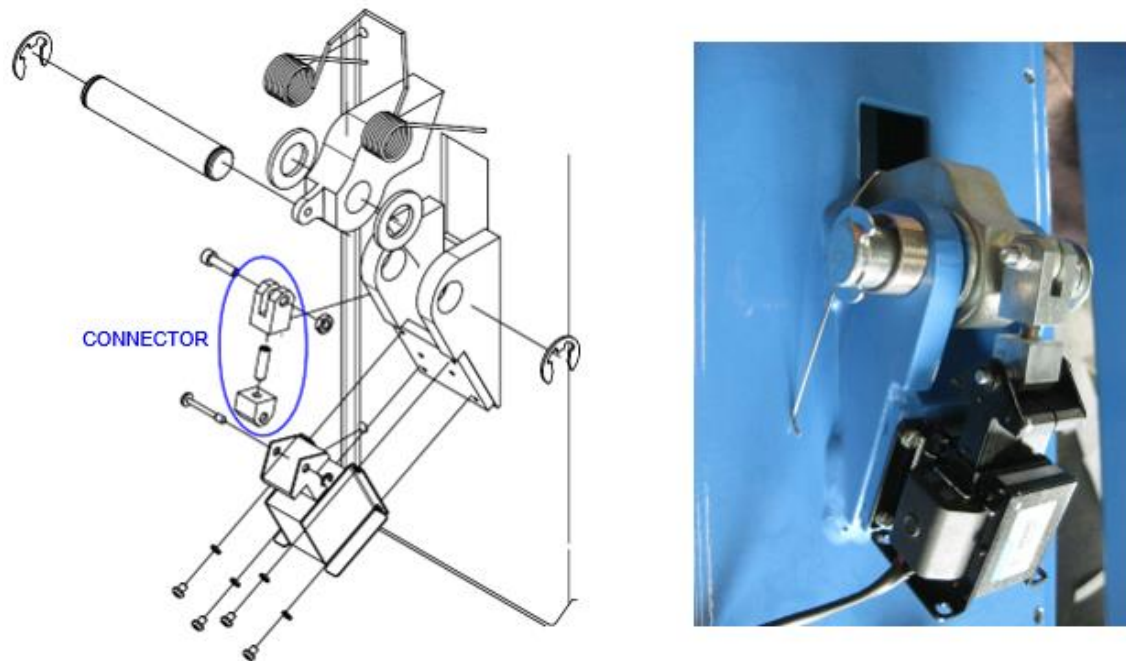
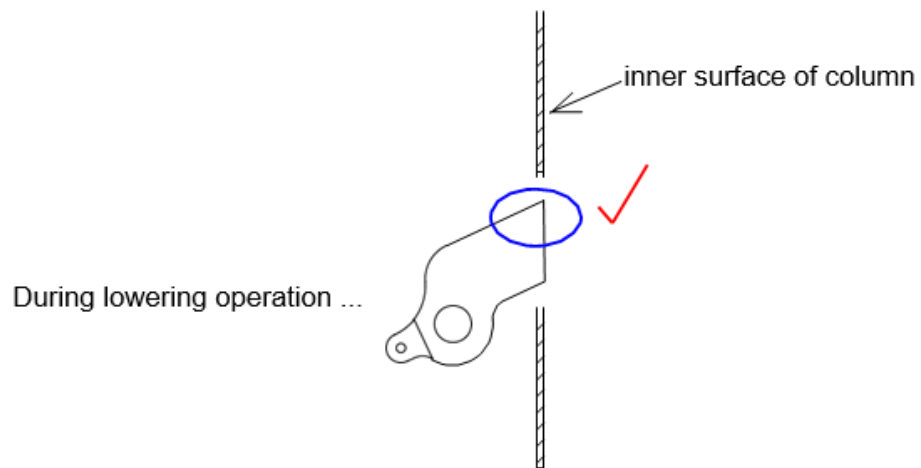

Figure 12

**NOTE!** If necessary please adjust the **CONNECTOR** to make sure that when solenoid acts - pulling the ratchet lock for lowering the hoist, the front end of ratchet lock does not exceed the inner surface of the column. Otherwise the ratchet lock may interfere the lowering of the hoist.



13. Fit control unit on control post.

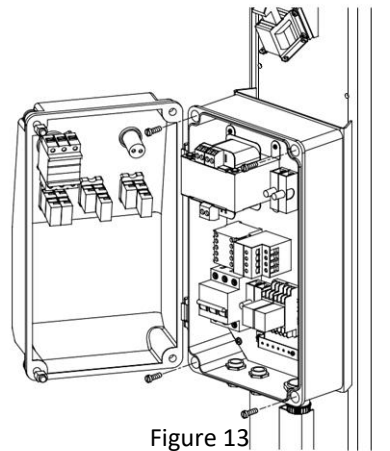

Figure 13

14. Pull cables from control unit as shown on Figure 14.

**NOTE!** It is important that cables are pulled in and out through the top of the channel at the top of post extensions (Figure 14).

**NOTE!** Be careful that wires are arranged in a way that they don't get caught on the locking mechanism. (Neat example shown in Figure 15.)

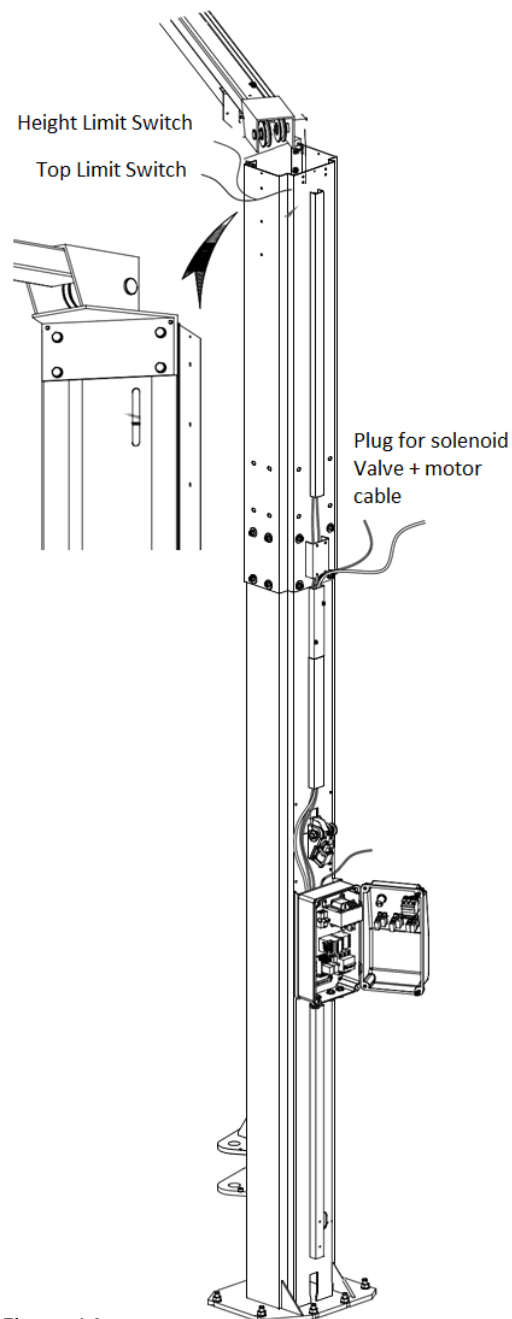

Figure 14

15. Connect safety solenoid wires on both post by means of 2-core cable.

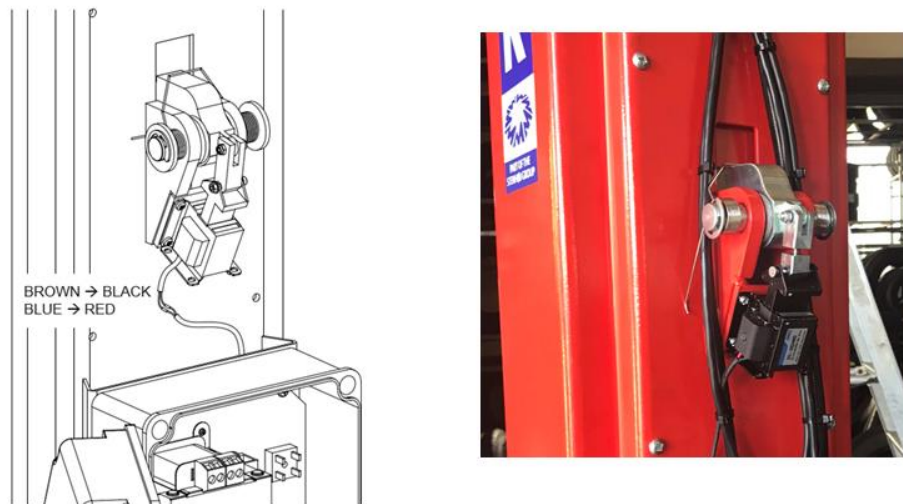

Figure 15

16. Fit top limit switch on the bracket as shown in Figure 16.

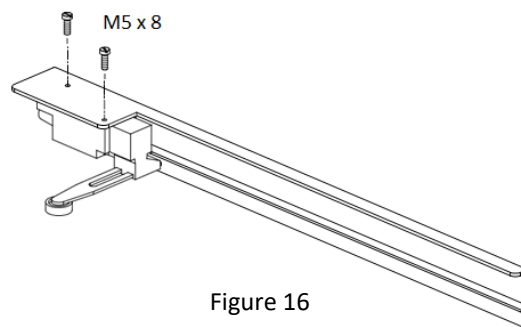

Figure 16

17. Fit bracket for top limit switch in control post.

**NOTE!** Short cable limit switch is for the top limit switch (control post), long cable for cross beam height limit switch.

**NOTE!** The top limit switch can be adjusted by sliding the bracket up/down. The position will differ depending on the hoist height setting. (**Low** or **Standard**)

**NOTE!** As a guide for estimating the top limit switch positioning, locate approx. 1800mm above top of the retracted piston rod.

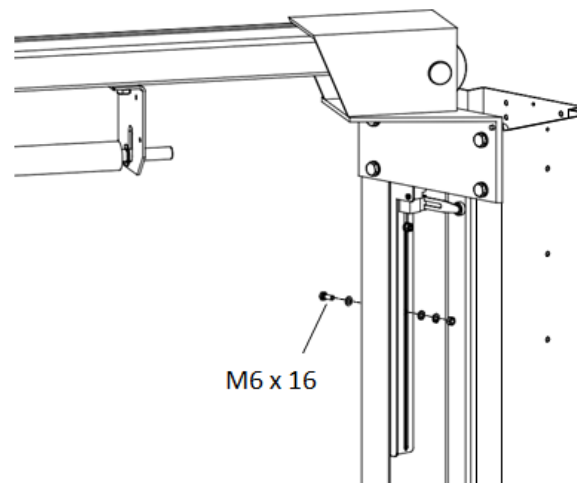

Figure 17

18. Fit height limit switch on bracket and connect this and top limit switch by means of 2-core cables from control unit.

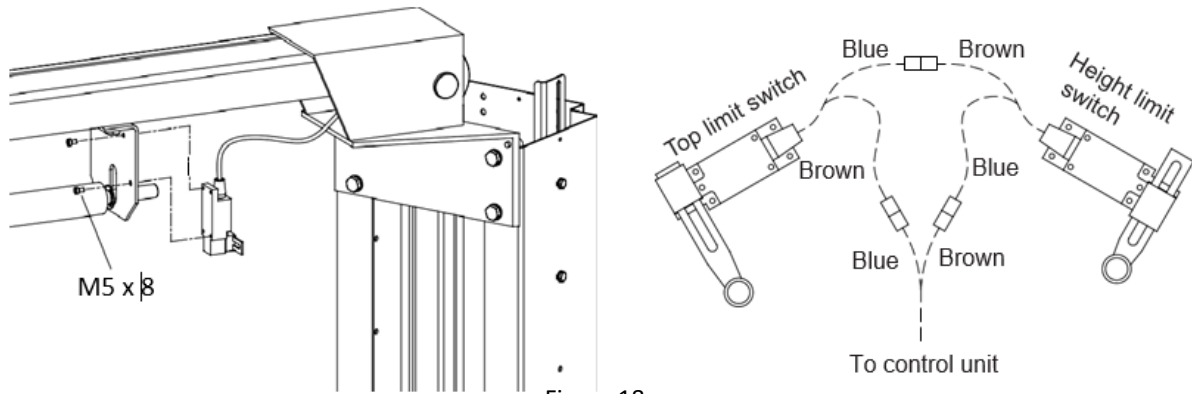

Figure 18

19. Pull hydraulic hoses as shown on control unit.

**NOTE!** It is important that the hydraulic hoses are pulled in and out through the position in top of post extensions in the same way as show for the cables on Figure 19.

**NOTE!** If installing the hoist in the **Low** configuration then ensure there is sufficient cable clearance at the top of the post extension to allow for the carriage to clear the cables. (prevent rubbing wear)

**NOTE!** If installing the hoist in the **Standard** height and **Wide** configurations, then use the hydraulic extension hose supplied.

Long hydraulic hose is to be pulled over top brace and down through cable covers on slave post.

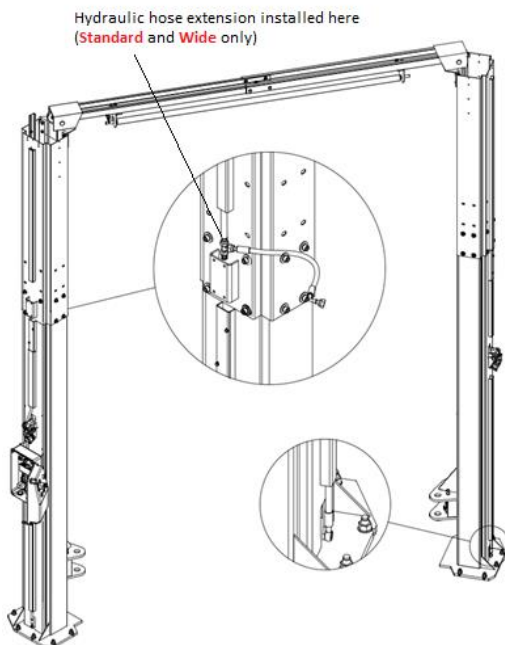

Allow for sufficient cable/hose clearance for the carriage, especially when hoist installed in **Low** Configuration. (Tie off to side with zip ties if necessary.)

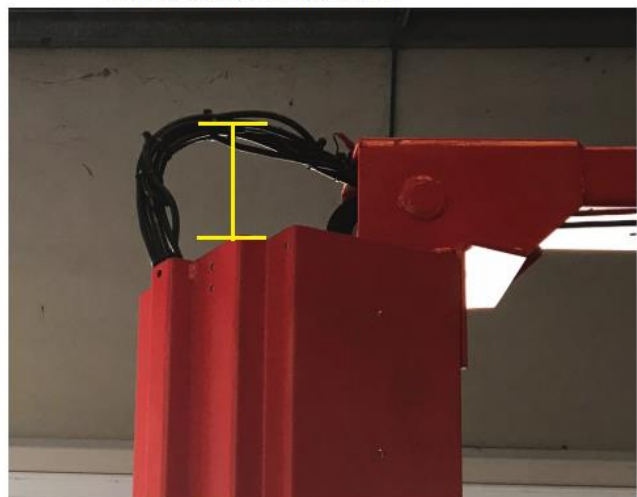

Figure 19

20. Fasten both hydraulic hoses on bottom of cylinder by means of banjo screw connection.  
**NOTE!** Confirm at the same time the cylinder is located in the hole on base plate.

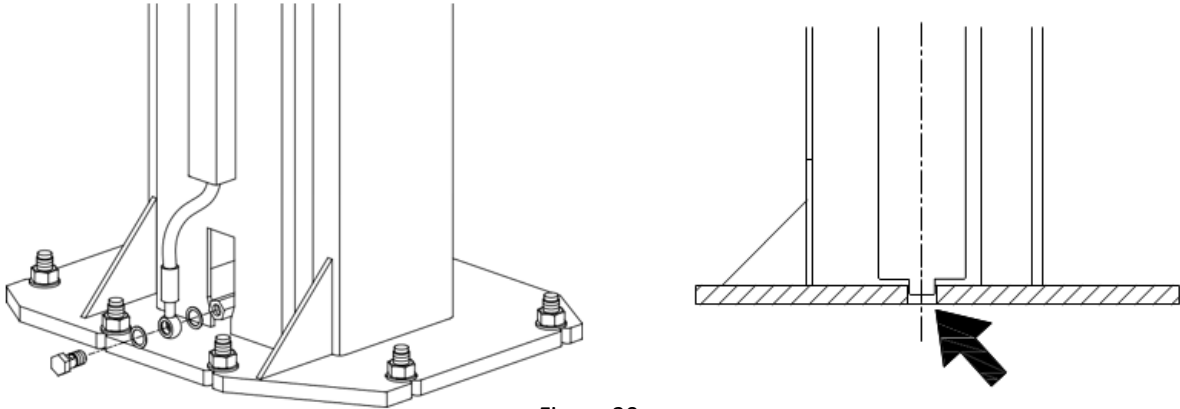

Figure 20

21. Fit the bracket for pump unit with vibration absorbers and fasten on post.

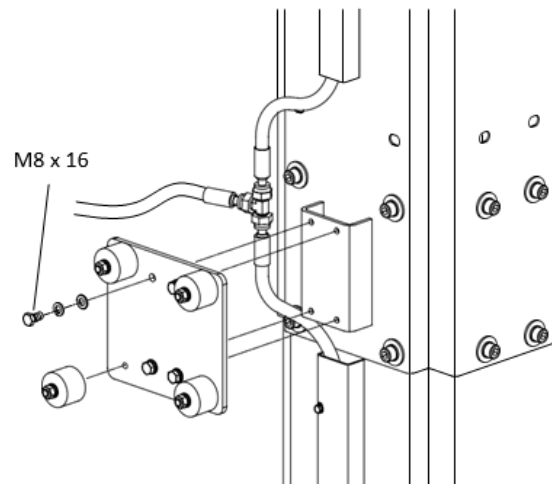

Figure 21

22. Fit the motor mounting plate on pump unit.

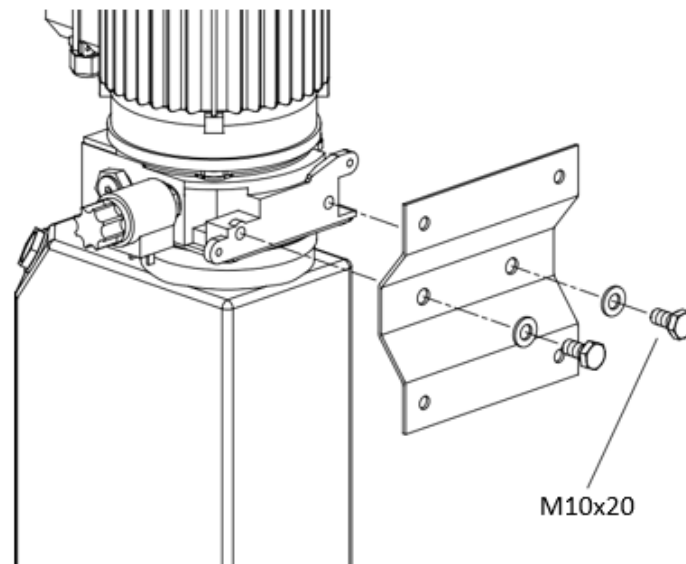

Figure 22

23. Fit the pump unit on post.

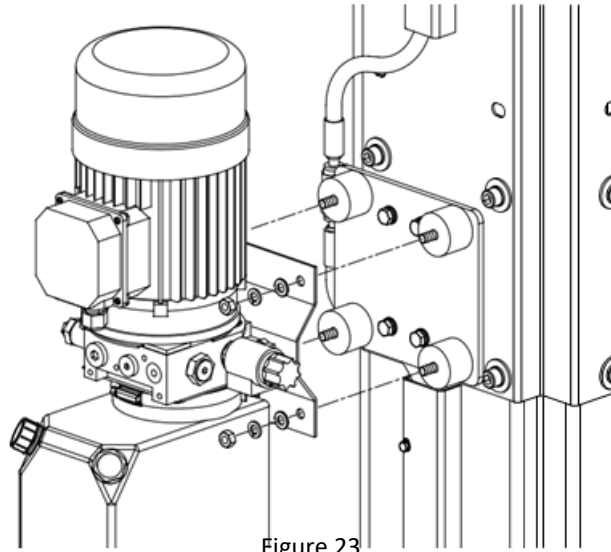

Figure 23

24. Fit short hydraulic hose on pump unit with fittings as shown.

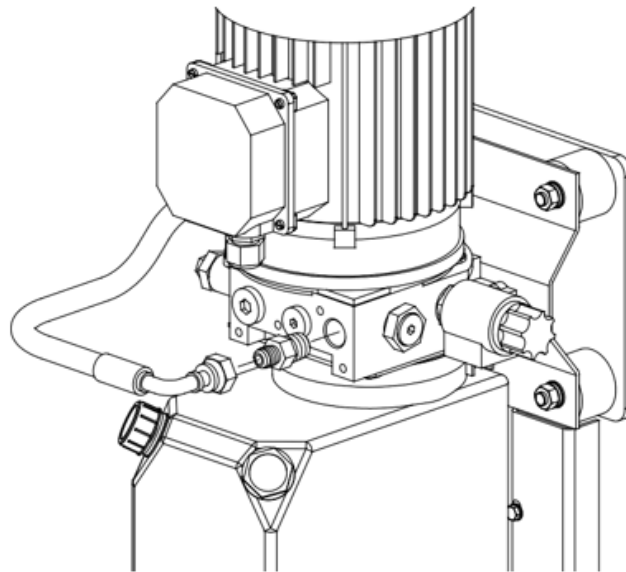

Figure 24

25. Fit 2-core cable for plug to solenoid valve.

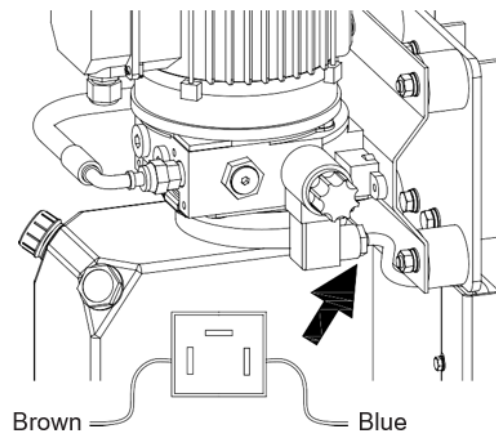

Figure 25



26. Fill the tank with hydraulic oil. (46 Weight AWH)

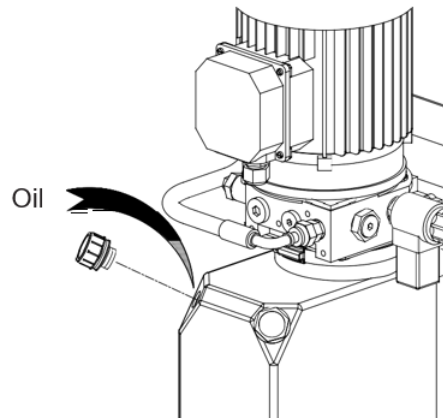

Figure 26

27. Fit motor cable on pump unit. For correct cable connection according to mains supply, see sketch.

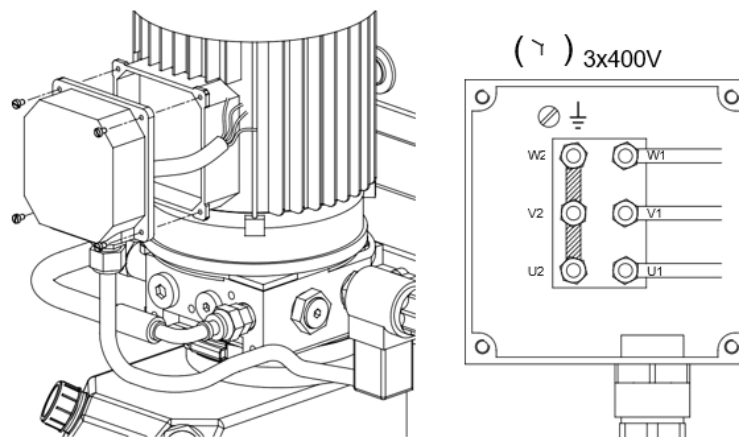

Figure 27

28. Connection to mains must be made by authorized electrician.  
Wiring diagram is part of the operation and maintenance instructions.

Check that electric motor is connected for correct voltage.

Turn main switch to "ON". Push UP-button. After a few seconds pump should start taking oil from oil tank. If not, pump is not running the right direction and 2 phases have to be interchanged in the mains connection.

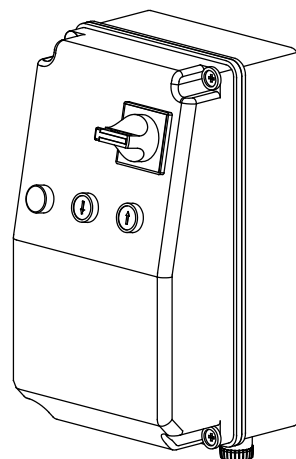

Figure 28

29. Raise hoist until safety lock clicks. Adjust cable to same distance in safety locks and re-tighten with a torque of 5 Nm.

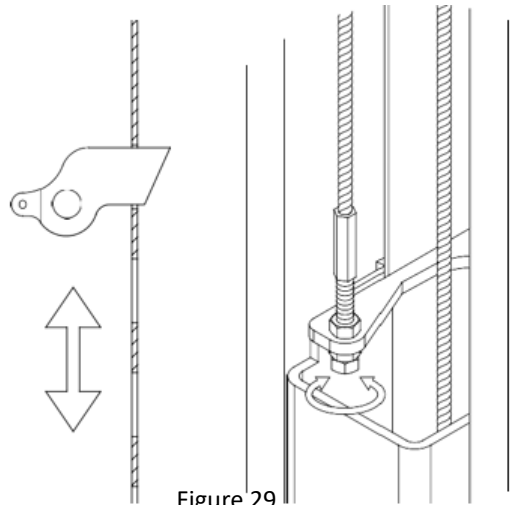

Figure 29

30. Apply grease to guiding edges on inner side of posts.

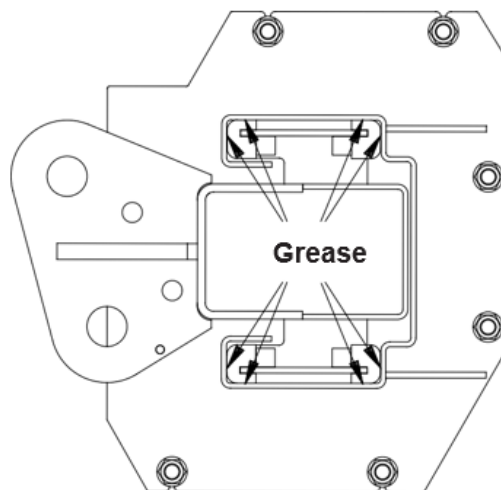

Figure 30

31. Raise the carriage approx. 300mm, fit arms and washers as shown.  
**NOTE!** Lubricate holes in carriages and washers before fitting.

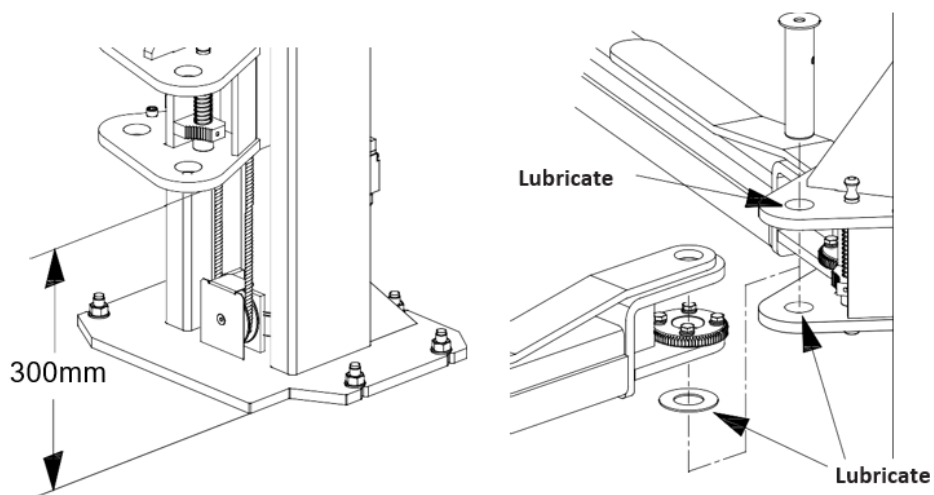

Figure 31

32. Fit retaining pins in axles.

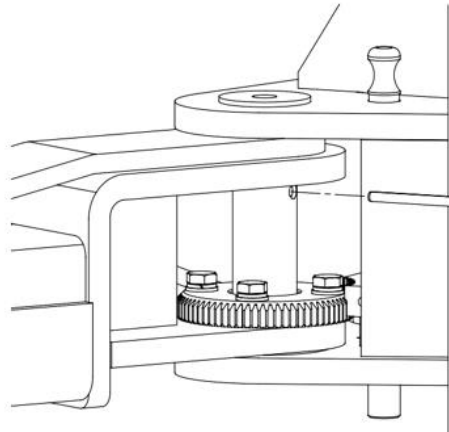

Figure 32

33. Raise hoist to adequate height and adjust arm locking device on all 4 arms. This can be done by turning each arm in an interval of 0 to 90° and check the engagement of the locking device 3 to 5 times on each arm.

Re-tighten the 4 screws on each arm.

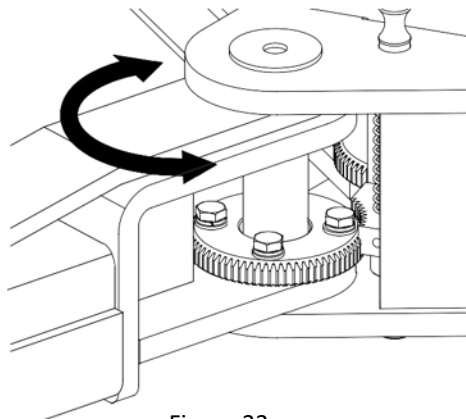

Figure 33

34. Bleed the hydraulic system:

Loosen bleeding screws in top of both cylinders.

Push UP-button until all the air is bleed out and only clean oil is present from both cylinders. Re-tighten bleeding screws. Lower again hoist to bottom position and fill up with oil (to max. mark on oil tank). **Ensure the supplied dowty washers are used with the bleed screws.**

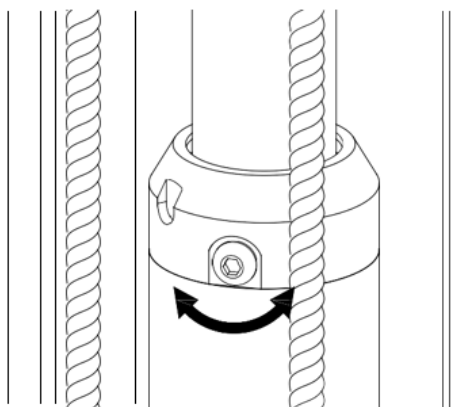

Figure 34

35. Check function of top limit switch and height limit stop.  
Adjust top limit switch to piston rod stroke = 1800 mm.



Figure 35

36. Fit the door stop and rubber covers on each post.

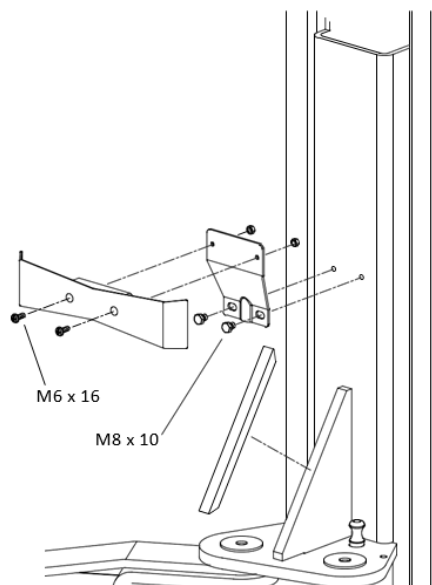

Figure 36

37. Fit the covers for the lock mechanisms on each post

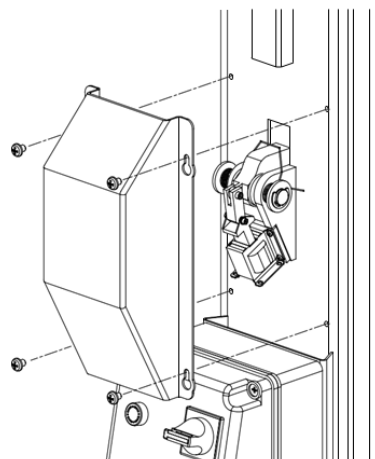

Figure 37

38. Install extension holder bracket at the base of each post



Figure 38

39. Bleed hoist one more time if necessary.
40. Clean hoist and test with vehicle. Give operator/owner thorough instructions.

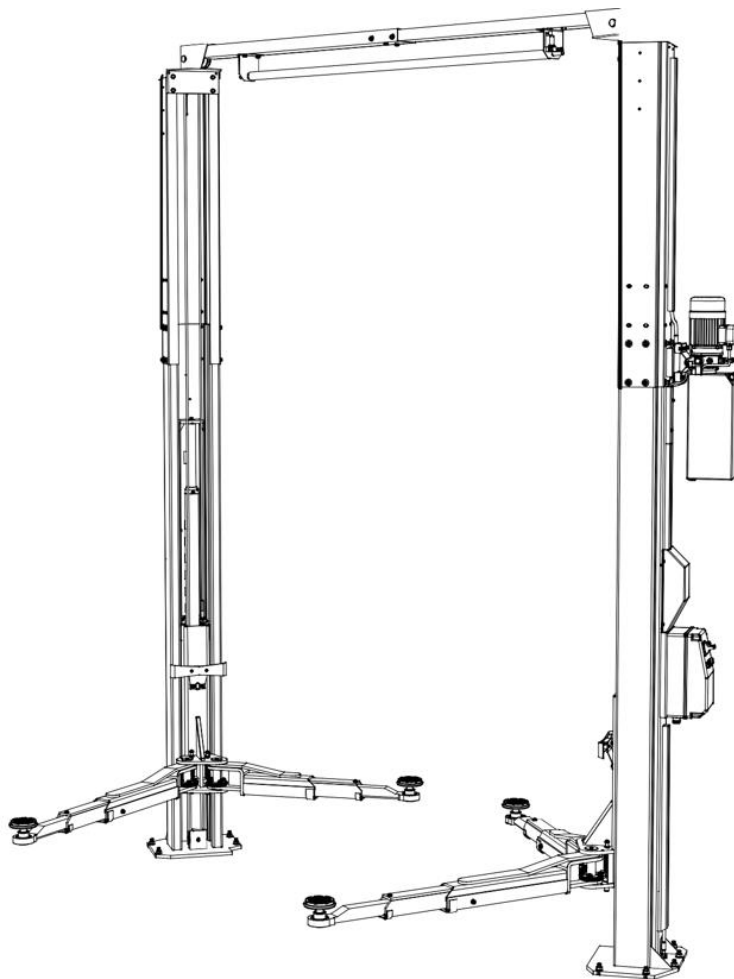

Figure 40

## Installer Checklist

Installer must complete (tick) the following list after installing this Molnar hoist:

- Legal clearances around hoist
- Floor is suitable and within manufactures specifications
- Wire ropes, pulleys and/or hoses are free of any damage
- Safety devices, limit switches and controls have been checked for correct operation
- Check the side and top arm stop bolts are installed, tightened and functioning by extending and testing both stages of all arms
- Hydraulic system checked and leak free at time of installation
- Hoist tested without and with load as per manufactures specifications
- Hoist has been lubricated and adjusted as per manufactures specifications
- Log book use has been explained to owner/operator and initial details completed
- The client representative has been shown and instructed in the correct operation and maintenance of the hoist

### Distributor (vendor)

Company \_\_\_\_\_

Branch \_\_\_\_\_

### Hoist

Installation Date \_\_\_\_\_

Model Number \_\_\_\_\_

Serial Number \_\_\_\_\_

### Hoist Owner

Business \_\_\_\_\_

Name \_\_\_\_\_

Position \_\_\_\_\_

Signature \_\_\_\_\_

### Installer Details

Name \_\_\_\_\_

Company \_\_\_\_\_

Signature \_\_\_\_\_

These records should be retained for administrative and warranty assistance.

Log books are available from Molnar Services or Molnar Hoists distributors.

Part Number: **8209001 - Hoist Log Book Kit**

## Molnar SM245

### Lowering Valve Adjustment

(For 3 phase powerpacks with hoist serial number 2G4D4285 and greater)

The SM245 lowering speed can be adjusted by carefully adjusting the lowering valve shown in the image below. The valve turned completely prevents the hoist from descending, turning back from this position adjusts the lowering speed.

*AS/NZS 1418.9 states that the recommend rate of ascent or descent for the SM245 is 0.04 m/s. The rate of descent of a vehicle hoist shall not exceed 0.1 m/s under any circumstance.*



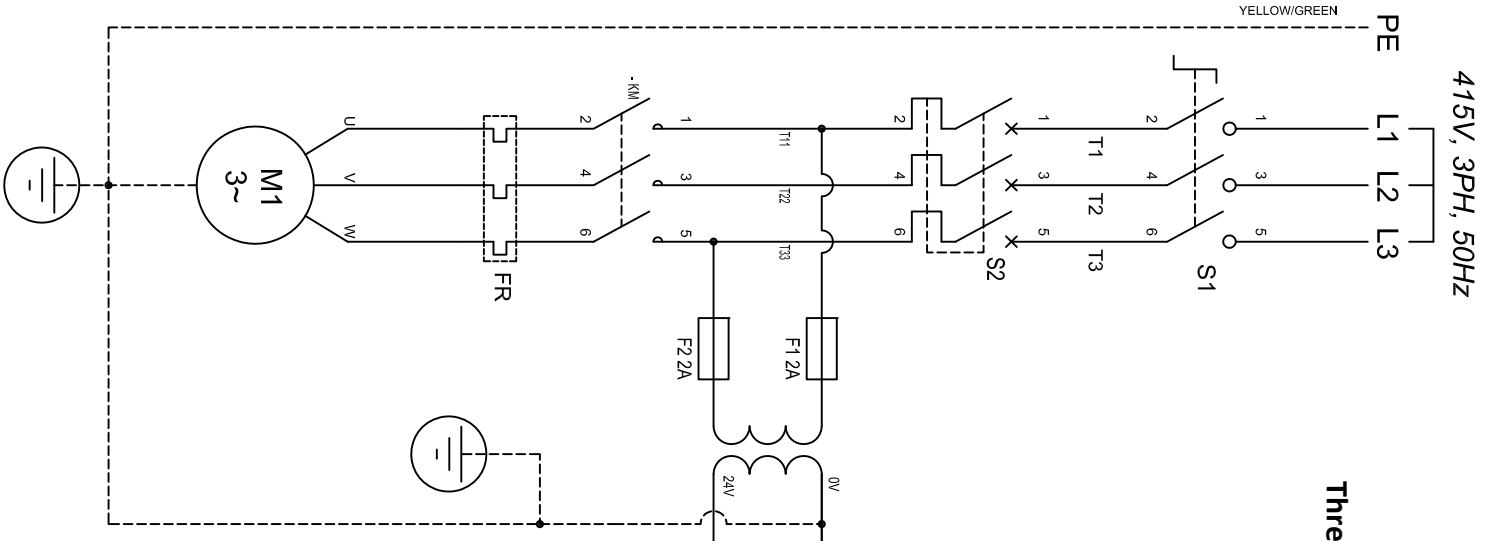

Three Phase Wiring Diagram (From Serial Number 2G4D4989)

\*Input current supply for 3 phase no less than 10A, for single phase no less than 20A

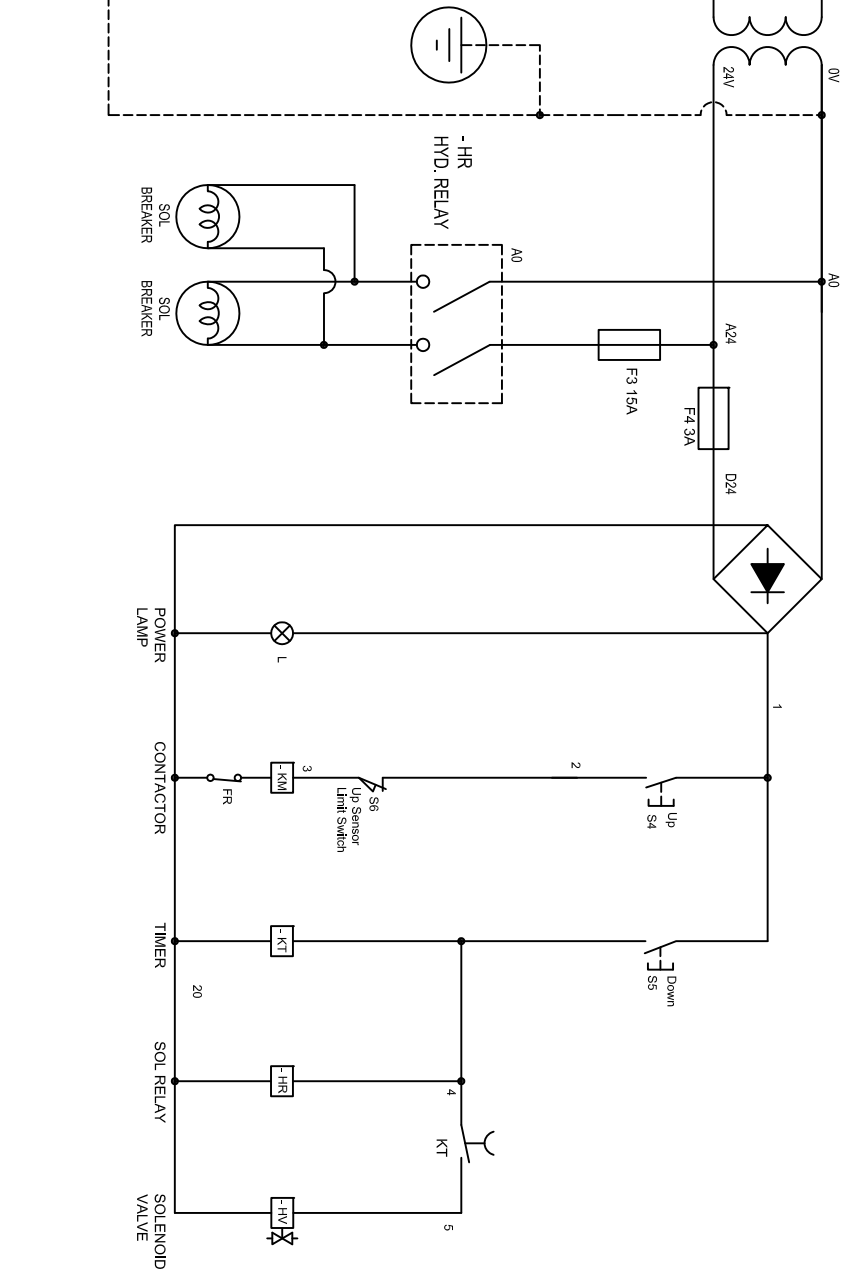



240V, 1PH, 50HZ

Single Phase Wiring Diagram (From Serial Number 2G4D4989)

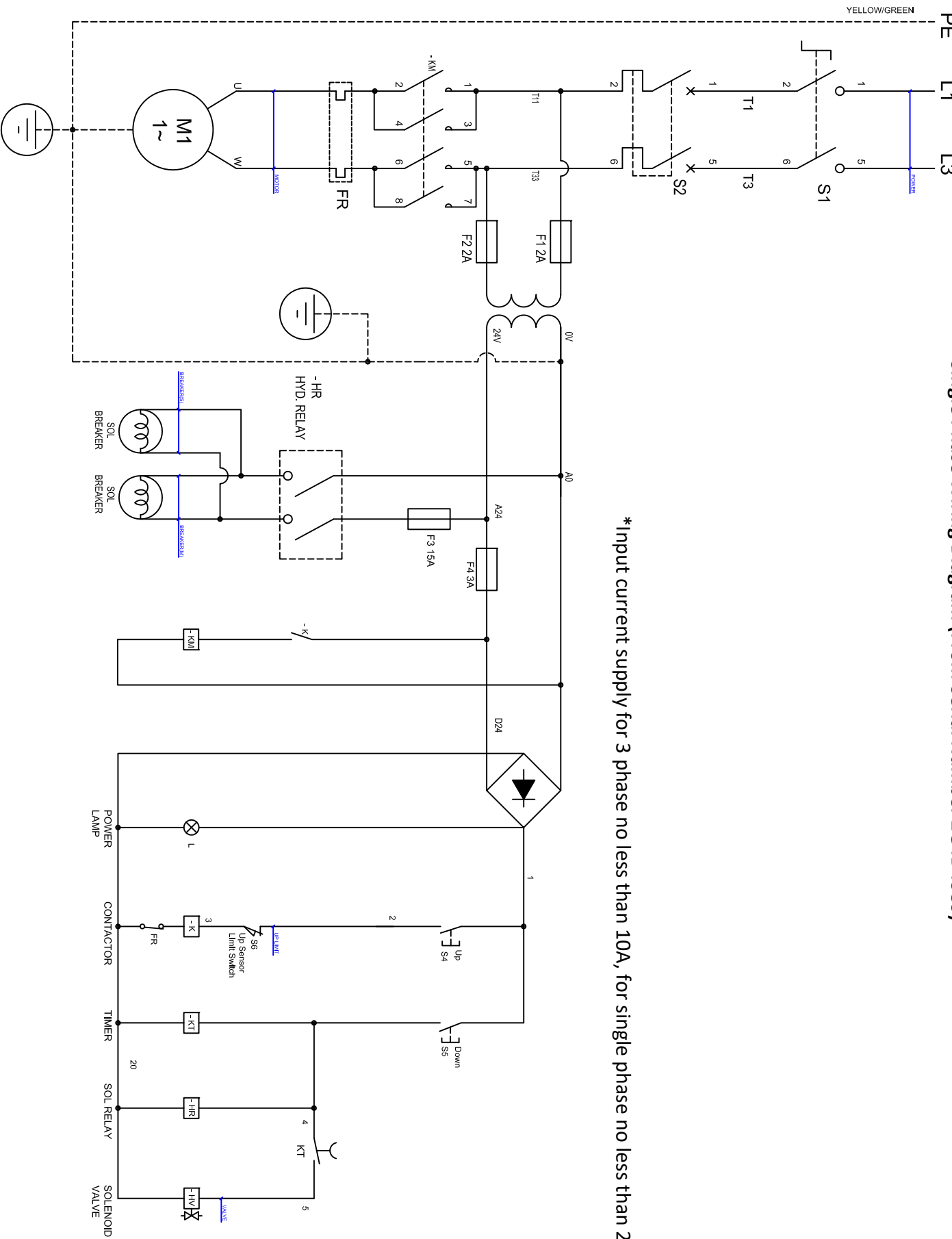

\*Input current supply for 3 phase no less than 10A, for single phase no less than 20A



Address: 3 Graham Street  
Export Park  
South Australia 5950

Ph: **+61 (08) 8234 3611**

Fax: **+61 (08) 8234 4322**

Email: [sales@molnarhoists.com.au](mailto:sales@molnarhoists.com.au)

Web: [www.molnarhoists.com.au](http://www.molnarhoists.com.au)