



*Makers of the famous
TWO-POST AND FOUR-POST
HOISTS & ACCESSORIES*

MOLNAR ENGINEERING PTY. LTD.

FOUR POST HOIST

PARTS IDENTIFICATION MANUAL

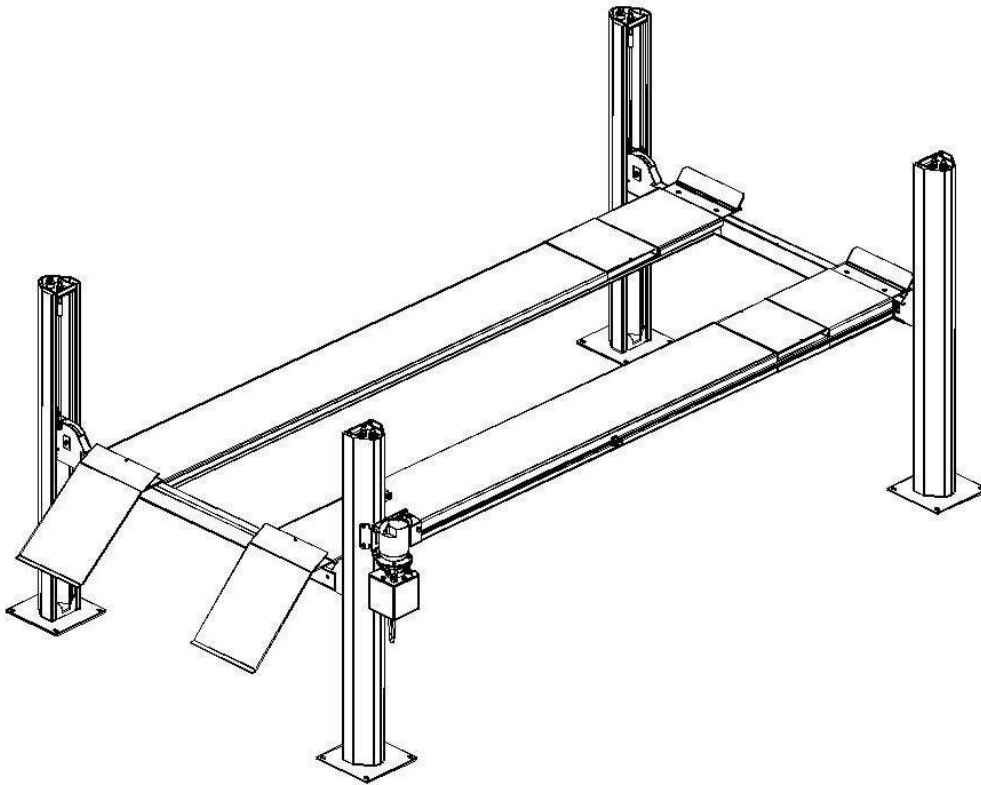

MODELS -

4488 S
4488 SA
4488 W
4488 WA
4488 D

Contents

Home Page	3
Cable and Pulley Layout	4
Cable Bill of Materials	5
Transverse Beam – Control End Page 1	6
Transverse Beam – Control End Bill of Materials 1.....	7
Transverse Beam – Control End Page 2	8
Transverse Beam – Control End Bill of Materials 2.....	9
Transverse Beam – Non Control End Page 1	10
Transverse Beam – Non Control End Bill of Materials 1	11
Transverse Beam – Non Control End Page 2	12
Transverse Beam – Non Control End Bill of Materials 2	13
Cylinder Assembly.....	14
Cylinder Assembly Bill of Materials.....	15
Post Assembly	16
Post Assembly Bill of Materials.....	17
Power Pack Assembly	18
Power Pack Assembly Bill of Materials	19
Left Hand Platform.....	20
Left Hand Platform Bill of Materials	21
Right Hand Platform.....	22
Right Hand Platform Bill of Materials	23
Double Pulley Assembly.....	24
Double Pulley Assembly Bill of Materials.....	25
Single Pulley Assembly.....	26
Single Pulley Assembly Bill of Materials.....	27
Stickers Bill of Materials.....	28
Optional Jacking Beam.....	29
Optional Jack Stand.....	30

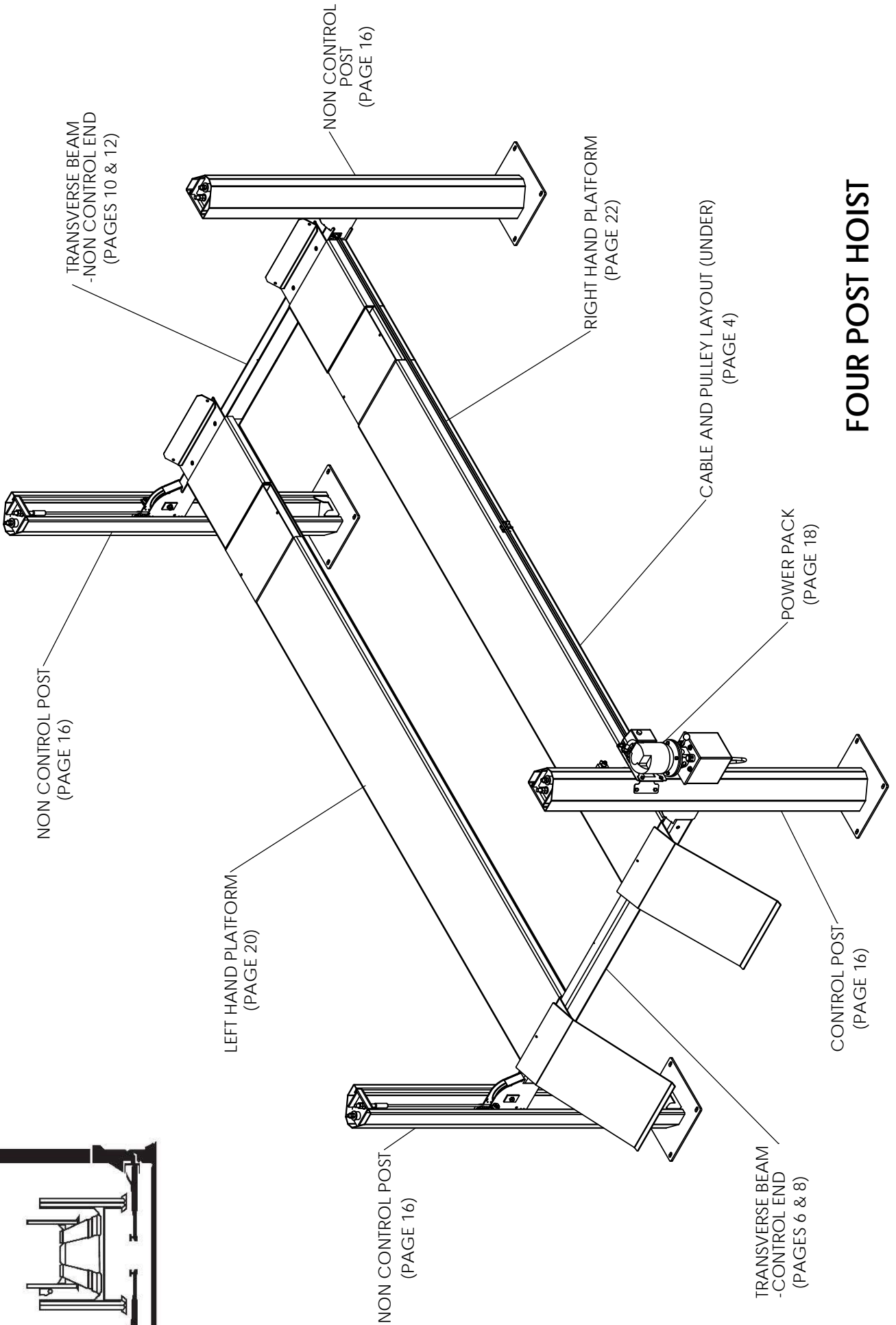
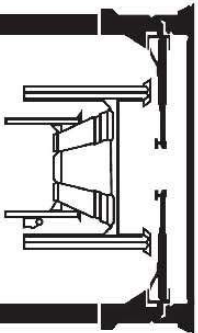

FOUR POST HOIST

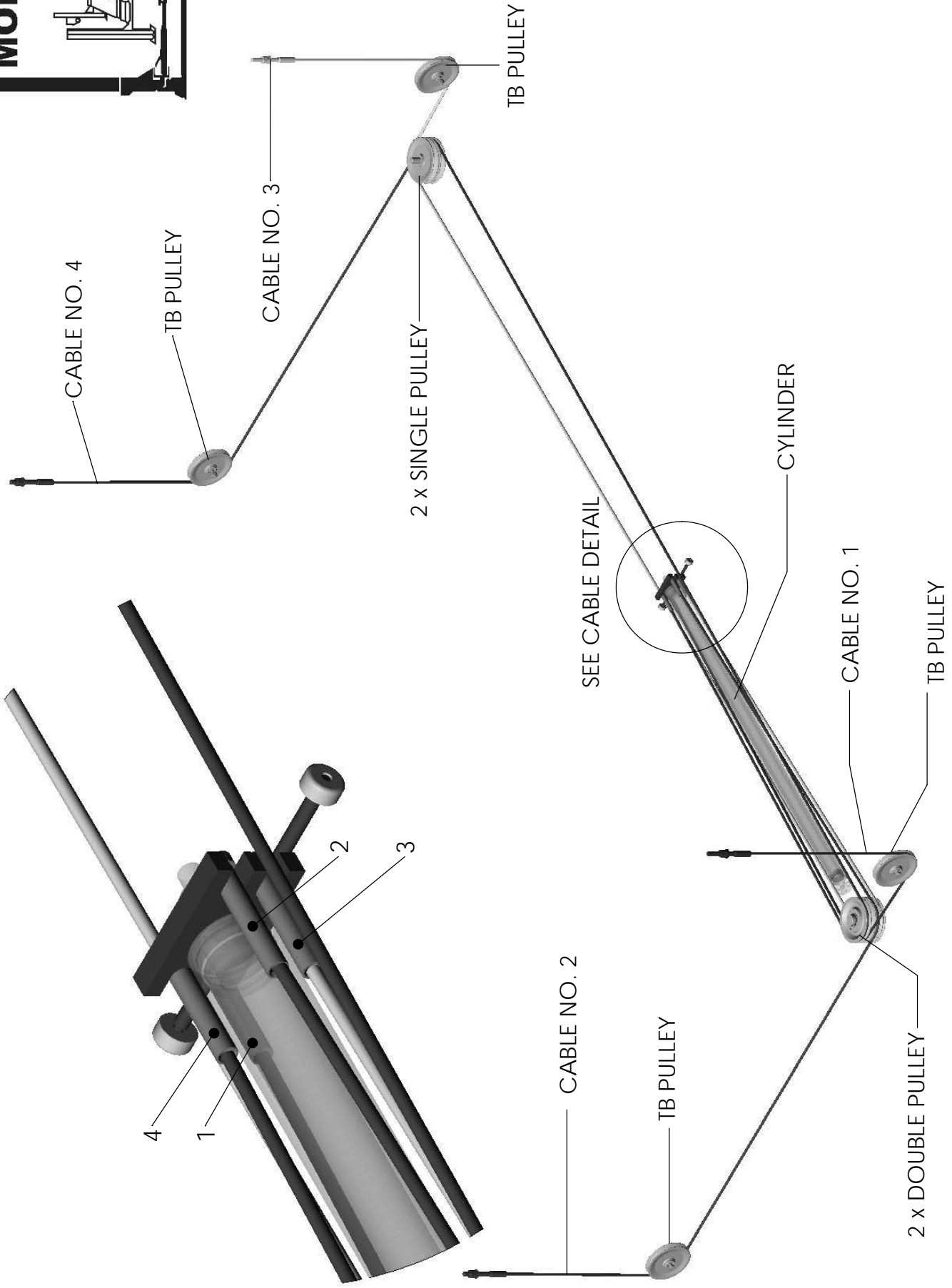
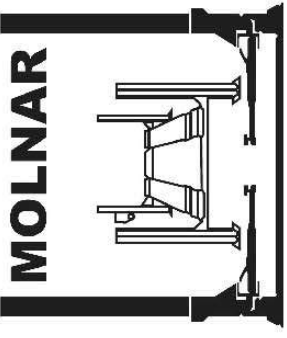

FOUR POST HOIST - CABLE AND PULLEY LAYOUT

CABLES

MODELS 4488S & 4488W (2340mm WIDTH BETWEEN POSTS)

ITEM #	PART DESCRIPTION	SPARE PART #
	CABLE (SET OF FOUR)	8045-000-4T
1	CABLE NO.1 (4430mm)	8045-609-4T
2	CABLE NO.2 (5880mm)	8045-610-4T
3	CABLE NO.3 (9060mm)	8045-611-4T
4	CABLE NO.4 (10510mm)	8045-612-4T

MODELS 4488SA & 4488WA (2700mm WIDTH BETWEEN POSTS)

ITEM #	PART DESCRIPTION	SPARE PART #
	CABLE (SET OF FOUR)	8045-000-4TA
1	CABLE NO.1 (4690mm)	8045-609-4TA
2	CABLE NO.2 (6240mm)	8045-610-4TA
3	CABLE NO.3 (9320mm)	8045-611-4TA
4	CABLE NO.4 (10870mm)	8045-612-4TA

MODELS 4488D - PLATFORM LENGTH 4000mm (2340mm WIDTH BETWEEN POSTS)

ITEM #	PART DESCRIPTION	SPARE PART #
	CABLE (SET OF FOUR)	8045-000-4TD
1	CABLE NO.1 (4430mm)	8045-609-4TD
2	CABLE NO.2 (5880mm)	8045-610-4TD
3	CABLE NO.3 (8480mm)	8045-611-4TD
4	CABLE NO.4 (9930mm)	8045-612-4TD

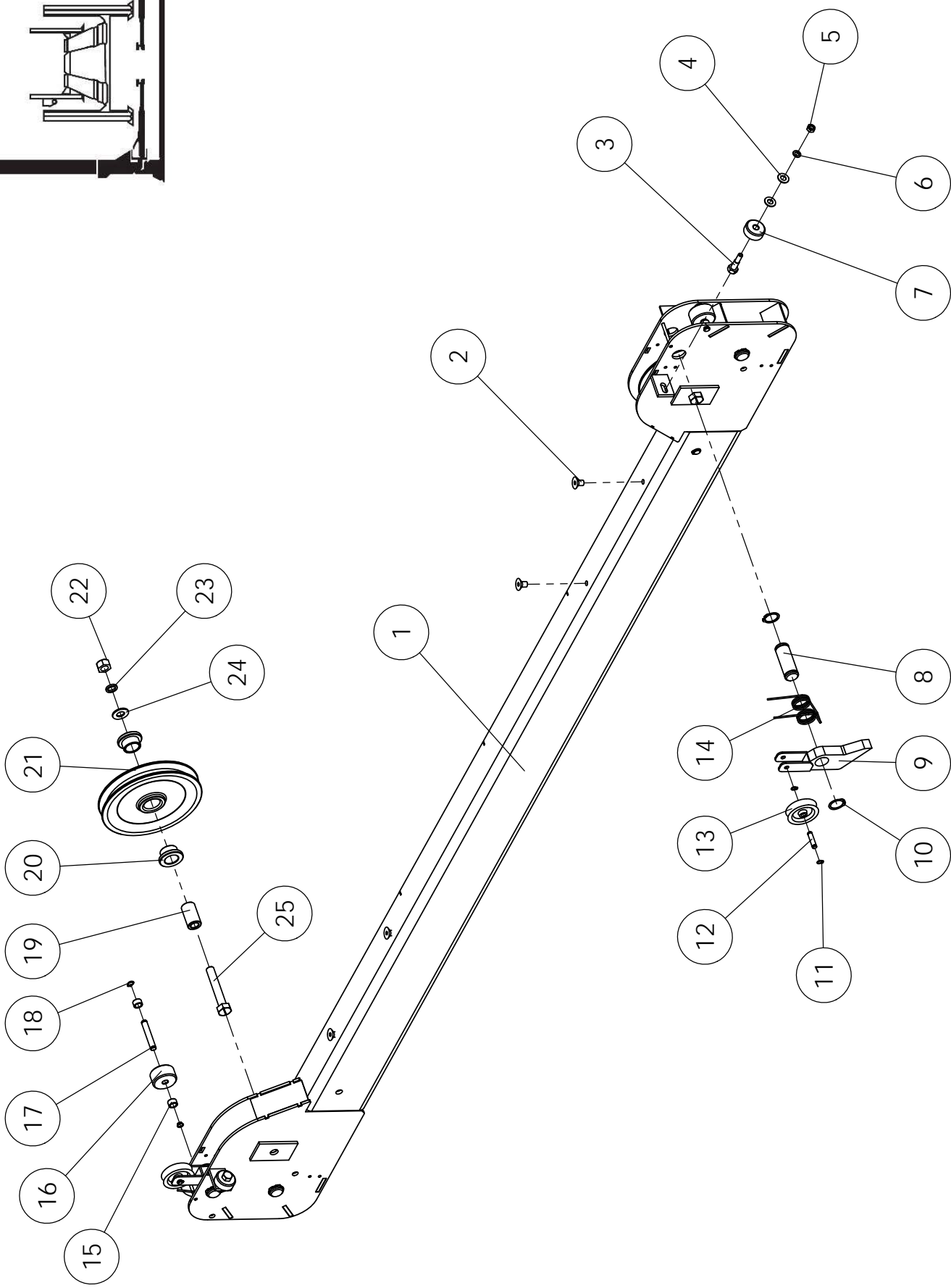
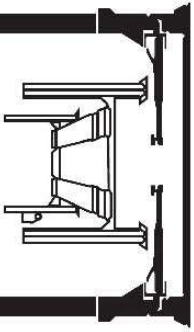

TRANSVERSE BEAM-CONTROL END

TRANSVERSE BEAM-CONTROL END

ITEM #	PART DESCRIPTION	SPARE PART #
1	TRANSVERSE BEAM-CONTROL END	4488S/W-TB-12A
	TRANSVERSE BEAM-CONTROL END A SERIES	4488SA/WA-TB-12A
2	SCREW COUNTERSUNK HIGH TENSILE M10X16mm	4488-TB-38
3	BOLT SHOULDER	4488S/W-TB-30
4	WASHER FLAT M10	4488S/W-TB-28
5	NUT M8	4488S/W-TB-26
6	WASHER SPRING M8	4488S/W-TB-27
7	ROLLER TRANSVERSE BEAM ADJUSTABLE GUIDE	4488-TB-29
8	PIN SAFETY PAWL MANUAL	4488-TB-32
9	PAWL SAFETY AUTOMATIC	4488-TB-34
10	CIRCLIP 25mm (4 PER ASSEMBLY)	4488-TB-31
11	CIRCLIP 8mm (2 PER ASSEMBLY)	4488-TB-35
12	PIN PULLEY SAFETY PAWL AUTOMATIC	4488-TB-36
13	PULLEY AUTOMATIC SAFETY PAWL (NYLON)	4488-TB-37
14	SPRING SAFETY PAWL	4488-TB-33
15	SPACER END ROLLER	4488-TB-23
16	ROLLER TRANSVERSE BEAM END	4488-TB-25
17	PIN END ROLLER	4488-TB-24
18	CIRCLIP 10mm (12 PER ASSEMBLY)	4488-TB-22
19	BUSH STEEL PULLEY	4488-TB-16
20	BUSH TRANSVERSE BEAM (2 PER PULLEY)	4488-TB-17
21	PULLEY TRANSVERSE BEAM (INCLUDES BUSHES)	4488-TB-18
22	NUT 9/16" UNF	4488-TB-21
23	WASHER SPRING 9/16"	4488-TB-20
24	WASHER FLAT 9/16"	4488-TB-19
25	BOLT HIGH TENSILE 9/16"X3 1/2" UNF	4488-TB-15

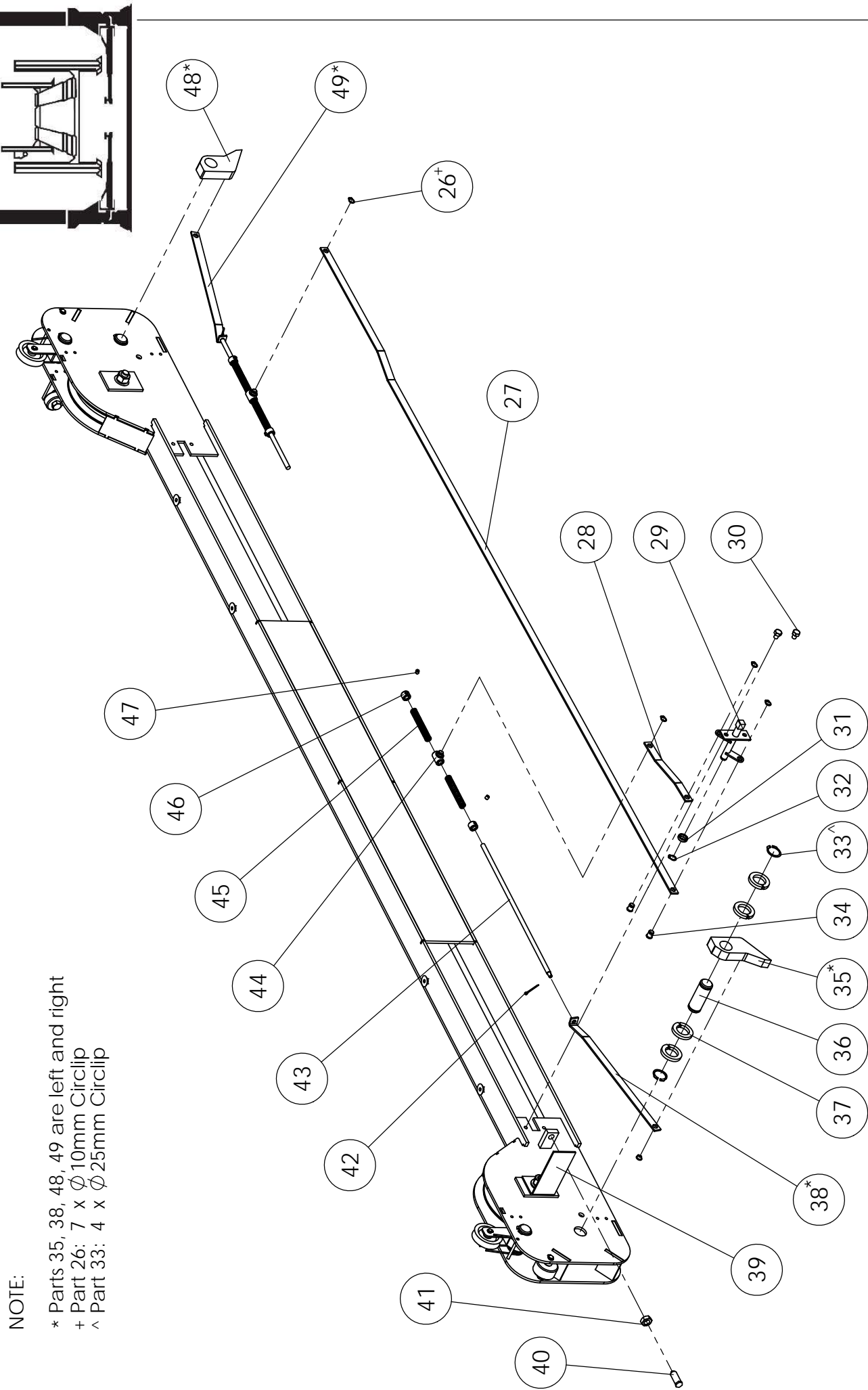

NOTE:

- * Parts 35, 38, 48, 49 are left and right
- + Part 26: 7 x Ø 10mm Circlip
- ^ Part 33: 4 x Ø 25mm Circlip

TRANSVERSE BEAM-CONTROL END

ITEM #	PART DESCRIPTION	SPARE PART #
26	CIRCLIP 10mm (12 PER ASSEMBLY)	4488-TB-22
27	LINKAGE LONG (STANDARD HOIST 2340mm WIDE)	4488-TB-42
	LINKAGE LONG (A SERIES HOIST 2700mm WIDE)	4488-TB-42A
28	LINKAGE SHORT TRANSVERSE BEAM	4488-TB-41
29	ACTIVATING BRACKET TRANSVERSE BEAM	4488-TB-55
30	BOLT 5/16"X1/2" WHITWORTH	4488-TB-56
31	SPACER ACTIVATING BRACKET	4488-TB-57
32	CIRCLIP 12mm	4488-TB-39
33	CIRCLIP 25mm (4 PER ASSEMBLY)	4488-TB-31
34	PIN SAFETY	4488-TB-40
35	PAWL SAFETY MANUAL LOCKING (RIGHT)	4488-TB-46
36	PIN SAFETY PAWL MANUAL	4488-TB-32
37	SPACER SAFETY PAWL MANUAL	4488-TB-45
38	LINKAGE PAWL (R SIDE STANDARD HOIST 2340mm WIDE)	4488-TB-43
	LINKAGE PAWL (R SIDE A SERIES HOIST 2700mm WIDE)	4488-TB-43A
39	LIMIT SWITCH ACTIVATOR	4488-TB-58
40-41	DETENT BALL ASSEMBLY	4488-TB-59
42	SPLIT PIN M2.5X12mm	4488-TB-49
43	PUSH ROD	4488-TB-48
44	COLLAR SLIDING	4488-TB-52
45	SPRING PUSH ROD	4488-TB-53
46	COLLAR FIXED	4488-TB-50
47	GRUB SCREW 1/4"WX1/4"	4488-TB-51
48	PAWL SAFETY MANUAL LOCKING (LEFT)	4488-TB-47
49	LINKAGE PAWL (L SIDE STANDARD HOIST 2340mm WIDE)	4488-TB-44
	LINKAGE PAWL (L SIDE A SERIES HOIST 2700mm WIDE)	4488-TB-44A

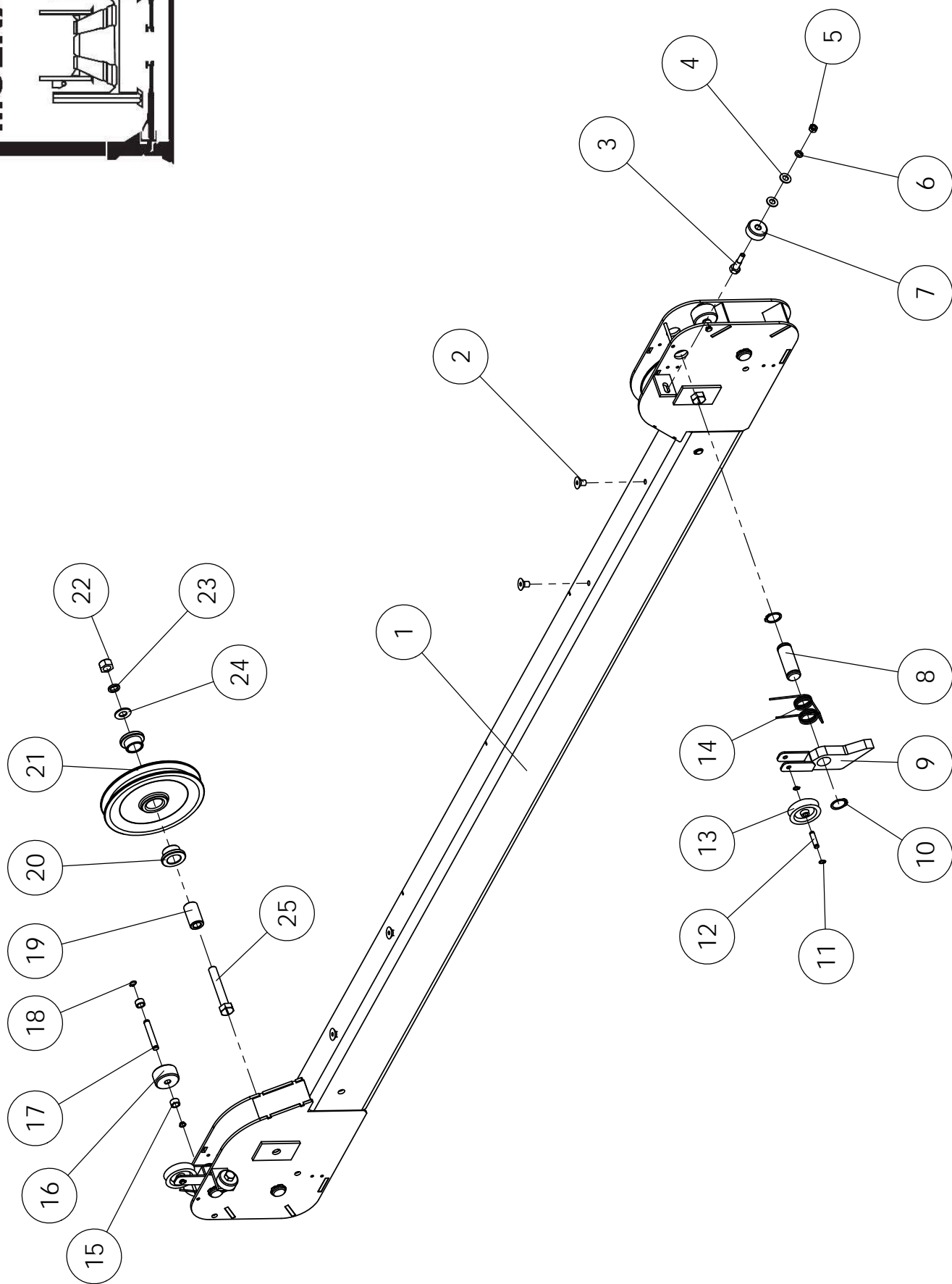
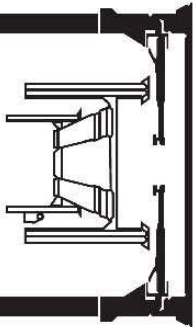

TRANSVERSE BEAM-NON CONTROL END

TRANSVERSE BEAM-NON CONTROL END

ITEM #	PART DESCRIPTION	SPARE PART #
1	TRANSVERSE BEAM-NON CONTROL END	4488S/W-TB-12B
	TRANSVERSE BEAM-NON CONTROL END A SERIES	4488SA/WA-TB-12B
2	SCREW COUNTERSUNK HIGH TENSILE M10X16mm	4488-TB-38
3	BOLT SHOULDER	4488S/W-TB-30
4	WASHER FLAT M10	4488S/W-TB-28
5	NUT M8	4488S/W-TB-26
6	WASHER SPRING M8	4488S/W-TB-27
7	ROLLER TRANSVERSE BEAM ADJUSTABLE GUIDE	4488-TB-29
8	PIN SAFETY PAWL MANUAL	4488-TB-32
9	PAWL SAFETY AUTOMATIC	4488-TB-34
10	CIRCLIP 25mm (4 PER ASSEMBLY)	4488-TB-31
11	CIRCLIP 8mm (2 PER ASSEMBLY)	4488-TB-35
12	PIN PULLEY SAFETY PAWL AUTOMATIC	4488-TB-36
13	PULLEY AUTOMATIC SAFETY PAWL (NYLON)	4488-TB-37
14	SPRING SAFETY PAWL	4488-TB-33
15	SPACER END ROLLER	4488-TB-23
16	ROLLER TRANSVERSE BEAM END	4488-TB-25
17	PIN END ROLLER	4488-TB-24
18	CIRCLIP 10mm (12 PER ASSEMBLY)	4488-TB-22
19	BUSH STEEL PULLEY	4488-TB-16
20	BUSH TRANSVERSE BEAM (2 PER PULLEY)	4488-TB-17
21	PULLEY TRANSVERSE BEAM (INCLUDES BUSHES)	4488-TB-18
22	NUT 9/16" UNF	4488-TB-21
23	WASHER SPRING 9/16"	4488-TB-20
24	WASHER FLAT 9/16"	4488-TB-19
25	BOLT HIGH TENSILE 9/16"X3 1/2" UNF	4488-TB-15

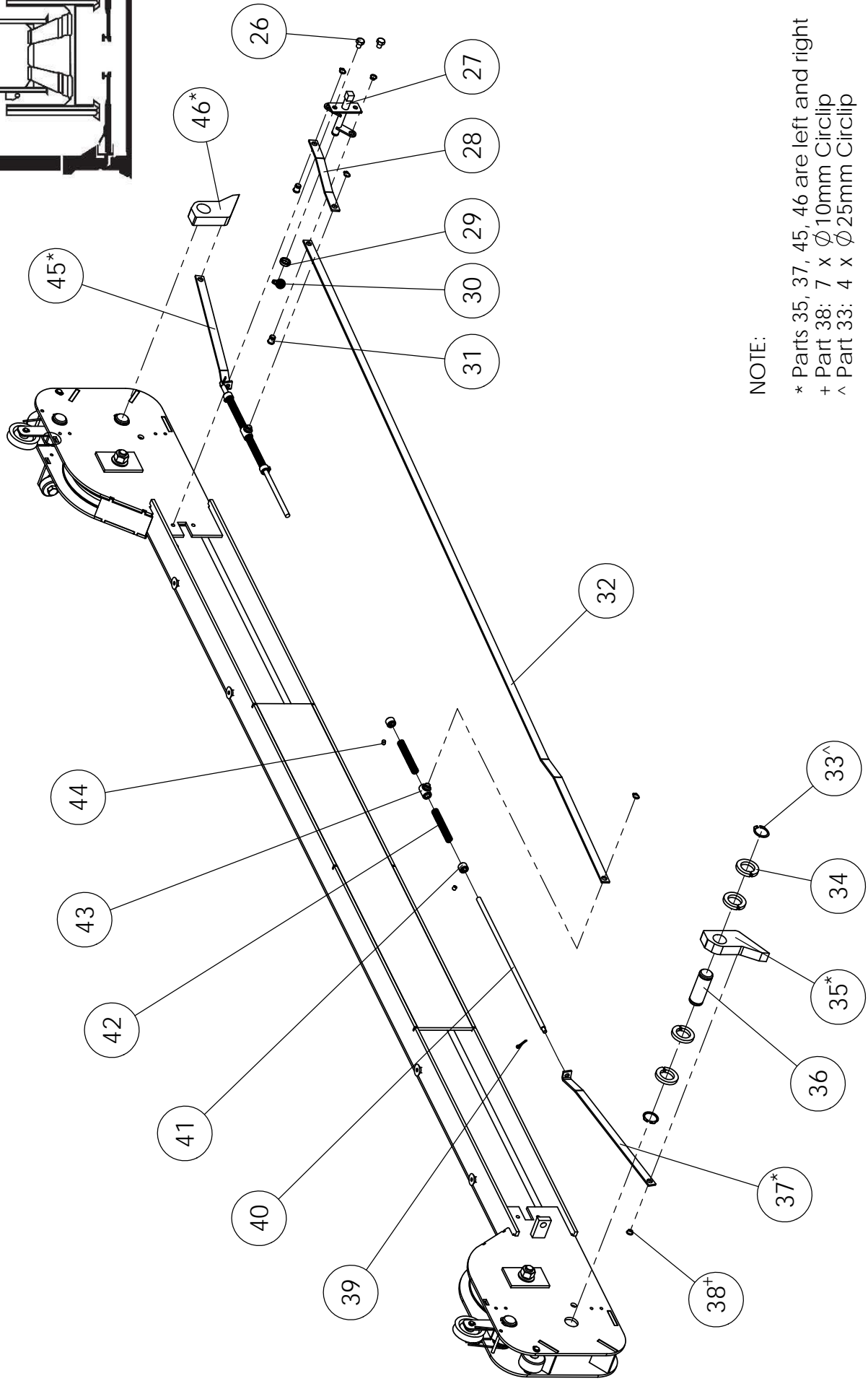
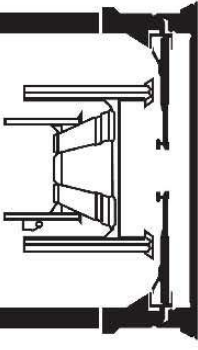

NOTE:

- * Parts 35, 37, 45, 46 are left and right
- + Part 38: 7 x Ø10mm Circlip
- ^ Part 33: 4 x Ø25mm Circlip

TRANSVERSE BEAM-NON CONTROL END

ITEM #	PART DESCRIPTION	SPARE PART #
26	BOLT 5/16"X1/2" WHITWORTH	4488-TB-56
27	ACTIVATING BRACKET TRANSVERSE BEAM	4488-TB-55
28	LINKAGE SHORT TRANSVERSE BEAM	4488-TB-41
29	SPACER ACTIVATING BRACKET	4488-TB-57
30	CIRCLIP 12mm	4488-TB-39
31	PIN SAFETY	4488-TB-40
32	LINKAGE LONG (STANDARD HOIST 2340mm WIDE)	4488-TB-42
	LINKAGE LONG (A SERIES HOIST 2700mm WIDE)	4488-TB-42A
33	CIRCLIP 25mm (4 PER ASSEMBLY)	4488-TB-31
34	SPACER SAFETY PAWL MANUAL	4488-TB-45
35	PAWL SAFETY MANUAL LOCKING (RIGHT)	4488-TB-46
36	PIN SAFETY PAWL MANUAL	4488-TB-32
37	LINKAGE PAWL (R SIDE STANDARD HOIST 2340mm WIDE)	4488-TB-43
	LINKAGE PAWL (R SIDE A SERIES HOIST 2700mm WIDE)	4488-TB-43A
38	CIRCLIP 10mm (7 PER ASSEMBLY)	4488-TB-22
39	SPLIT PIN M2.5X12mm	4488-TB-49
40	PUSH ROD	4488-TB-48
41	COLLAR FIXED	4488-TB-50
42	SPRING PUSH ROD	4488-TB-53
43	COLLAR SLIDING	4488-TB-52
44	GRUB SCREW 1/4"WX1/4"	4488-TB-51
45	LINKAGE PAWL (L SIDE STANDARD HOIST 2340mm WIDE)	4488-TB-44
	LINKAGE PAWL (L SIDE A SERIES HOIST 2700mm WIDE)	4488-TB-44A
46	PAWL SAFETY MANUAL LOCKING (LEFT)	4488-TB-47

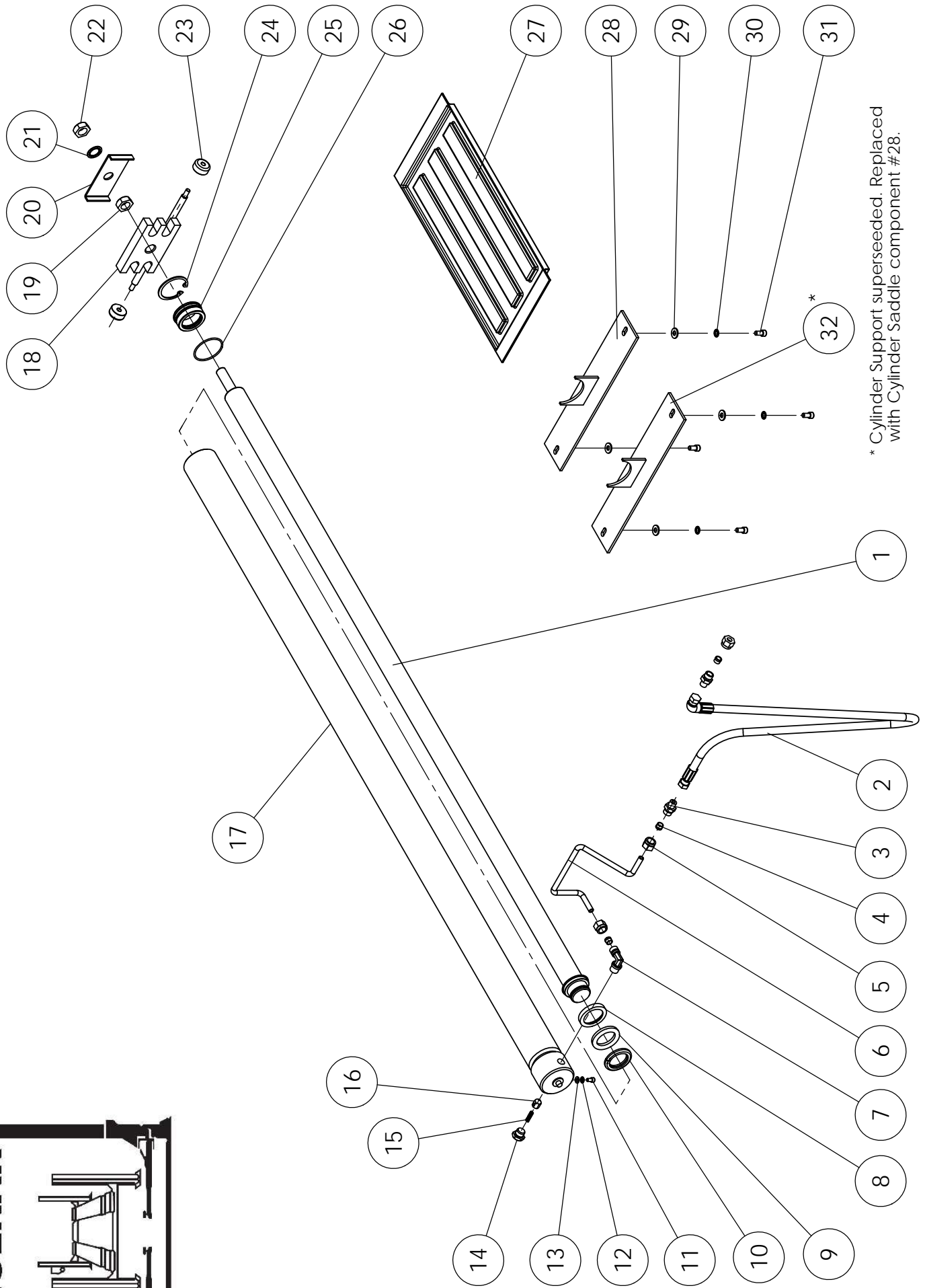
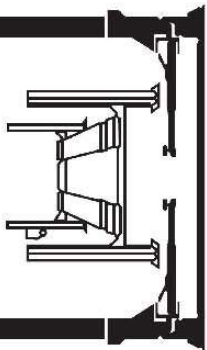

* Cylinder Support superseded. Replaced with Cylinder Saddle component #28.

CYLINDER ASSEMBLY

ITEM #	PART DESCRIPTION	SPARE PART #
1	PISTON ROD	4488-C-104
2	HYDRAULIC HOSE	4488-C-120
3	ADAPTOR HYDRAULIC STRAIGHT	4488-C-118
4	OLIVE 3/8"	4488-C-116
5	NUT HYDRAULIC ADAPTOR	4488-C-115
6	PIPE HYDRAULIC CYLINDER	4488-C-119
7	ADAPTOR HYDRAULIC ELBOW	4488-C-117
8	WEAR RING	4488-C-109
9	SEAL	4488-C-110
	CYLINDER SEAL KIT (INCL. ITEMS # 8 WEAR RING (x1), # 9 SEAL (x1), # 10 RETAINER (x1), # 25 GUIDE BUSH (x1), # 26 O RING (x1))	4488-C-K110
10	RETAINER	4488-C-111
11	BOLT SOCKET HEAD M6X12mm	4488-C-75
12	WASHER SHAKEPROOF 1/4"	4488-C-76
13	WASHER FLAT 1/4"	4488-C-77
14	BOLT THROTTLE VALVE	4488-C-114
15	SPRING THROTTLE VALVE	4488-C-113
16	THROTTLE VALVE	4488-C-112
17	CYLINDER BARREL	4488-C-107
	HYDRAULIC CYLINDER ASSEMBLY	4488-C-AK107
18	CABLE BLOCK	4488-C-99
19	NUT LOCK 3/4" WHITWORTH	4488-C-102
20	RETAINING PLATE	4488-C-101
21	WASHER SHAKEPROOF 3/4"	4488-C-103
22	NUT LOCK 3/4" WHITWORTH	4488-C-102
23	ROLLER (CABLE BLOCK)	4488-C-100
24	CIRCLIP 60mm	4488-C-105
25	GUIDE BUSH	4488-C-106
26	O RING 60mm	4488-C-106A
27	DRIP TRAY	4488-C-DRPT
28	HYDRAULIC CYLINDER SADDLE	4488-C-86
29	WASHER FLAT M8	4488-C-89
30	WASHER SHAKEPROOF M8	4488-C-88
31	BOLT SOCKET HEAD M8X16mm	4488-C-87
32	USE 4488-C-86 (ITEM # 28)	4488-C-86A

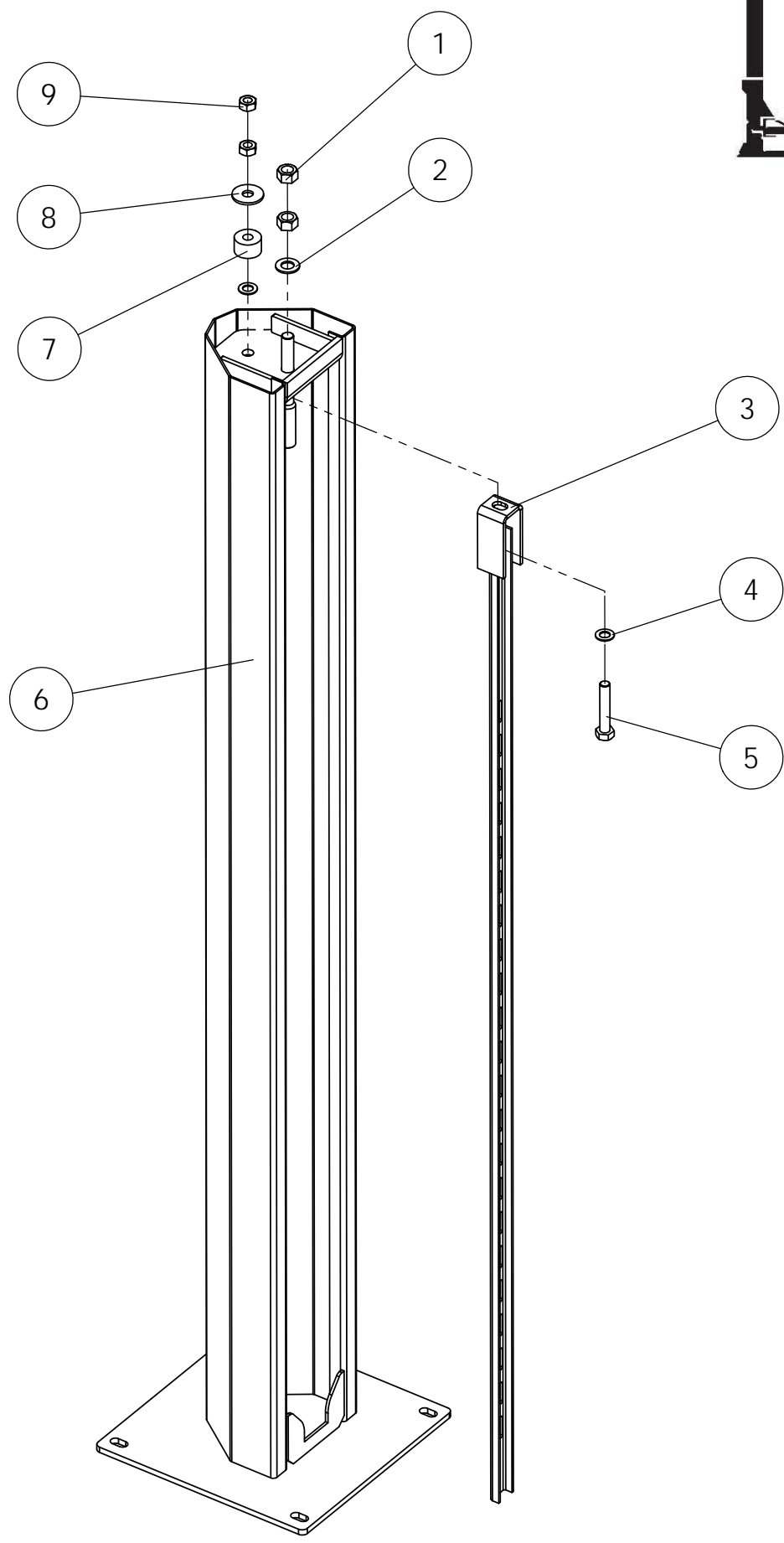
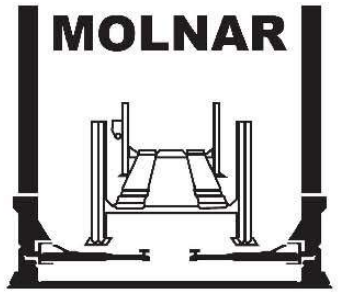

POST ASSEMBLY

ITEM #	PART DESCRIPTION	SPARE PART #
1	NUT CABLE 3/4" UNF	4488-P-7
2	WASHER CABLE 3/4"	4488-P-7A
3	SAFETY RAIL	4488-P-3
4	WASHER M16	4488-P-6
5	BOLT HIGH TENSILE M16X90mm	4488-P-4
6	POST CONTROL NO.1 (S/W/D)	4488S/W-P-1
	POST NON-CONTROL (S/W/D)	4488S/W-P-2
7	SHOCK ABSORBER RUBBER	4488-P-6A
8	WASHER SHOCK M16X50mmX4mm	4488-P-6B
9	NUT HIGH TENSILE M16	4488-P-5
	MOUNTING BOLT SAFETY ASSEMBLY KIT (EACH POST) (INCL. ITEMS # 4 WASHER M16 (x2), # 5 BOLT (x1), # 7 SHOCK RUBBER (x1), # 8 SHOCK WASHER (x1), # 9 NUT M16 (x2))	4488-P-4A

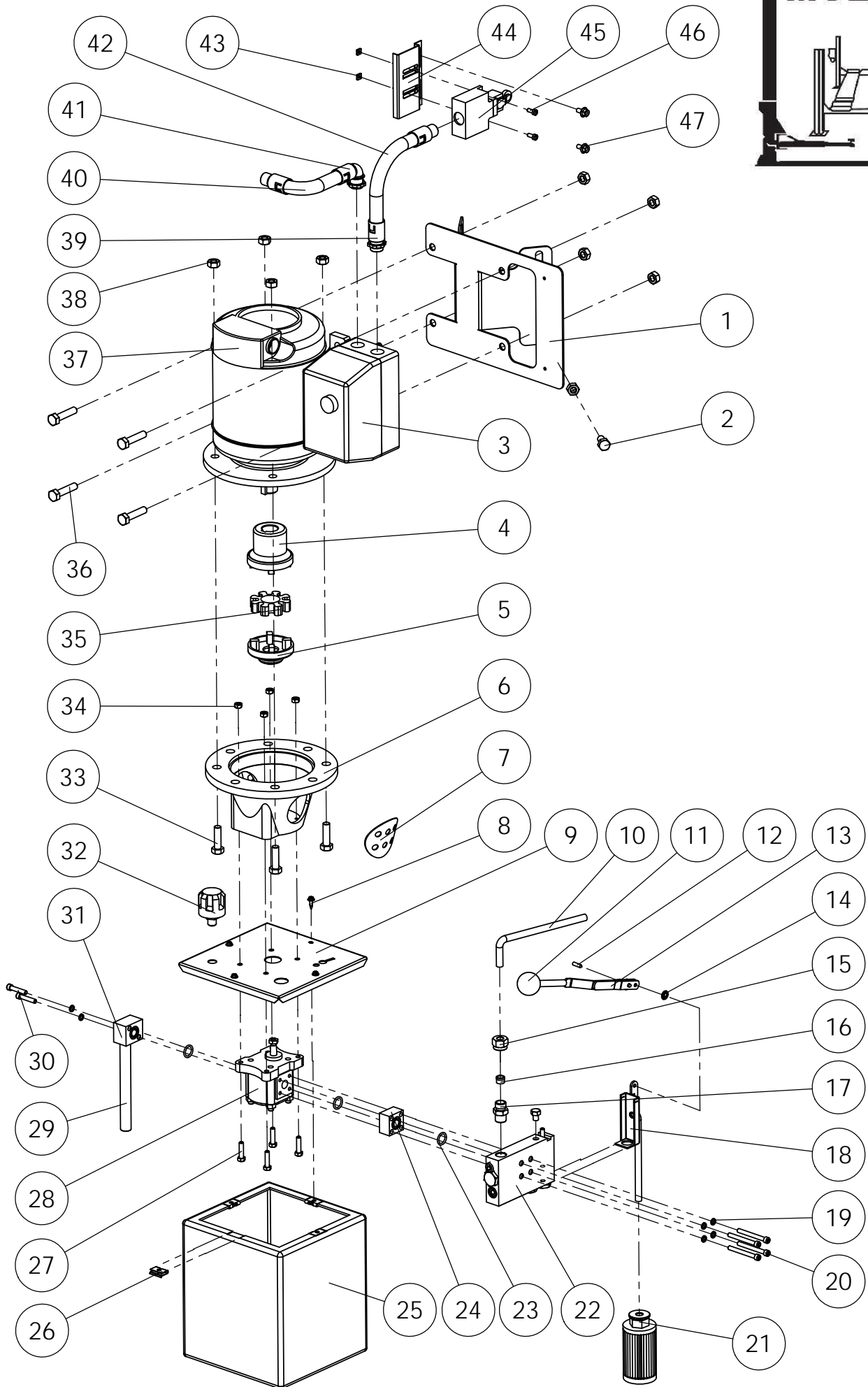
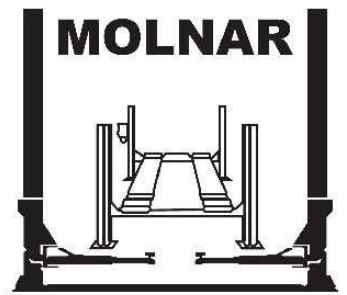

POWER PACK ASSEMBLY

ITEM #	PART DESCRIPTION	SPARE PART #
1	BRACKET MOTOR MOUNT	4488-S/W-PP-169
2	BOLT MOTOR MOUNTING BRACKET M10X20mm	4488-PP-170
3	STARTER BOX-TP (415V 3 PHASE)	4488-PP-164
	STARTER BOX-SP (240V SINGLE PHASE)	4488-PP-164SP
4	COUPLING MOTOR	4488-PP-154
5	COUPLING PUMP	4488-PP-158
6	BELL HOUSING	4488-PP-155
7	COUPLING GUARD	4488-PP-155G
8	SCREW TANK/LID 8GX15mm	4488-PP-125
9	TANK LID	4488-PP-123
10	HYDRAULIC PIPE WITH FITTING (TANK)	4488-PP-121
11	HANDLE GRIP	4488-PP-126B
12	PIN PIVOT	4488-PP-127
13	HANDLE LOWERING	4488-PP-126
14	SPEED CLIP	4488-PP-128
15	NUT HYDRAULIC ADAPTOR	4488-PP-115
16	OLIVE 3/8"	4488-PP-116
17	ADAPTOR HYDRAULIC STRAIGHT	4488-PP-118
18	BRACKET CONTROL VALVE	85A-F-175
19	WASHER SPRING VALVE BODY 1/4"X1/16"X1/16"	4488-PP-146
20	BOLT VALVE BODY M6X55mm	4488-PP-145
21	FILTER	4488-PP-139
22	CONTROL VALVE ASSEMBLY	4488-PP-129
	CONTROL VALVE ASSEMBLY-RECONDITIONED	4488-PP-129REC
23	O RING 12mm	4488-PP-148
24	ADAPTOR PUMP MANIFOLD	4488-PP-177
25	TANK (EMPTY NO OIL)	4488-PP-122
	TANK HYDRAULIC ASSEMBLY	4488-PP-122A
	OIL CASTROL AWH 46 (5 LITRE)	OIL/H
26	NUT SPEED	4488-PP-305
27	BOLT 1/4"X1" (ZINC)	4488-PP-147
28	HYDRAULIC PUMP	4488-PP-150
29	ADAPTOR PUMP EXTENSION	4488-PP-153
30	BOLT VALVE BODY M6X35mm	4488-PP-145
31	ADAPTOR PUMP PICK UP	4488-PP-152
32	BREATHER	4488-PP-124
33	BOLT BELL HOUSING M10X35mm	4488-PP-156
34	NUT 1/4" (ZINC)	4488-PP-149
35	COUPLING RUBBER	4488-PP-158A
36	BOLT MOUNTING M10X25mm	4488-PP-168
37	MOTOR 415V 3 PHASE (INCLUDES COUPLING)	4488-PP-159TP
	MOTOR 240V SINGLE PHASE (INCLUDES COUPLING)	4488-PP-159SP
38	NUT BELL HOUSING M10	4488-PP-157
39	ADAPTOR STRAIGHT CONDUIT M20	4488-PP-303
40	CONDUIT M20	4488-PP-162
41	ADAPTOR ELBOW CONDUIT M20	4488-PP-304
42	CONDUIT M20	4488-PP-165
43	NUT LIMIT SWITCH MOUNTING M5	4488-PP-175
44	BRACKET LIMIT SWITCH	4488-PP-173
45	LIMIT SWITCH	4488-PP-172
46	BOLT LIMIT SWITCH MOUNTING M5X12mm	4488-PP-174
47	BOLT M6X12mm	4488-R-64
	POWER PACK ASSEMBLY 415VOLT	4488-PP
	POWER PACK ASSEMBLY 240VOLT	4488-PP-240V

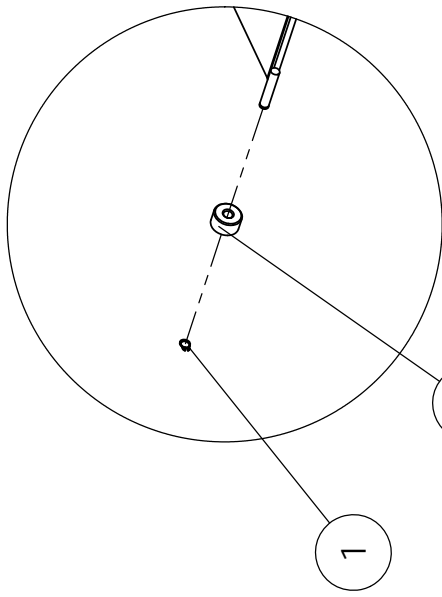
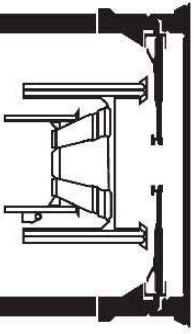

1

2

4

3

4

5

6

7

LEFT HAND PLATFORM

ITEM #	PART DESCRIPTION	SPARE PART #
1	CIRCLIP M8	4488-S/W-66EL-C
2	ROLLER (EXTRA LONG RUN-UP)	4488-S/W-66EL-R
3	RUN-UP ASSEMBLY (EXTRA LONG - 1190mm)	4488-S/W-66EL
4	PLATFORM LEFT HAND (WITH WHEEL ALIGNMENT RECESS)	4488-W-R-67
	PLATFORM LEFT HAND (WITHOUT WHEEL ALIGNMENT RECESS)	4488-S-R-67
	PLATFORM LEFT HAND (D SERIES 4,000mm LONG)	4488-D-R-67
5	WHEEL ALIGNMENT RECESS COVER	4488-R-68
6	WHEEL STOP	4488-S/W-65
7	RUN-UP (STANDARD - 815mm)	4488-S/W-66

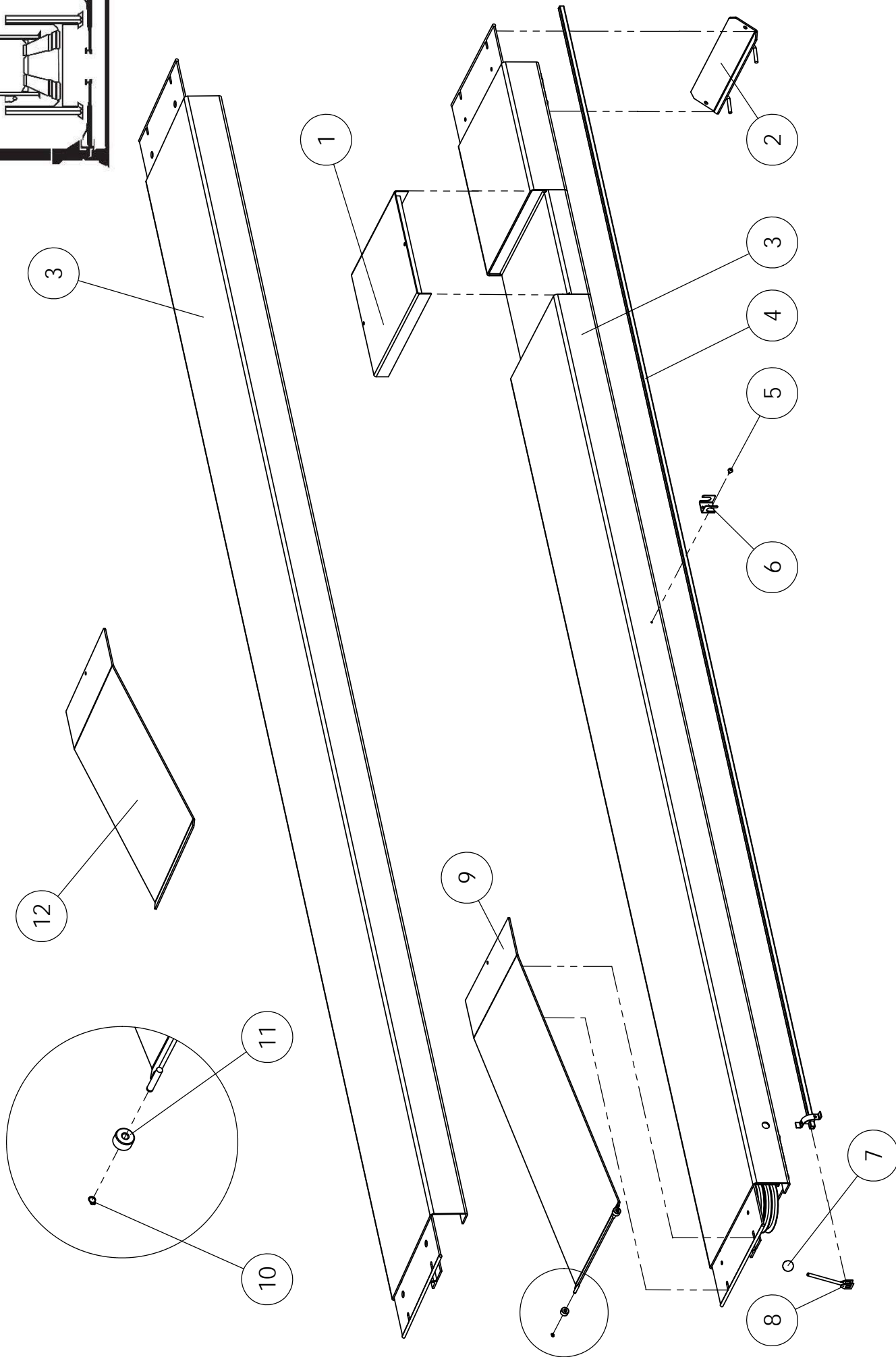
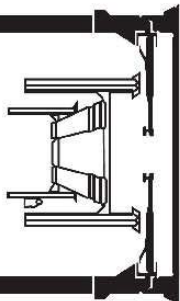

RIGHT HAND PLATFORM

ITEM #	PART DESCRIPTION	SPARE PART #
1	WHEEL ALIGNMENT RECESS COVER	4488-R-68
2	WHEEL STOP	4488-S/W-65
3	PLATFORM RIGHT HAND (WITH WHEEL ALIGNMENT RECESS)	4488-W-R-69
	PLATFORM RIGHT HAND (WITHOUT WHEEL ALIGNMENT RECESS)	4488-S-R-69
	PLATFORM RIGHT HAND (D SERIES 4,000mm LONG)	4488-D-R-69
4	ACTUATING BAR LONG	4488-R-61
	ACTUATING BAR (D SERIES)	4488-R-61D
5	BOLT M6X12mm	4488-R-64
6	BRACKET	4488-R-63
7	HANDLE GRIP	4488-PP-126B
8	HANDLE LOCKING MECHANISM	4488-R/WR-62
9	RUN-UP ASSEMBLY (EXTRA LONG - 1190mm)	4488-S/W-66EL
10	CIRCLIP M8	4488-S/W-66EL-C
11	ROLLER (EXTRA LONG RUN-UP)	4488-S/W-66EL-R
12	RUN-UP (STANDARD - 815mm)	4488-S/W-66

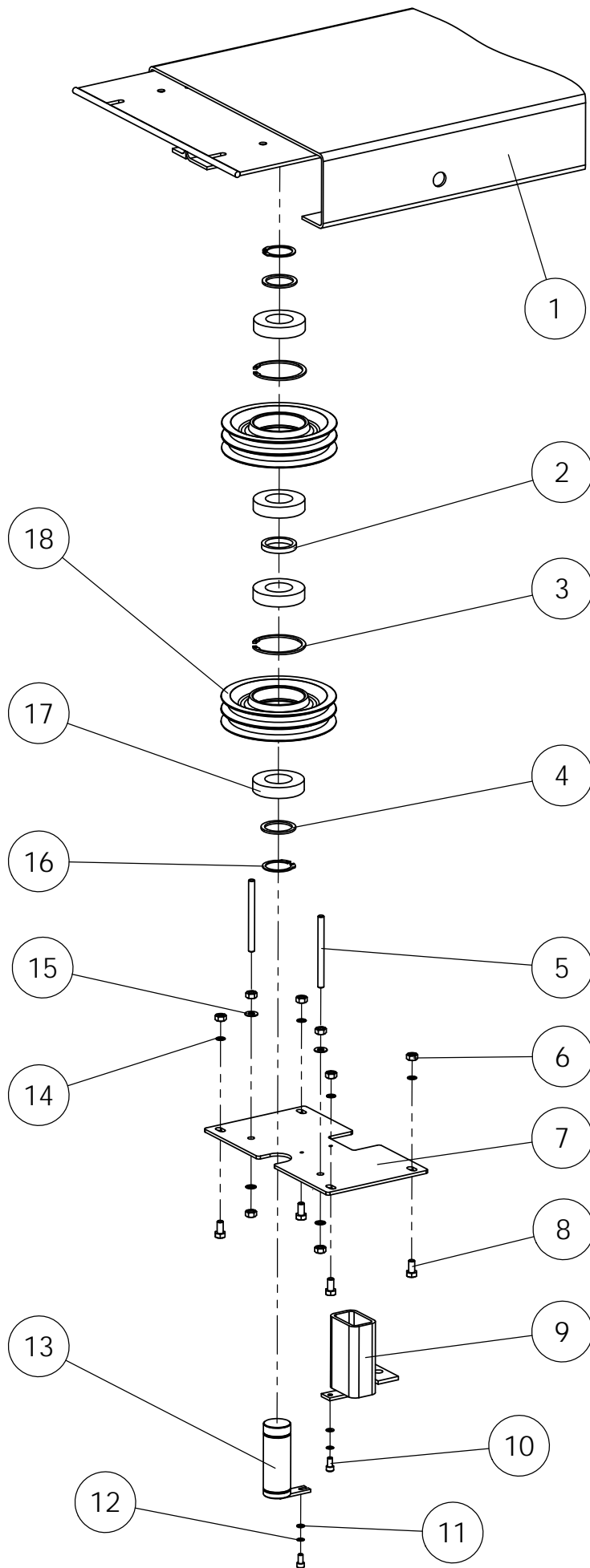
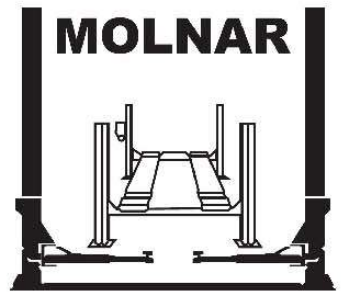

DOUBLE PULLEY ASSEMBLY



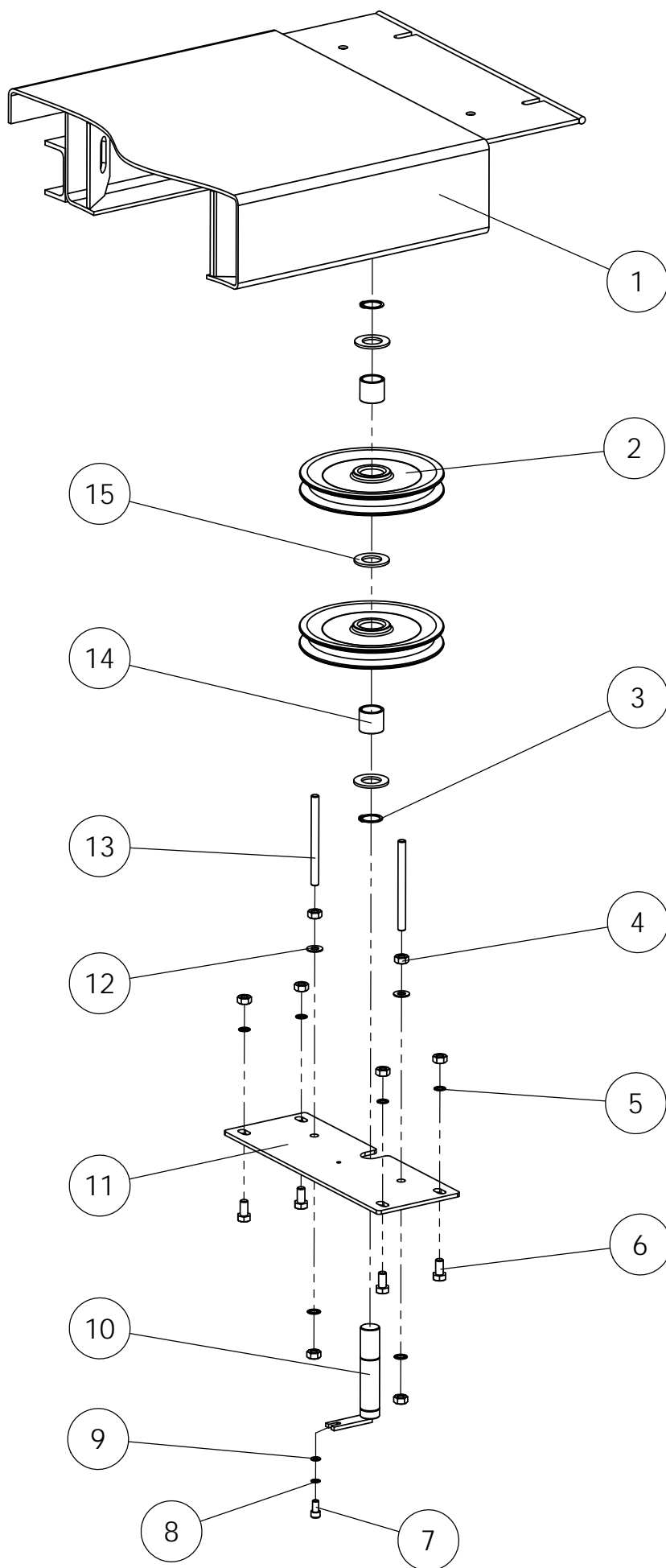
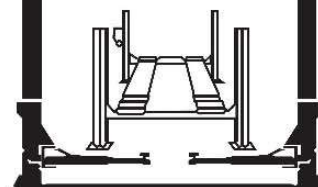





ITEM #	PART DESCRIPTION	SPARE PART #
1	PLATFORM RIGHT HAND (WITH WHEEL ALIGNMENT RECESS)	4488-W-R-69
	PLATFORM RIGHT HAND (WITHOUT WHEEL ALIGNMENT RECESS)	4488-S-R-69
	PLATFORM RIGHT HAND (D SERIES 4,000mm LONG)	4488-D-R-69
2	SPACER (MIDDLE)	4488-DP-97
3	CIRCLIP 85mm (INTERNAL)	4488-DP-96
4	SPACER (OUTER - 2 PER ASSEMBLY)	4488-DP-94
5	CABLE RETAINING PIN	4488-DP-70
6	NUT M10	4488-DP-84
7	SUPPORT PLATE	4488-DP-91
8	BOLT M10X20mm HIGH TENSILE	4488-DP-82
9	CYLINDER SUPPORT BLOCK	4488-DP-90
10	BOLT SOCKET HEAD M6X12mm	4488-DP-75
11	WASHER FLAT 1/4"	4488-DP-77
12	WASHER SPRING 1/4"	4488-DP-76
13	PIN DOUBLE PULLEY	4488-DP-92
14	WASHER SPRING M10	4488-DP-83
15	WASHER FLAT M10	4488-DP-71
16	CIRCLIP 44mm	4488-DP-93
17	BEARING (2 PER PULLEY)	4488-DP-95
18	PULLEY TWIN GROOVE	4488-DP-98
	PULLEY TWIN GROOVE WITH BEARING (x2)	4488-DP-98WB
	PULLEY TWIN GROOVE ASSEMBLY (INCL. ITEMS # 2 SPACER MIDDLE (x1), # 3 CIRCLIP 85mm (x2), #4 SPACER OUTER (x2), # 13 PIN (x1), # 16 CIRCLIP 44mm (x2), # 17 BEARING (x4), # 18 PULLEY (x2))	4488-DP



SINGLE PULLEY ASSEMBLY

ITEM #	PART DESCRIPTION	SPARE PART #
1	PLATFORM RIGHT HAND (WITH WHEEL ALIGNMENT RECESS)	4488-W-R-69
	PLATFORM RIGHT HAND (WITHOUT WHEEL ALIGNMENT RECESS)	4488-S-R-69
	PLATFORM RIGHT HAND (D SERIES 4,000mm LONG)	4488-D-R-69
2	PULLEY SINGLE GROOVE	4488-SP-18
3	CIRCLIP 25mm	4488-SP-78
4	NUT M10	4488-SP-72
5	WASHER SPRING M10	4488-SP-83
6	BOLT HIGH TENSILE M10X20mm	4488-SP-82
7	BOLT SOCKET HEAD HIGH TENSILE M6X12mm	4488-SP-75
8	WASHER SPRING 1/4"	4488-SP-76
9	WASHER FLAT 1/4"	4488-SP-77
10	PIN SINGLE PULLEY	4488-SP-74
11	SUPPORT PLATE	4488-SP-81
12	WASHER FLAT M10	4488-SP-71
13	PIN CABLE RETAINING	4488-SP-70
14	BUSH (SINGLE GROOVE PULLEY)	4488-SP-80
15	SPACER (3 PER ASSEMBLY)	4488-SP-79
	PULLEY SINGLE GROOVE ASSEMBLY (INCL. ITEMS # 2 PULLEY (x2), # 3 CIRCLIP 25mm (x2), #10 PIN (x1), # 14 BUSH (x2), # 15 SPACER (x3))	4488-SP

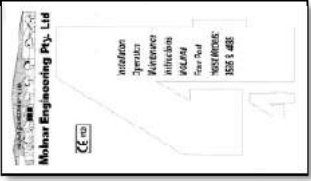
STICKERS

ITEM #	DESCRIPTION	SPARE PART #
1		STICKER-DNJ
2		STICKERS/H
3		STICKERS
4		4488S/W-DECAL
5		4488SA/WA-DECAL
6		4488D-DECAL
7		ON/OFF
8		4488MANUAL
9		OIL/H

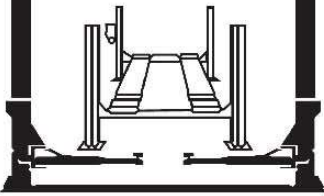

OPTIONAL MOLNAR JACKING BEAM

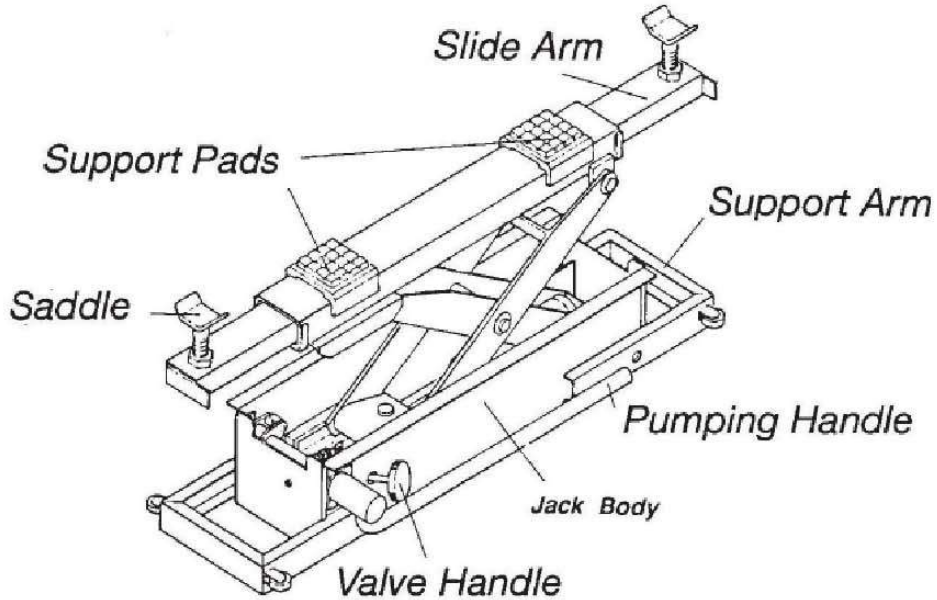

OPTIONAL JACKING BEAM ACCESSORIES:

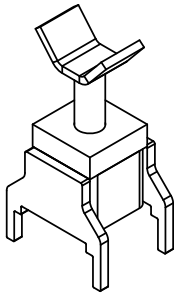

Axle Pick Up
(PART NO. AXLE-PU)

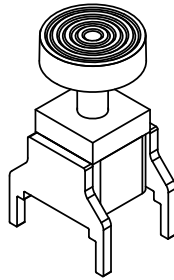

Extension Pad
(PART NO. EXT-PAD)

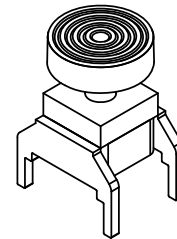

Extension Pad Low
(PART NO. EXT PAD-LOW)

MODELS:

JB 87- Standard width Jacking Beam used on hoists;
Models 4488S, 4488W and 4488D.

JB 87A- Wider model Jacking Beam used on hoists;
Models 4488SA and 4488WA.

MOLNAR

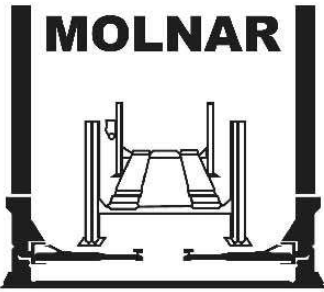

OPTIONAL MOLNAR JACK STAND

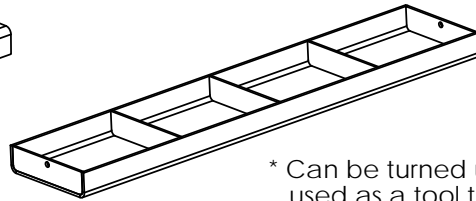
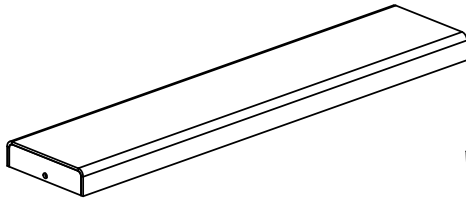

* Can be turned upside down and used as a tool tray.

JACK STAND

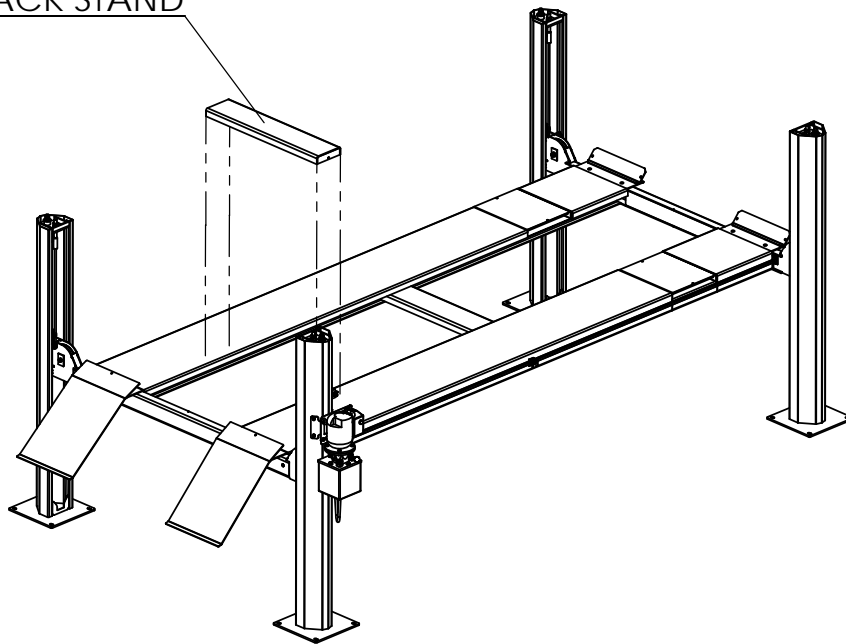

MODELS:

PART NO. 7252-023-01 - Standard width Jack Stand used on hoists; 4488S, 4488W, 4488D.

PART NO. 7252-023-01A - Wider model Jack Stand used on hoists; 4488SA, 4488WA.

COMMENTS:

CHANGING FROM 415VAC 3PHASE MOTOR TO 240VAC SINGLE PHASE MOTOR

MOTOR 240V SINGLE PHASE (INCLUDES COUPLING). PART NO. 4488-PP-159SP

USE EXISTING MOTOR MOUNT BOLTS

MOLNAR ENGINEERING STRONGLY ADVISES CONSULTING A QUALIFIED ELECTRICIAN
BEFORE COMMENCING CONVERSION

ELECTRICIAN

- HOIST MUST BE WIRED BY A QUALIFIED ELECTRICIAN ACCORDING TO AS3000 OR SUPPLY AUTHORITY REGULATIONS
- MINIMUM SUPPLY CIRCUIT RATING REQUIRED 20 AMP
- MODIFY WIRING ON HOIST TO SUIT SINGLE PHASE
- EXCHANGE 415VAC CONTACTOR TO A 240VAC CONTACTOR INSIDE THE STARTER BOX OR REPLACE ENTIRE 415VAC STARTER BOX WITH 240VAC STARTER BOX (STARTER BOX-SP (240V SINGLE PHASE) PART NO. 4488-PP-164SP)

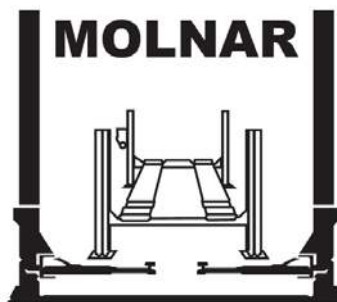

MANUFACTURED BY:

MOLNAR ENGINEERING PTY. LTD.

A.B.N. 54 007 740 794

16-20 Coglin Street, Brompton, S.A. 5007 AUSTRALIA
Telephone: (08) 8346 6893, (08) 8346 6894, (08) 8346 8006
Fax: (08) 8346 0097, Web: www.molnarhoists.com.au
Email: spareparts@molnarhoists.com.au