

*Installation Manual for Molnar
Hoists Two Post Hoist (4.5 Tonne)
M245-A*

UNIVERSAL INSTALLATION

M O L N A R



Contents Page

<u>Required Equipment</u>	<u>Page 2</u>
<u>Overview</u>	<u>Page 3</u>
<u>Hoist Packing Identification and Marking Out</u>	<u>Page 4</u>
<u>Unpacking</u>	<u>Page 5</u>
<u>Removal of Posts From Pallet</u>	<u>Page 6</u>
<u>Standing Posts</u>	<u>Page 7</u>
<u>Anchor bolts Requirements</u>	<u>Page 8</u>
<u>Floor Specification</u>	<u>Page 9</u>
<u>Floor Repair Information</u>	<u>Page 10</u>
<u>Balance Cable Layout</u>	<u>Page 11</u>
<u>Pulley Layout</u>	<u>Page 12</u>
<u>Balance Cable Fitting</u>	<u>Page 13</u>
<u>Top Brace Assembly</u>	<u>Page 14</u>
<u>Safety Release Cable</u>	<u>Page 15</u>
<u>Hydraulic Connections</u>	<u>Page 16</u>
<u>Wiring and Electrical</u>	<u>Page 18</u>
<u>Wiring Diagrams</u>	<u>Page 18</u>
<u>Hydraulic Circuit</u>	<u>Page 19</u>
<u>Lift Arms</u>	<u>Page 19</u>
<u>Balance Cable Adjustment</u>	<u>Page 20</u>
<u>Lubrication and Hydraulic Bleeding</u>	<u>Page 20</u>
<u>Covers</u>	<u>Page 21</u>
<u>Commissioning</u>	<u>Page 21</u>
<u>Install check list</u>	<u>Page 22</u>

Note:- this manual is accurate at time of printing (November / 2016)

Molnar Hoists reserves the rights to change specifications in the interests of modifications and ongoing product developments.

Required Equipment

Personal protective equipment

Gloves

Ear & eye protection

Steel capped boots



Safety cones, warning signs and tape



Electrician

A licensed electrician must perform all electrical work including power connection and wiring.

power requirements

415V - 6.5 AMPS - 3 PH+EARTH

OR 240 Volts under load at motor, hard wired on 20 Amp circuit (if installing an optional Single Phase motor)



Lubricant

Recommended

Grease	> EP grade grease
General lubricant	> CRC Tac-2 > Wurth HHS Lube
Wire Rope lube	> Lanotec heavy duty liquid lanolin
Hydraulic oil *	> AWH 46 Weight hydraulic oil Min 8 Ltrs - Max 14Ltrs (A different weight oil may be required in different climates.)

Materials

An assortment of shimming in various thicknesses.

Note shimming should be minimum size of 50 X 75mm and either zinc steel or construction grade plastic.
appropriate concrete grout

Anchor Bolts *

16 X Ramset Tru-bolts 16mm X 150mm Galvinised
Part No. T16150GH
(minimum 7.5 kN hold down force per bolt is required)

Tools

2.4 metre platform-style step ladder
or an appropriate elevated work platform
Crane or appropriate lifting device
Pallet jack or appropriate material handling device
1200mm spirit level
Pry bar - heavy and light duty
Hammer drill with a 16 mm masonry drill bit
Tin snips
2 tape measures
Chalk line
Oil funnel

Standard tool kit

- > 2 screwdrivers
- > Phillips Head screwdriver
- > Metric Allan Key set
- > Clamp wrench (AKA vice grip)
- > Cutting pliers (AKA wire cutters)
- > Rubber mallet
- > Hammer
- > Adjustable wrench
- > 1/2" open ended spanner
- > 14 mm open ended spanner
- > Socket set
- > Punch
- > Needlenose pliers
- > External circlip pliers
- > Box cutter
- > Black Texta
- > Torque wrench
- > M22 eye bolt
- > Timber Bearers 100x75 x500mm
enough to have 4 stacks of approx
200mm high

* Note: Anchor Bolts and Hydraulic oil supplied with
Installation Kit Option (+T), not supplied Standard with hoist.

Overview

TOP VIEW

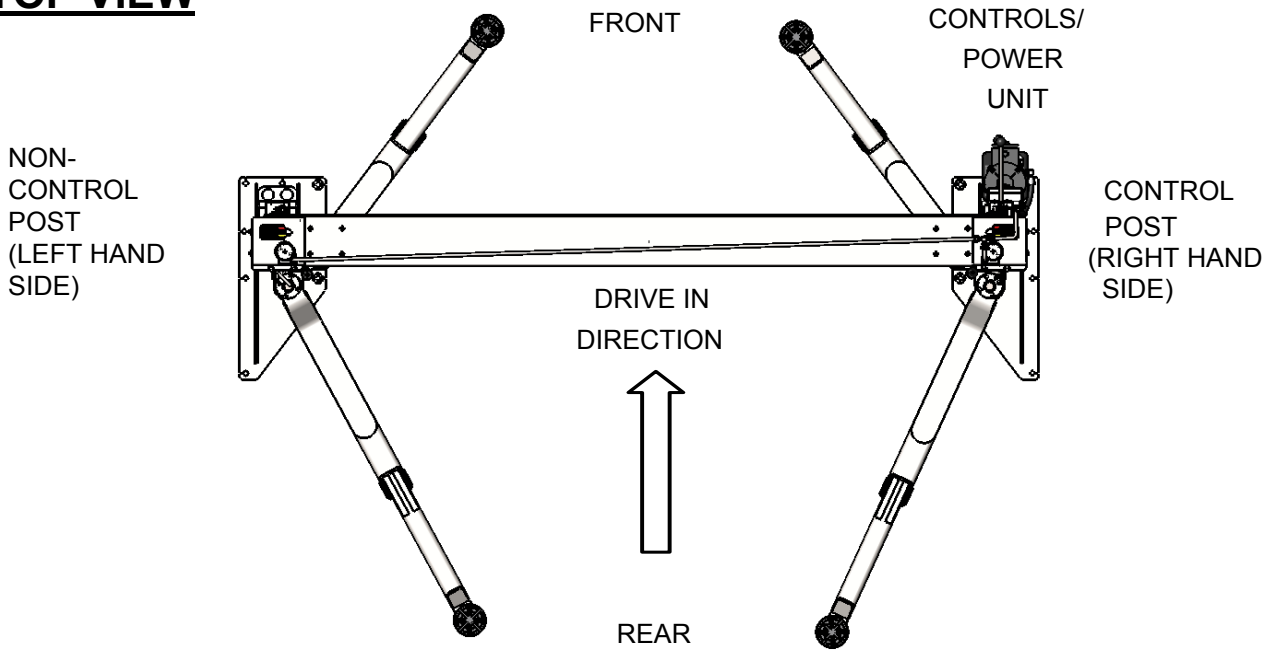

ISOMETRIC VIEW

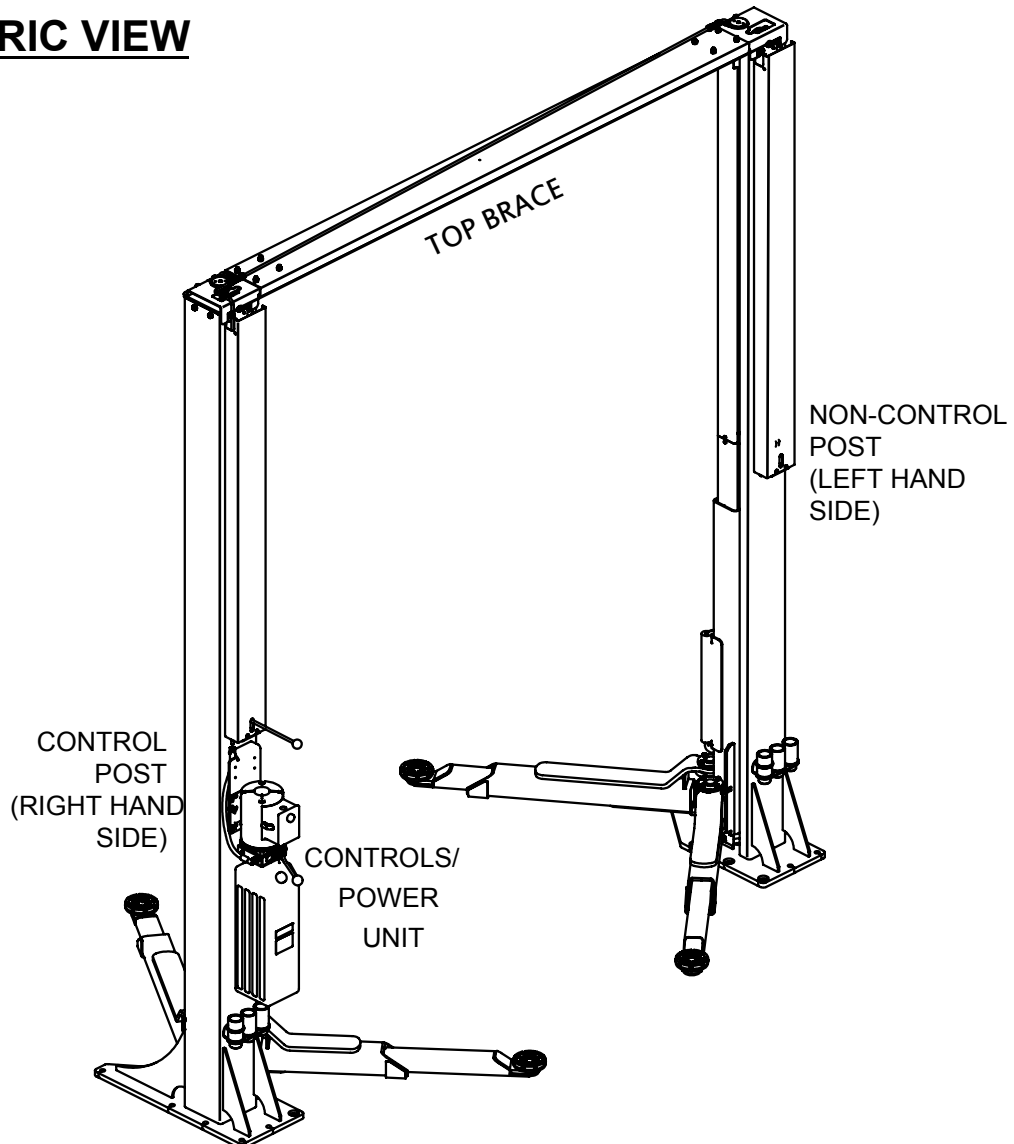

Hoist Packing Identification

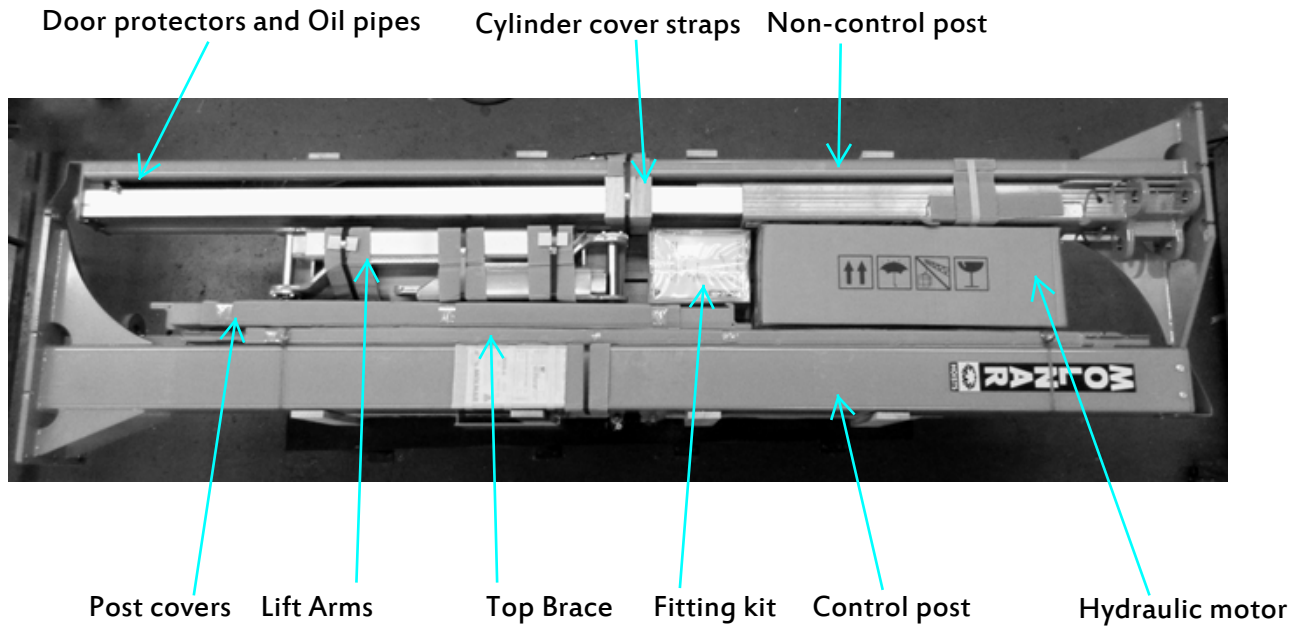

Marking Out

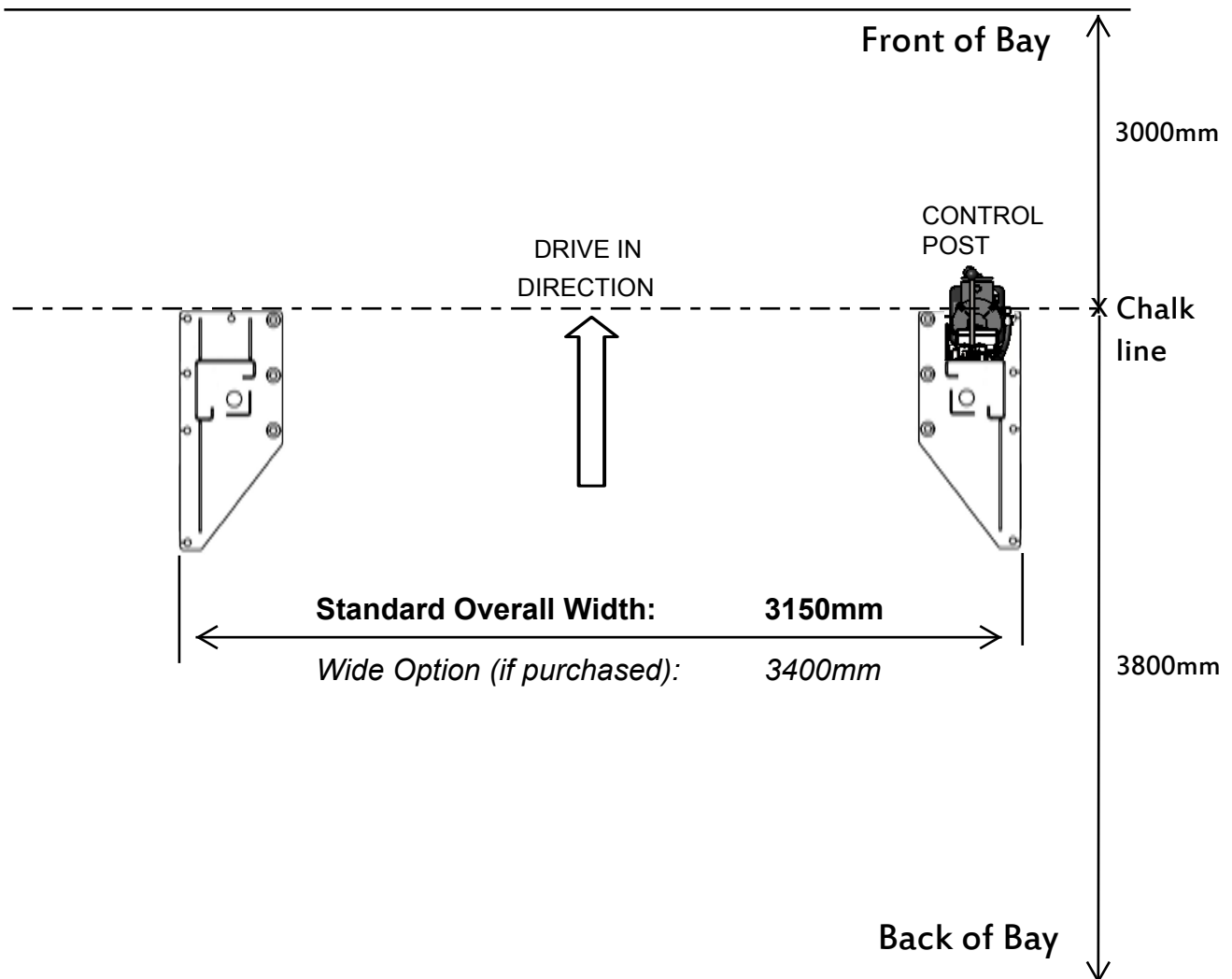
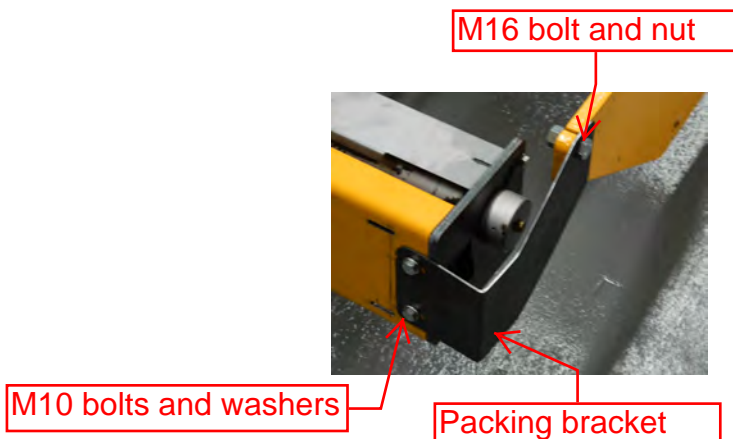

Diagram 1

Unpacking

1. Cut and remove the hoist pallet outer strapping then remove all the top bearer timbers. Remove the white plastic covers. All the removed packaging can be discarded.
2. Remove the fitting kit with the hoist manual. Thoroughly read the installation instructions before commencing installation.
NOTE: Before proceeding, all personnel installing the vehicle hoist should familiarise themselves with the full set of current installation instructions. Failure to install the hoist correctly may render it unsafe and void the product warranty.
3. Check that the floor meets the installation requirements as detailed on PAGE 9.
4. Check you have the necessary, tools, equipment, and installation items to complete the installation.
CHECKLISTS ARE ON PAGE 2
5. Mark out the bay as per DIAGRAM 1 using a chalk line to mark the line of the front edge of post base plates.
6. Position the hoist package in front of the chalk line.
7. Open the fittings box and check contents against the packing list contained inside the kit and then set aside.
8. Remove the motor box, top brace and post covers from the hoist package and set aside.
CAUTION: The M245 lifting arms are very heavy, do not lift unassisted!
9. Remove lifting arms from hoist pack and set aside (the lifting arms can be lifted as one pallet by only cutting the 2 top straps. To remove each arm individually, cut all 5 straps.
10. Remove all outer upright timbers from the sides of the hoist pallet.
11. Unbolt the packing brackets from the ends of the posts. Refit the M10 bolts approx. 2 turns back into the post from where they were removed. Keep the M10 washers as they will be refitted later in the installation.
The packing brackets, M16bolts and nuts can be discarded.



Removal of Posts From Pallet

12. Place 2 stacks of timber bearers on the ground at the ends of the pallet as close as possible to level with the bearers the posts are currently on.
13. Roll each post off the pallet and onto the bearers, as indicated below, and remove pallet. You can check this is correct as the long edge of the base plates should be parallel and the closest to the ground.

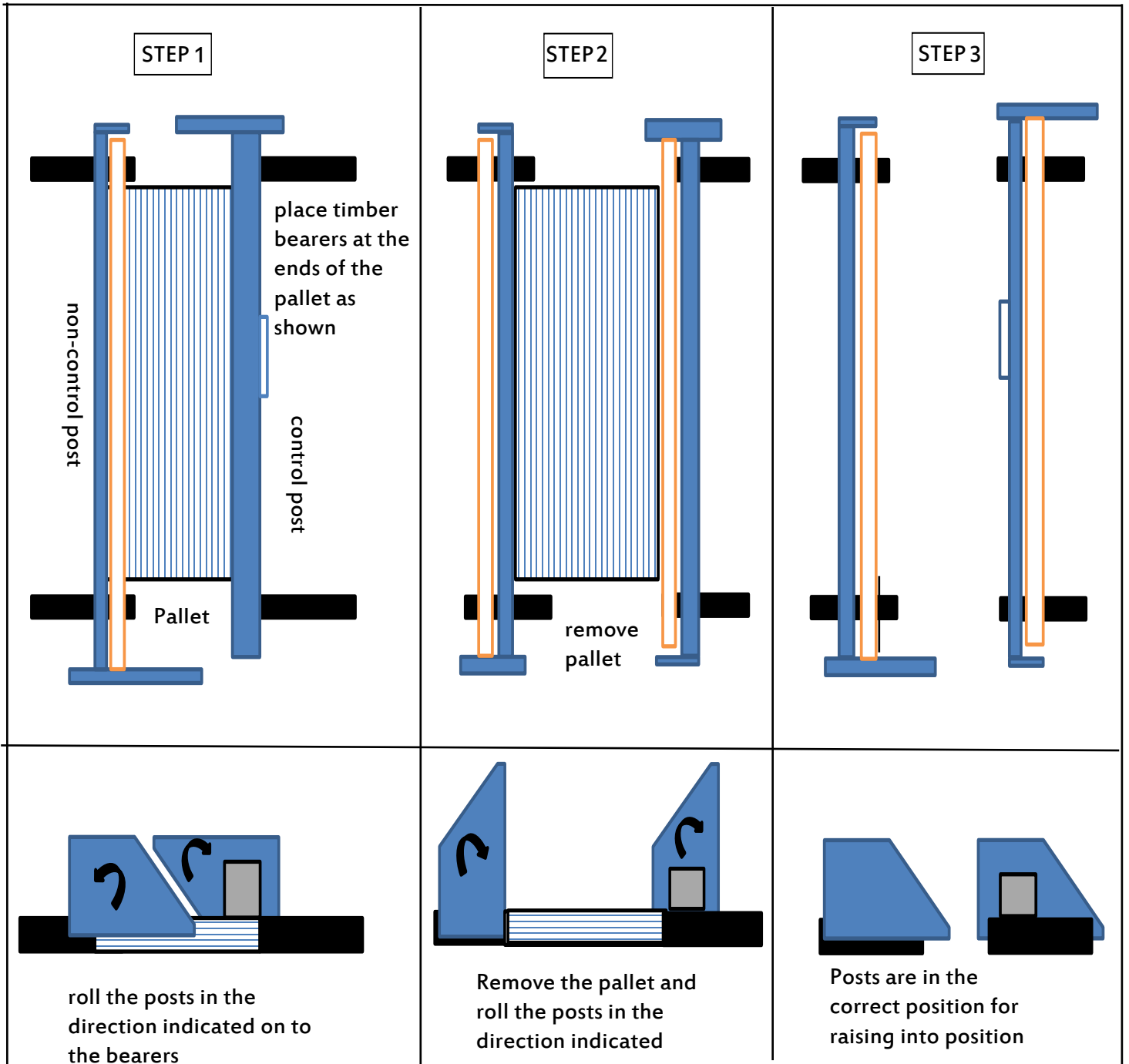

14. Remove the cylinder cover straps.
15. Remove the cylinder covers from the posts and set to one side. To avoid losing the cylinder cover screws, it is recommended to refit them while the covers are off.
16. Remove the cylinder support blocks, hydraulic pipes and door buffers packed inside the posts.
17. Slide each carriage up their post until the first lock position is engaged.

Standing Posts

CAUTION: *The M245 posts are extremely heavy, do not lift unassisted!*

CAUTION: *Do not sling around or apply any force to the cylinders when lifting the posts; this may result in damage to the cylinder and void warranty.*

1. A crane or similar lifting device is recommended for lifting posts. There are 2 x 22mm eyebolt holes in each post which are the designated lift points. Fit a M22 eyebolt in 1 of the lifting points and attach an appropriate sling.

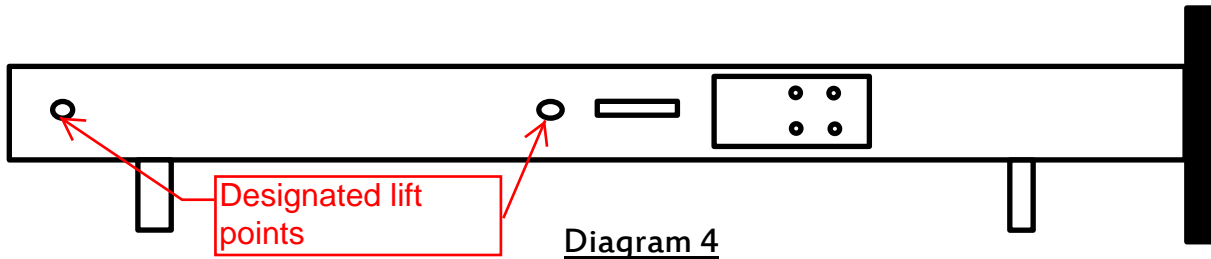

2. Lift one post into an upright position and set down in a position as close to its final installed location as possible.

3. Using a crane and a sling or other support method, secure the post in its vertical position to prevent it from falling while finalising its position.

Use a long straight edge to check the front edge of the base plate against the chalk line. Double check measurements to ensure the post is in the correct position.

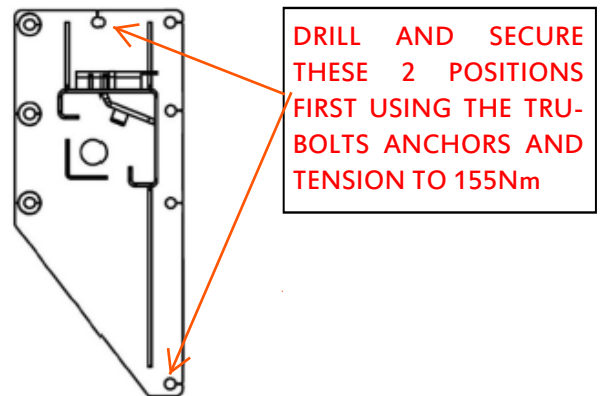

4. Fit 2 of the anchor bolts to the 2 holes in the post base plate as shown in **Diagram 5**. Please refer to the anchor bolt installation instructions in this manual for full detailed instructions. The eyebolt and the post support can be removed once the 2 anchor bolts have secured the post.

5. Repeat steps 1-4 for the other post.

6. Using a tape measure, check that the posts are in line, square and the correct distance from one another, refer to **DIAGRAM 1**.

7. **Levelling Posts**

Once posts are in position and secured, check posts for vertical alignment, in both planes, using a spirit level. Shim posts adjacent to the anchor bolt holes in the base plate.

NOTE: the maximum allowable amount of shimming is 10mm at any point. If shimming is used, the centre of the base plate must be supported by shims or an appropriate cement grout.

Tru-Bolt Anchor Installation

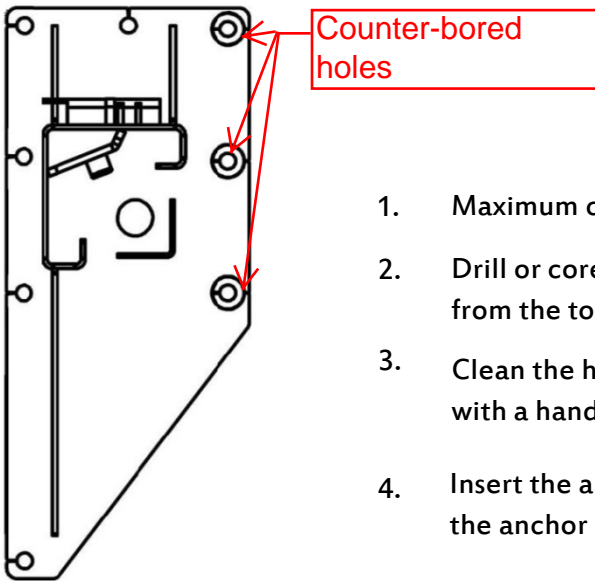
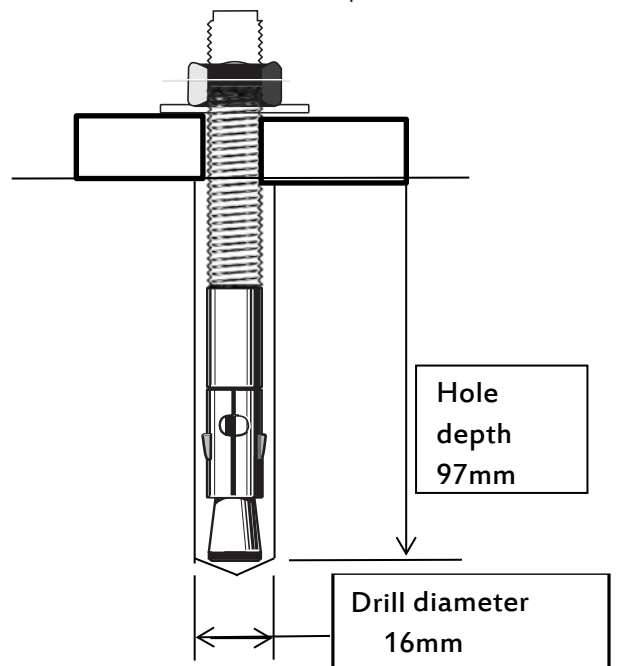
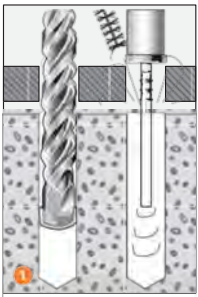

Diagram 6

Use Ramset P/No T16150GH Tru-bolts

(16mm diameter X 150mm long in a galvanised finish)

1. Maximum combined thickness of base plate, washer and shims is **25mm**.
2. Drill or core a hole of 16mm diameter and a depth of 97mm measured from the top surface of the concrete. Use the fixture as a template.
3. Clean the hole thoroughly with a hole cleaning brush. Remove the debris with a hand pump, compressed air, or vacuum.
4. Insert the anchor through the fixture and drive with a hammer until either the anchor bottoms out in the hole or the washer contacts the base plate.
5. Tighten the nut with a torque wrench to 155 Nm assembly torque.
6. After tightening to correct torque, the threads above the nuts on the bolts in the counter-bored holes need to be removed. Coat the bare metal with zinc paint.



Floor Specification

Fully Cured, Reinforced Concrete Slab (in Good Condition) on Compacted Base

Recommended Concrete Thickness:	135mm
Minimum Concrete Thickness:	100mm
Recommended Concrete Compressive Strength:	32MPa
Minimum Concrete Compressive Strength:	25MPa
Minimum Reinforcement Specifications:	SL72 Mesh with 30mm cover
Minimum Concrete Base Thickness:	100mm
Minimum Concrete Base Specifications:	Quarry Rubble compacted to 95% MMDD
Minimum Distance from Bolt Hole to Existing Bolt Holes:	200mm

WARNING:

Do not install the M245 where the minimum anchor bolt requirements and specifications cannot be satisfied.

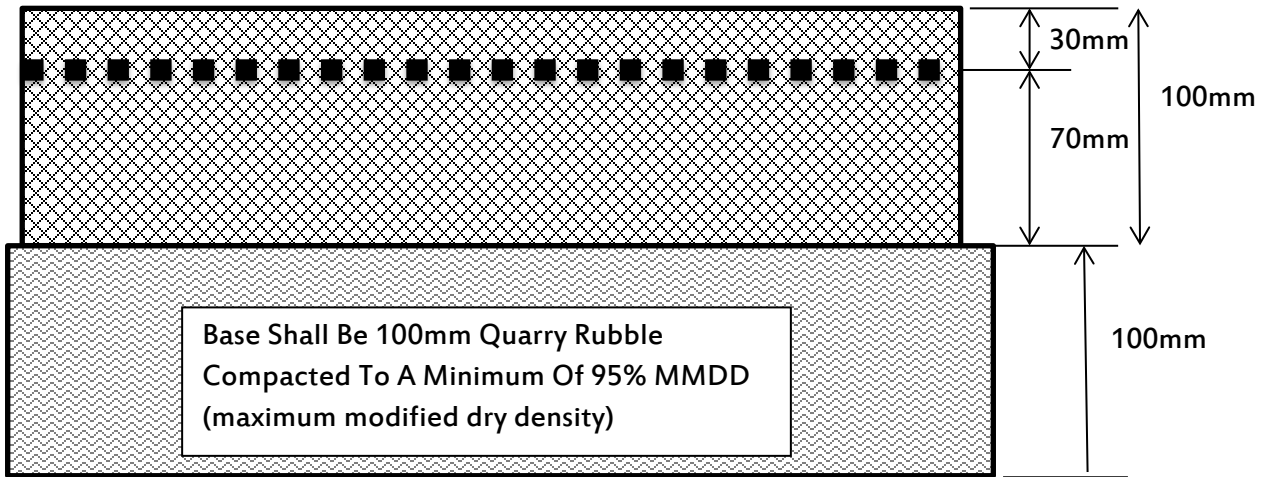

Minimum Distance to Concrete Edge
(including expansion joints, cold joints, etc.)

THICKNESS REQUIRED CLEARANCE

Thickness mm	Dimension A	Dimension B
100	1200	630
125	1075	568
135	1025	543
150	950	505
175	825	443
200	700	380

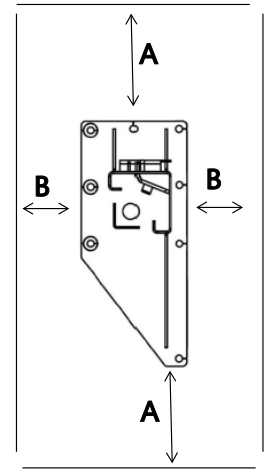
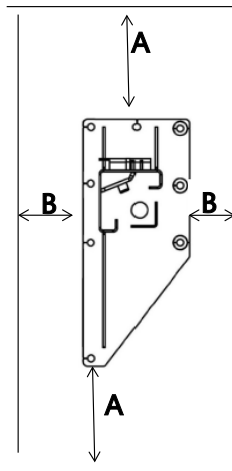

Floor Repair Information

If floor is less than 100mm thick or if the anchor bolts cannot be torqued to 155Nm the floor will need to be cut out to the following specifications.

Cut the existing floor to a minimum pad size of 4000mm X 2200mm
dig out base to a depth of 200 mm Minimum and under cut
existing slab by 200 mm

Ensure the base is compacted to 95% MMDD

Insert pins in old slab to lock the slabs together

Concrete must be a minimum of 32 Mpa grade and a depth of 200mm

Steel mesh must be a minimum of SL82

Slab must be let to cure for a minimum of 14 days before installing the hoist

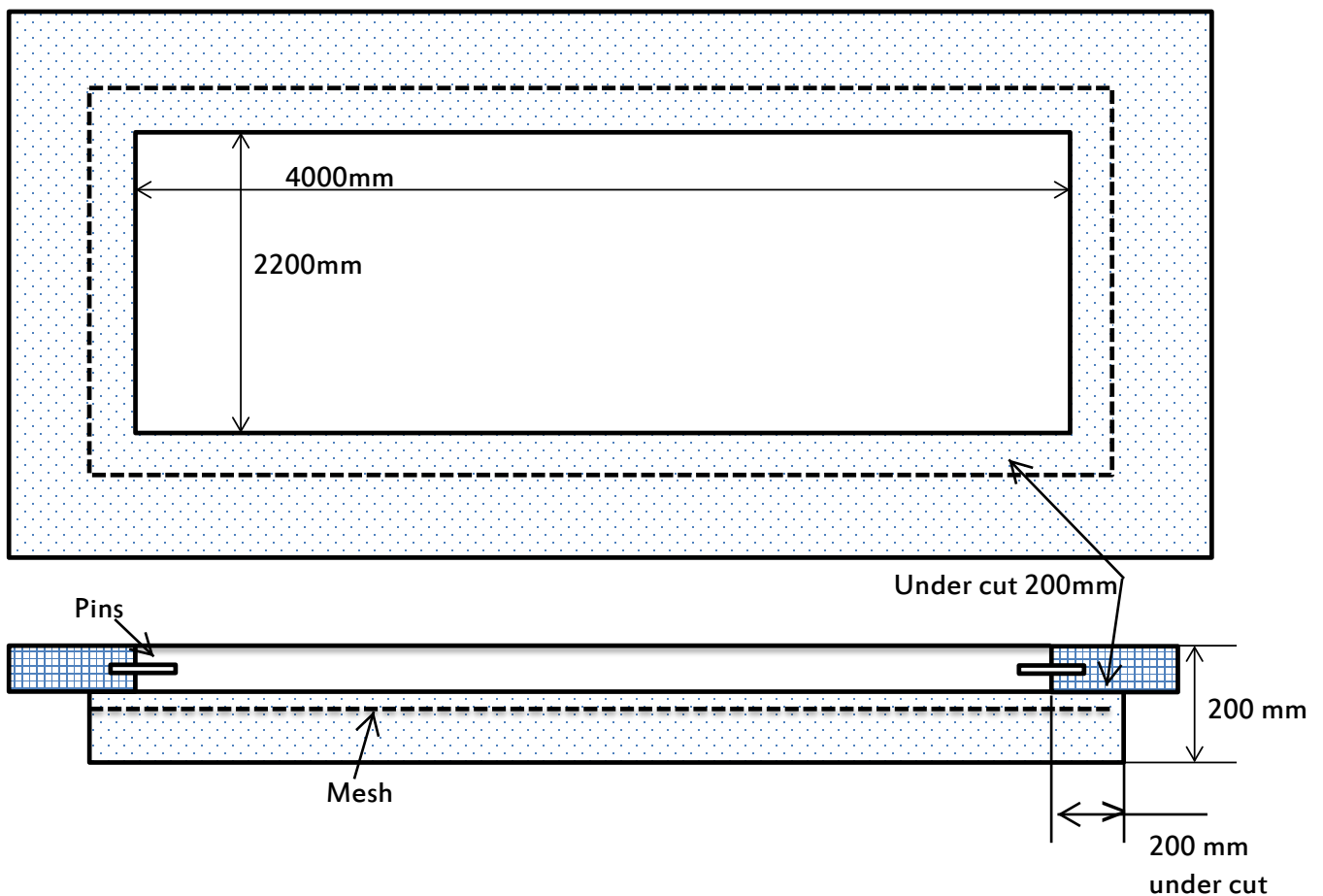

Balance Cable Layout

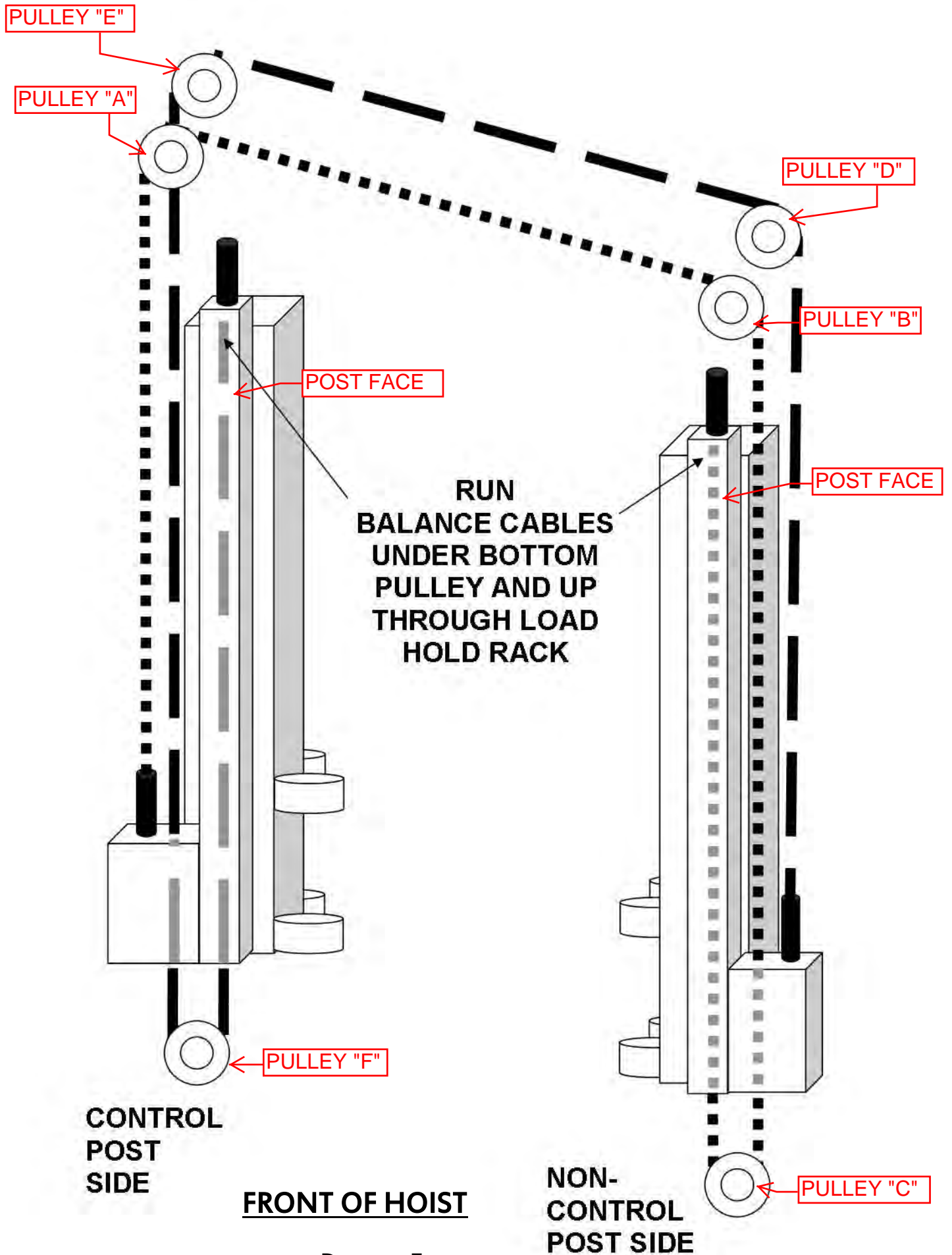

Diagram 7

Pulley Layout

CONTROL POST

NON-CONTROL POST

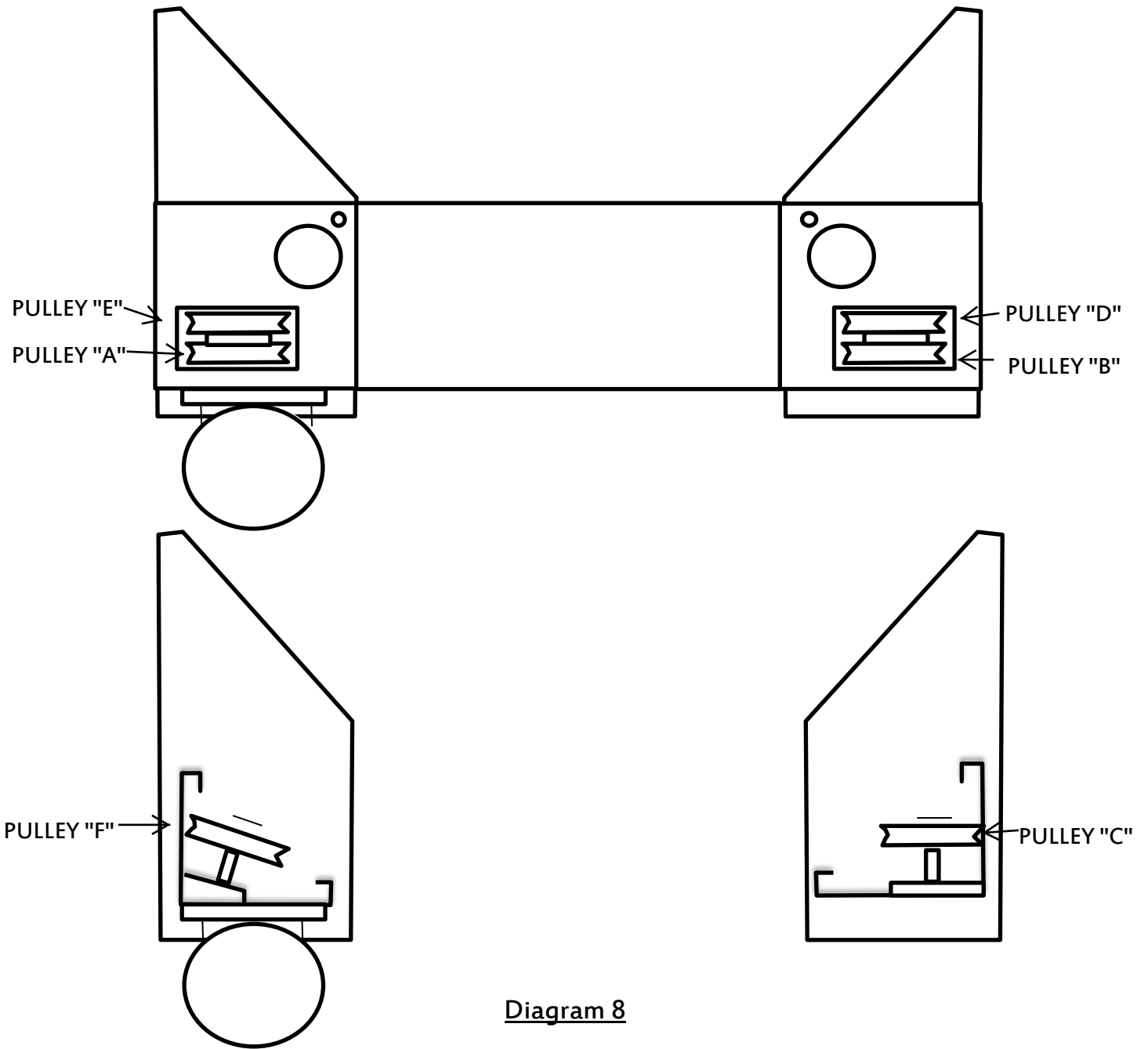
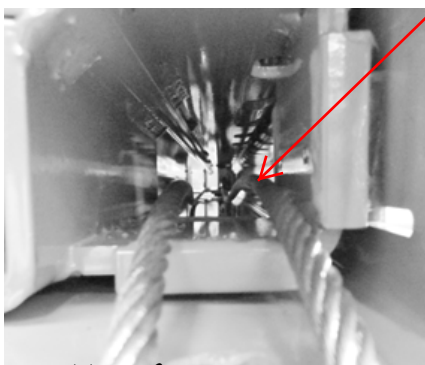

Diagram 8

ENSURE the cable is run through these points

Feed cable up through the safety rack



Top of carriage

Diagram 9

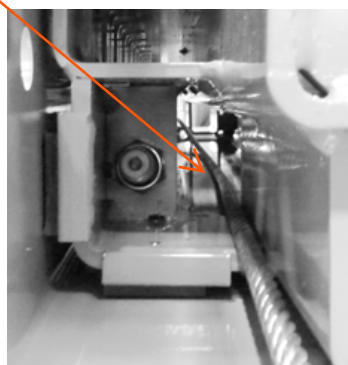

Bottom of carriage

12

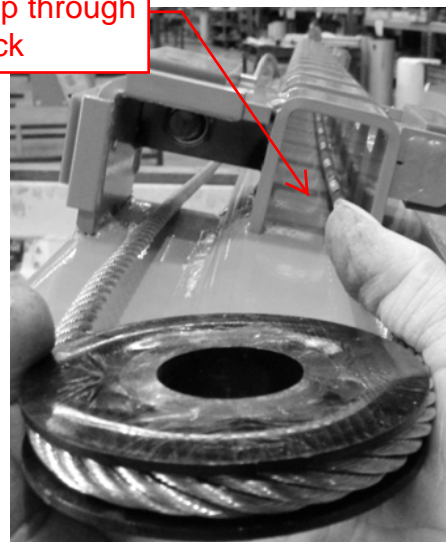

Diagram 10

Balance Cable Fitting

Use the balance cable layout on page 11 for correct positioning of ballance cables

Note: There are 2 balance cables per hoist. One end of each balance cable will be factory fitted to a carriage.

1. Remove the circlip and bottom balance cable pulleys from both the control post and non-control post.
2. Uncoil the balance cable from inside the control post and remove the nyloc nut, ensuring the cable is not knotted or damaged including the treaded end.

NOTE refer to pulley I.D. in diagram 7 & 8

3. Feed the cable end up inside the control post and out through the post top cap between the pulleys, fit the cable onto the pulley **A** and continue to pull the cable untill all excess is taken up. Ensure the cable is not wrapped around the cylinder.
4. Feed the cable across to the top of the non-control post, feed the cable down through the post top cap, between the pulleys. Fit the cable on the pulley **B** and continue to pull the cable untill all excess is taken up.
5. Feed the cable end between the carriage and post, on the non-control post, to the bottom of the post, ensure the cable is run through the positions indicated in diagram 9, and then feedback up through the centre of the safety rack (diagram 10). Fit end through the hole on the top of the safety rack and secure, finger tight. with the M16 nylock nut previously removed.
6. Place the bottom pulley **C** over the cable and refit pulley on to the pin and refit circlip.
7. Repeat steps 2-6 for the non-control post balance cable with the exception that the cable locates on the pulleys **D, E & F**.
8. Check to ensure that the cables are not crossed or wrapped around each other during installation.
9. Do not tension the balance cables at this time (see section on balance cable adjustment on page 21)

Top Brace Assembly

1. Remove the top sensor bar and all packaging from the top brace assembly.
2. The top brace assembly will arrive set for a standard width installation. Using 4 x M10 bolts, M10 nuts and M10 spring washers bolt the unsecured end of the top brace to the desired width.
3. Each post top cap should have 2 x M10 bolts half screwed in as per point 11 when unpacking the hoist. Using an appropriate lifting device or assisted lift, Lift the top brace up onto the post top caps and locate the slots on the side of the top brace end brackets onto the 2 x M10 bolts. Diagram11.

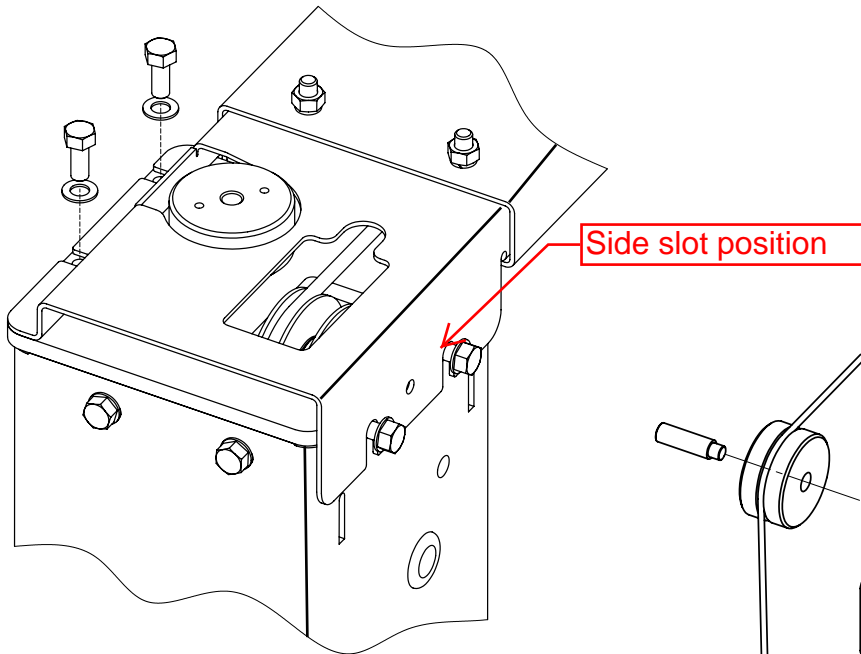

Diagram 11

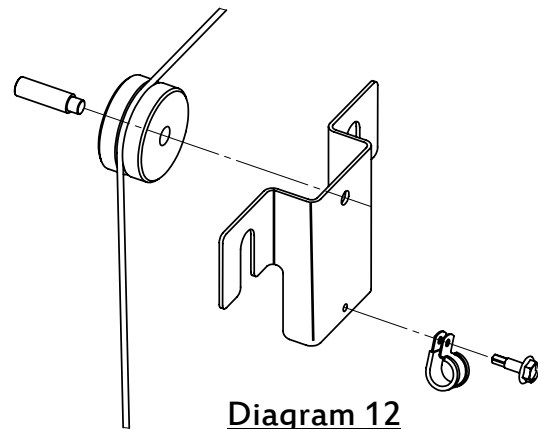

Diagram 12

4. Use the 2 x M10 washers previously removed from the packing bracket and refit to the M10 bolts in the face of the post (fit 1 at a time) fit the safety release cable roller, pin and bracket over these bolts and secure. Ensure the safety release cable roller is rotating freely.
5. Fit the M10 x 25 bolts and washers to the opposite side of the top brace.
6. Once all M10 bolts are started in position, tighten.

Safety Release Cable

1. Loosen the M8 nut on the control post safety release lever assembly, feed 1 end of the safety release cable through the hole on the control post safety assembly between the M8 flat washer and spring spool, pull approx. 30mm of the safety release cable through the hole and tighten the M8 nut and M8 spring washer. Note: Do not over tighten the M8 nut as this can cause damage to the safety release cable, leave a 2mm gap between the M8 washer and spring spool. (Diagram 13)

2. Run the other end of the safety release cable up the control post, around the safety release cable pulley located at the top of the control post, across the top of the hoist, around the non-control post side safety release cable pulley and then down the non-control post. (Diagram 14)

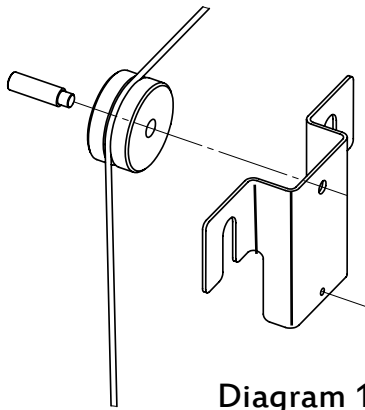

Diagram 14

3. Insert the cable through the hole, between the M8 washers on the non-control post safety mechanism, (diagram) pull the cable until it is firm and tighten the M8 nut. Note: Do not over tighten the M8 nut as this can cause damage to the safety release cable, leave a 2mm gap between the two M8 washers. (Diagram 15)

4. Fit the cover mounting bracket to the non-control post with 2 x M6 x 10mm screws. (Diagram 17)

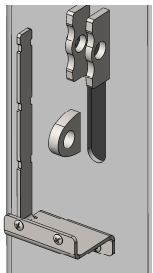

Diagram 16

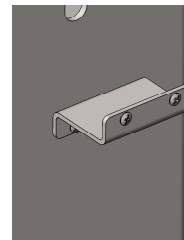

Diagram 17

5. Fit the M6 x 8mm grub screw in the lock handle mount on the control post safety release lever, insert handle and tighten the M6 x 8mm grub screw. Do not screw the black knob to the safety release lever at this time. (Diagram 13)

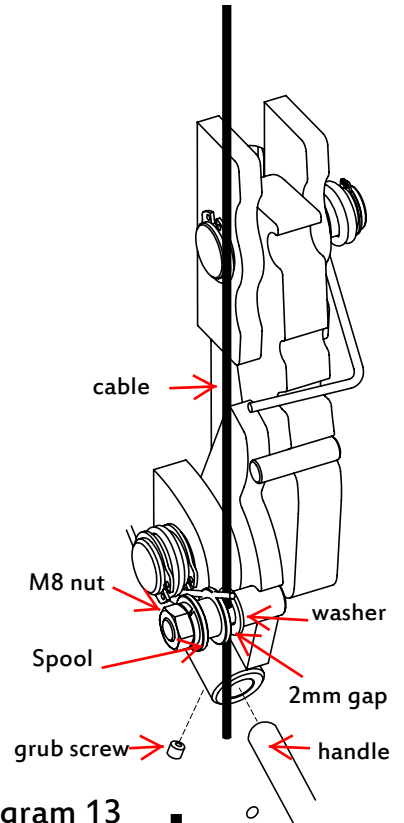

Diagram 13

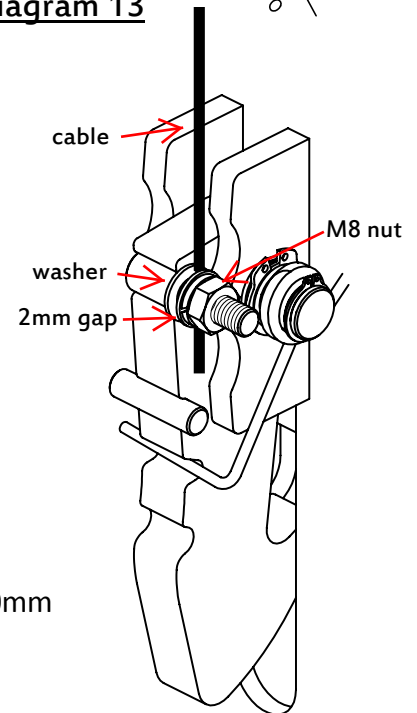

Diagram 15

Hydraulic Connections

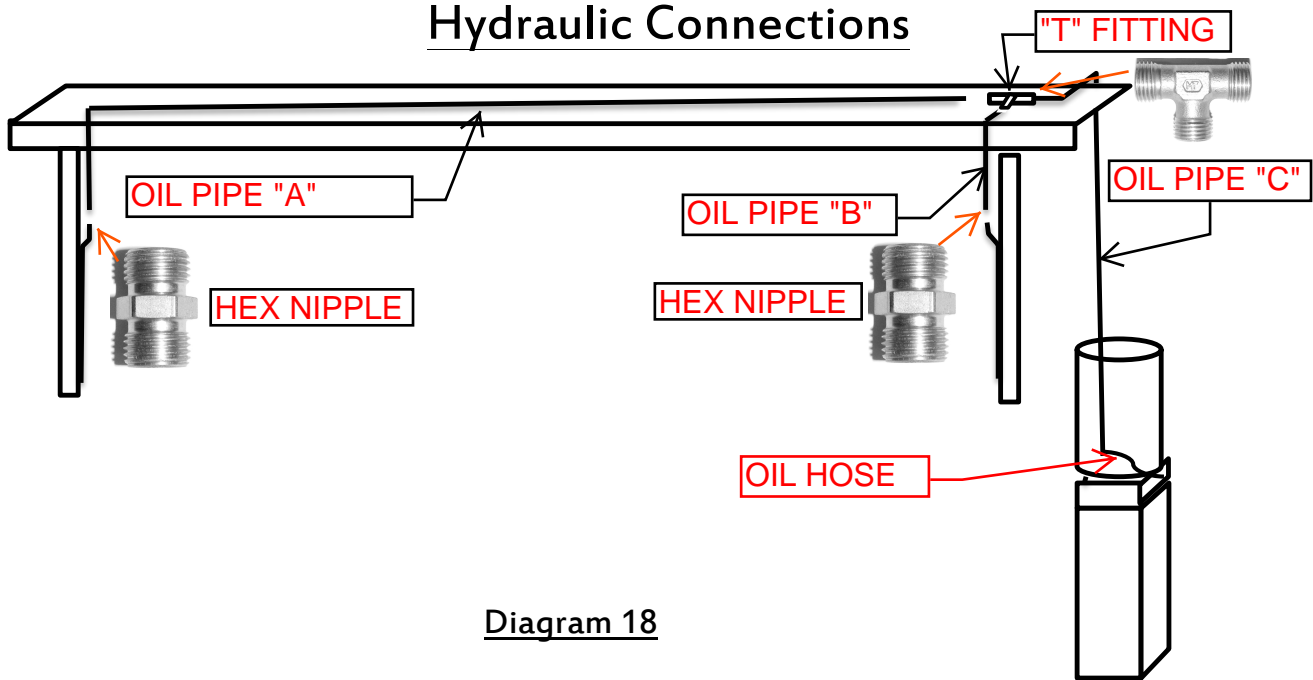
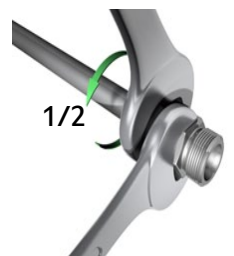

Diagram 18

1. Remove the plastic plugs from the hydraulic line connected to the side of each hydraulic cylinder.
IMPORTANT lightly grease all threads of hydraulic fittings before connecting and only tighten until hand tight until all fittings are properly connected.
2. Fit hydraulic pipe (B) through the hole in the top brace bracket and post top cap on the control post. Connect the hydraulic pipe on the hydraulic cylinder using a hex nipple.
3. Connect the motor hydraulic pipe (C) and hydraulic pipe (B) with the "T" fitting at the top of the control post. Place the long top brace hydraulic pipe (A) onto the top brace with the short bent end going down the top brace bracket and post top cap on non-control post. Connect the hydraulic pipe (A) to hydraulic pipe (B) & (C) at the "T" fitting.
4. Connect hydraulic (A) to the hydraulic pipe located on the hydraulic cylinder in the non control post using a hex nipple.
5. Remove the power pack from the cardboard box and mount to the control post mounting bracket using 4 x M8 x 20mm mounting bolts, M8 washers (2 per bolt) and M8 nuts and tighten using 1/2" open ended spanner.
6. Fit control post cover mounting bracket to the control post using 2 x M6 x 10mm screws. (Diagram 16)
7. Remove the hex nipple with the rubber "O" ring from the flexible hydraulic hose. Remove the plastic plug from the side of the power pack and fit the hex nipple with the rubber "O" ring into this port and tighten. (Diagram 19)
8. Connect the elbow fitting on the flexible hydraulic hose to the hex nipple just installed and the straight fitting of the flexible hydraulic hose to hydraulic pipe (C) hanging down the control post.
9. For all fittings firmly hand tighten, then tighten a further 1/2 turn **EXACTLY**.

NOTE when re-assembling fittings, re-apply the same torque.



10. Ensure the hydraulic cylinders have not twisted when tightening the hydraulic pipes. If so, loosen the hydraulic pipe fittings at the hydraulic cylinders and realign the hydraulic cylinders. Retighten the fittings as described in step 9.
11. Remove the filler cap from the powerpack and fill with min 8 litres of specified hydraulic oil. Refit the filler cap.

Wiring and Electrical

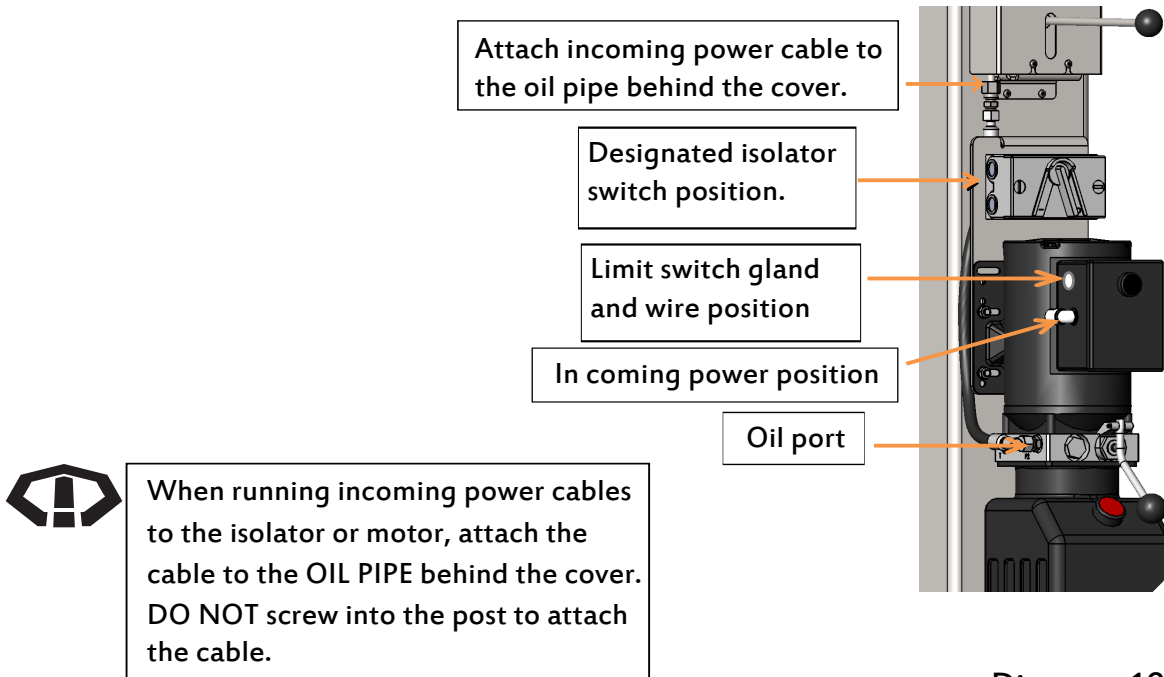

Diagram 19

1. Fit the 22mm rubber grommet into the 22mm hole at the top of the control post.
2. Mount the "P" Clip to the safety release pulley bracket with the 8x15mm tek screw.
3. Mount the limit switch using 2 x M4 X 35mm bolts as shown. (diagram 23)
4. Remove the 16mm cable gland from the limit switch wiring loom , feed the limit switch wiring loom through the "P" clip situated on the limit switch activating bracket, then feed the limit switch wiring loom through the 22mm rubber grommet and then through the "P" clip just fitted to the safety release pulley bracket and run down the motor hydraulic pipe (C).
5. Fit the 16mm cable gland to the position indicated on the power pack. (diagram 17)
6. Remove the contactor from the power pack control box. Remove the red wire between terminal A1 and the push button switch. (Diagram 18)

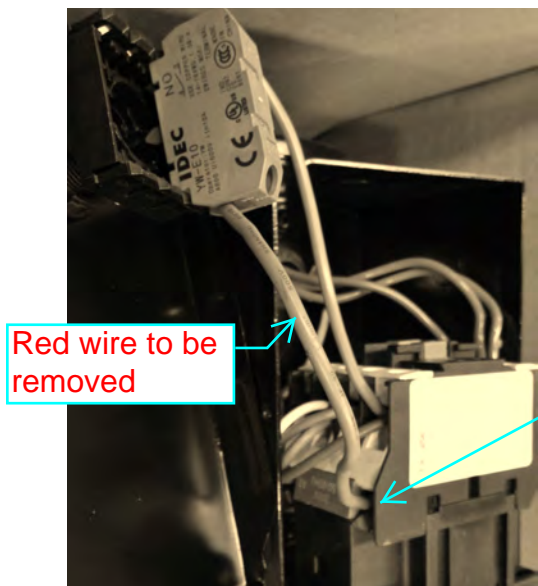

Diagram 20

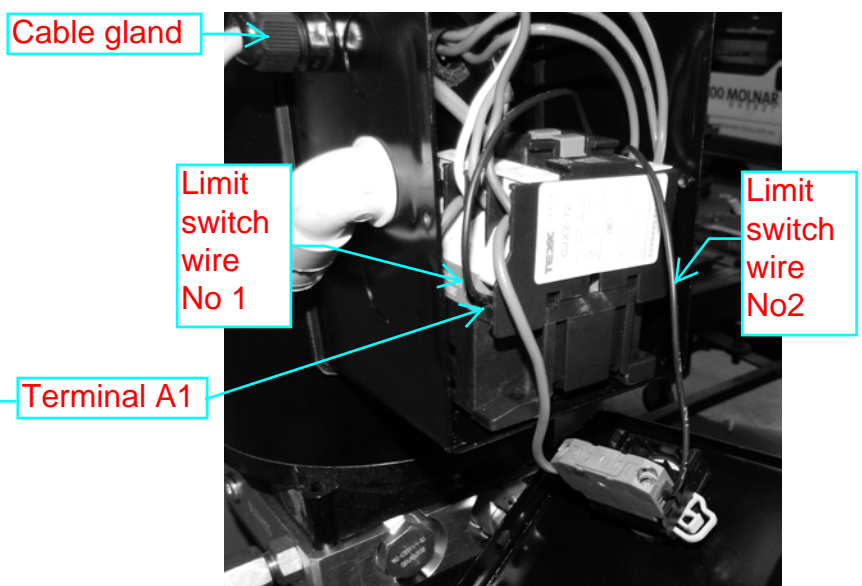

Diagram 21

7. Feed the limit switch wiring loom through the 16mm cable gland into the power pack control box.
8. Connect wire No1 to terminal A1 and wire No 2 to the push button switch. (Diagram 19)
9. Using a licensed electrician, run the incoming power wire down the face of the control post, secure limit switch wiring loom and incoming power wire to the motor hydraulic pipe (C) using the cable ties provided. Connect the incoming power wire to the contactor at terminals L1,L3,L5 and earth wire to the earth screw.
10. Fit the top sensor bar hook into the sensor bar bracket on the non-control side of the hoist. The control side of the sensor bar has a 12mm hole which should be placed around the nut fitted to the limit switch activating bracket, fit the flat washer, fit and tighten the M6 nylock nut.

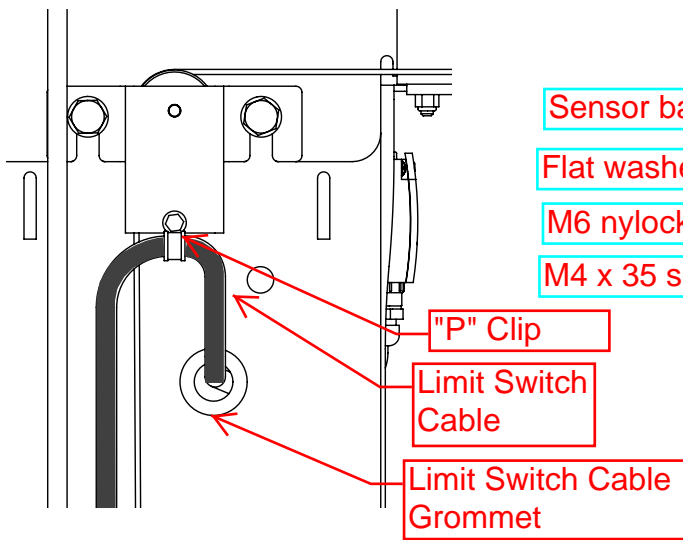

Diagram 22

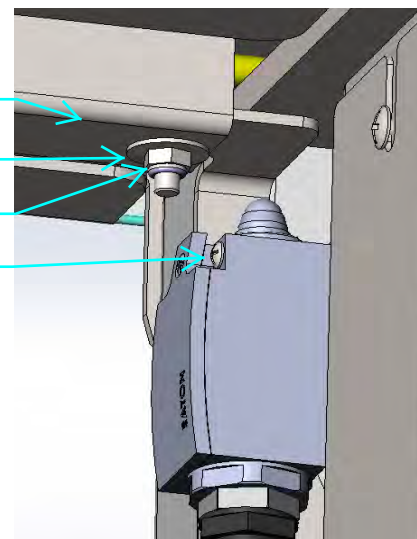
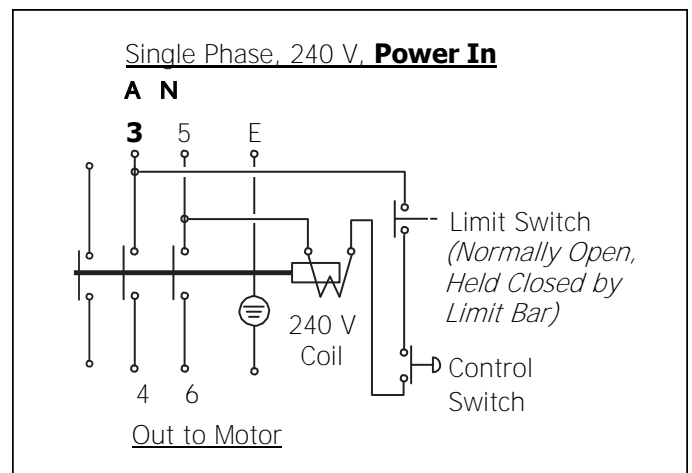
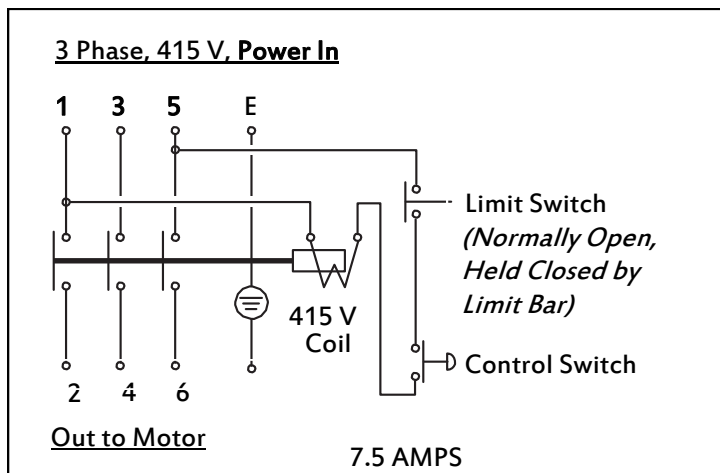
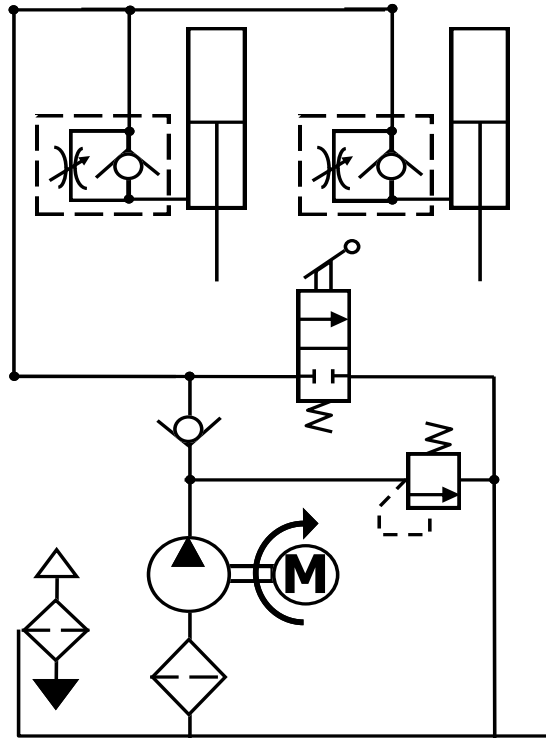

Diagram 23

Wiring Diagrams



Hydraulic Circuit



Lift Arms

1. Remove the circlip from the top of the arm pivot pin, remove the arm pivot pin from the lift arm. If you can't remove the arm pivot pin, loosen the 4 bolts on the lift arm safety teeth. Note: The long lift arms are fitted to the rear of the hoist and the short lift arms are fitted to the front of the hoist. (diagram 22)
2. Raise the lock arm release handle on the carriage and place a 50mm narrow spacer between the lock arm release handle teeth and the carriage to enable fitting. Fit the lift arm onto the carriage, insert the arm pivot pin from the bottom of the lift arm, through the carriage and then through the top of the lift arm, fit the circlip, and remove the 50mm spacer. If the arm pivot pin does not slide through the lift arm safety teeth, loosen the arm safety teeth bolts.
Note: Please ensure that the teeth on both the top and bottom safety plates are aligned together; tighten all safety teeth bolts to 43Nm after circlip has been refitted.
3. Check the arm locks are working correctly in several positions of the arms.



Non-control post
Long arm

Non-control post
short arm

Control post
short arm

Control post
Long arms

Diagram 24

Balance Cable Adjustment

Note; this procedure must be followed exactly to ensure the correct amount of tension on the cables. If cables are too loose the vehicle could become unstable and if too tight damage to the cable could occur.

1. Raise the hoist 50mm off the locks and release the safety locks and lower the hoist to within 120mm of the bottom.
2. Using 2 of the 90mm pad adjusters, place between the carriage and base plate. Lower the hoist until carriages are sitting on the adaptors. (Diagram 23)
3. On the control side, hold the cable swage at the top of the safety rack (the swage is a hex and will take a 14mm open-ended spanner) tighten the cable nylock nut (24 mm deep socket and ratchet) until the pad adaptor under the non-control carriage IS JUST MOVABLE
Note if the hoist is a high model, continue to wind the nut until a 2mm allen key JUST fits between the carriage and the pad adaptor. Once correct gap is set, remove the allen key.
4. On the non-control side, hold the swage at the top of the safety rack and tighten the cable nylock nut until the adaptor under the carriage on this side has stopped moving.
5. Run the hoist up and listen to the synchronisation of the lock engagement. Adjust the cable nut on the "high" side until the locks are in Unison.
6. Remove the 90mm pad adaptors

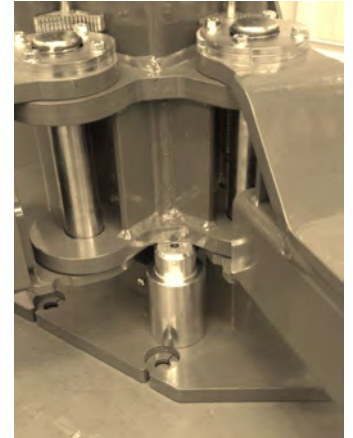

Diagram 25

Lubrication and Hydraulic Bleeding

1. Raise the hoist to the top position
2. Apply a light coating of grease, if necessary, to the shaded areas (diagram 24)
3. Lower hoist and apply a light coating of grease to the areas indicated.
4. With the hoist fully lowered, keep the lowering handle open for approx. 2 minutes to allow the air to be expelled from the hydraulic system
5. Apply a light coat of Lanotec H/D lanolin to the balance cables

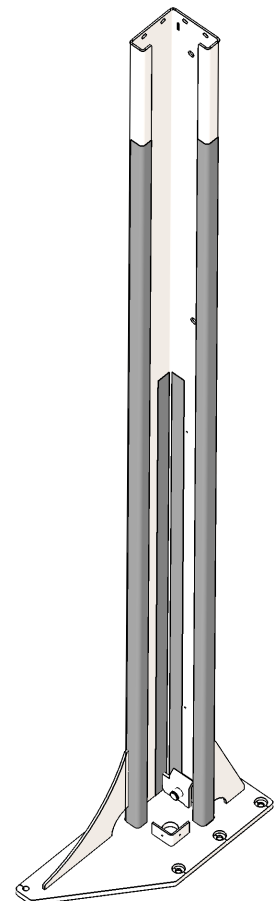
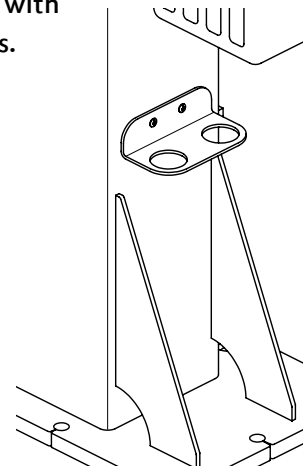

Diagram 26

Covers

1. Fit the post covers by inserting the hooks on the post covers into the slots in the face on both posts, slide down and secure with 2 x M5 x 10mm screws onto the control and non control post cover brackets.
2. Fit the black knob to the safety release handle on the control post.
3. Raise the hoist up to the 1st position lock, remove the M5 x 10mm screws from the cylinder cover bracket, feed the bottom cylinder cover through the carriage from the top of the carriage (slotted end first) and slide onto the bottom M5 x 10mm screws fitting screws at the base of the post. Secure the cylinder cover to the cylinder cover bracket with the M5 x 10mm screws, tighten all screws.
4. Fit the top cylinder cover, slide the slotted end of the cylinder cover onto the M5 x 10mm screw located on the post top cap, secure the cylinder cover to the cylinder cover bracket first, tighten all screws.
5. Fit the height extension holders to the front of the posts and secure with 2 X M6 screws per post. Place the height extensions in to the holders.



Commissioning

1. Operate the hoist through 3 complete cycles with no load on the hoist, ensuring the limit switch activates correctly.
2. Inspect the hoist for any oil leaks
3. Put a vehicle on the hoist and run the hoist through 3 full cycles.
4. Ensure the locks are engaging correctly when raising the hoist and disengaging when lowering the hoist. Ensure the hoist is smooth in operation.
5. Check the hoist for any oil leaks.
6. Clean the hoist and the surrounding area.
7. Instruct owner/operator on the operation and maintenance requirements of the hoist.

Installer Checklist

Installer must complete (tick) the following list after installing this Molnar hoist

- legal clearances around hoist
- floor is suitable and within manufactures specifications
- wire ropes, pulleys and/or hoses are free of any damage
- safety devices, limit switches and controls have been checked for correct operation
- hydraulic system checked and leak free at time of installation
- hoist tested without and with load as per manufactures specifications
- hoist has been lubricated and adjusted as per manufactures specifications
- log book use has been explained to owner/operator and initial details completed
- the client representative has been shown and instructed in the correct operation and maintenance of the hoist

Distributor (vendor)

Company

Branch

Hoist

Installation date

Model Number

Serial number

Client representative

Name

Position

Signature

Installer details

Name

Company

Signature

These records should be retained for administrative and warranty assistance

Log books are available from Molnar Services or Molnar Hoists distributors



For more information, please contact us or your local Molnar Representative

16-20 Coglin Street Brompton SA 5007 Australia
T 08 7120 8700 **F** 08 8346 0097 **E** info@molnarhoists.com.au
www.molnarhoists.com.au

onwards & upwards

Updated December 2016