

MOLNAR

4 TONNE

2 POST

CLEAR FLOOR HOIST

MODEL 2P4T- PREMIUM

Series 11

**INSTALLATION, OPERATION &
MAINTENANCE MANUAL**

Revision "B" May 2010

OPTIONAL 240 VOLT SINGLE PHASE

MINIMUM REQUIREMENTS FOR ELECTRICAL CONNECTION OF MOLNAR HOISTS

Important: All installations should be carried out by suitably qualified persons. Failure to comply may void warranty.

The following information is a guide only based on the latest standards as set out in AS/NZS 3000, for installations outside of Australia and New Zealand refer to local standards/regulations.

Circuit breakers should be of "D" curve type (motor start, high inrush current). Ratings given as a maximum for circuit & motor protection based on DOL selection guide.

Voltage operating range: -6% to +10% of motor nameplate voltage.

Motor Voltage 240 V, operation range 225V to 264V.

Cable sizes are given as a guide only for a maximum cable length to 30 M. Longer cable runs and in areas where supply voltage is below motor voltage, calculation should be made to ensure Voltage Drop will not fall below minimum operating voltage.

**When installed motors must be tested under Full Load checking
Voltage at motor terminals.**

Motor: 2.2Kw 240 V single phase, model CWC 3640F.

Full Load Current: 12.4 Amps

Min Cable Size: 2.5mm 2 core + earth

Circuit Breaker: 1 phase 32 Amp 10Ka

Recommended Clipsal 4CB132/10 or equivalent.

No person should be permitted to operate the MOLNAR CLEAR FLOOR HOIST without first studying the operating instructions on page 6 and safety precautions on page 10.

This Manual should be kept in a safe place and referred to as necessary.

The installation requirements on page 23 must be completed and the certificate on the inside back cover must be signed by the installer. The guarantee card must be completed and returned to MOLNAR ENGINEERING PTY. LTD.

When installed in tropical environments it is advisable to raise the hoist to full height when not in use overnight or on weekends, to minimise condensation forming inside the cylinder which may lead to corrosion of cylinder bore.

This vehicle hoist is not designed to be used for steam cleaning nor to be installed in the open exposed to the elements. Vehicle hoists installed under such conditions are not covered by our guarantee.

CONTENTS

| | |
|---|-----|
| SPECIFICATIONS | 2 |
| INTRODUCTION | 3 |
| INTRODUCTION | 4 |
| FLOOR REQUIREMENTS FOR MODEL 2P4T | 5 |
| OPERATING INSTRUCTIONS | 6 |
| OPERATING INSTRUCTIONS | 7 |
| MAINTENANCE | 8 |
| MAINTENANCE | 9 |
| LUBRICATION PROCEDURES FOR MOLNAR 2 POST HOISTS | 9 |
| SAFETY PRECAUTIONS | 10 |
| FAULT CHART | 11 |
| HYDRAULIC CYLINDER REPLACEMENT | 12 |
| WIRING DIAGRAM | 13 |
| HYDRAULIC CIRCUIT DIAGRAM | 14 |
| INSTALLATION INSTRUCTIONS | 15 |
| INSTALLATION INSTRUCTIONS | 16 |
| INSTALLATION INSTRUCTIONS | 17 |
| INSTALLATION INSTRUCTIONS | 17 |
| INSTALLATION INSTRUCTIONS | 189 |
| INSTALLATION INSTRUCTIONS | 20 |
| INSTALLATION PROCEDURE | 20 |
| ARM LOCK PARTS LIST | 21 |
| DOOR PROTECTOR INSTALLATION PROCEDURE | 22 |
| INSTALLATION PROCEDURE | 22 |
| INSTALLATION REQUIREMENTS | 23 |
| BETABITE HYDRAULICS ASSEMBLY INSTRUCTIONS | 24 |
| CERTIFICATION | 26 |

SPECIFICATIONS

| | | |
|--------------------------------|--|-----------------|
| Width between columns | | 2650mm |
| Overall width | | 3450mm |
| Overall height | | 3850mm |
| Overall length | | 1000mm |
| Maximum raised height | | 1900mm |
| Minimum lowered height | | 115mm |
| Length of lifting arms maximum | | 1020mm |
| Length of lifting arms minimum | | 610mm |
| Lifting time (working height) | | Approx. 30 secs |
| Electric motor | - 3 phase, 2.2kw, 2700 rpm, 415 volts, 50 hertz | |
| (optional) | - Single phase, 2.2kw, 2850 rpm, 240 volts, 50 hertz | |
| Hoist mass | - 960kg | |
| Wire rope | - 13mm diameter 6 x 29FW(14/7+7F/1) IWRCRHOL | |
| | B1770 minimum breaking strength 107kn | |
| Hydraulic oil | - Castrol Hyspin AWH46, Shell Tellus T46, Mobil DTE | |
| | 25, BP Bartran HV46 or equivalent | |
| Capacity | - 4000kg (4.0 tonnes) | |

The Manufacturer reserves the right to alter these features and specifications without notice.

INTRODUCTION

Here is the MOLNAR CLEAR FLOOR HOIST, a space saving wheel-free hoist and its many advantages.

It has been purposely designed for space saving and to give versatility and profitability to the largest garage and smallest service station. Safe, strong, simply built to give years of trouble-free service. The MOLNAR CLEAR FLOOR HOIST embodies many features that make it the most up-to-date equipment for quicker and more profitable service.

SAFE AND EFFICIENT OPERATION

Molnar Hoists use an electro hydraulic system which gives years of trouble free service. Raising and lowering of vehicle is controlled by hydraulics, plus built-in mechanical safety against any failure together with “deadman” controls.

INSTALLATION

The MOLNAR CLEAR FLOOR HOIST PREMIUM is fast and simple to install only 16 expanding sleeve anchors are needed for a suitable floor. No costly excavation. It is also ideal for upper floor level where excavation is not possible. The hoist is surface mounted a feature which means lower overall cost. Compared with similar-priced hoists the MOLNAR CLEAR FLOOR HOIST can be quickly, easily and economically re-sited.

INTRODUCTION

FOR SPEEDIER SERVICE

With the MOLNAR CLEAR FLOOR HOIST maximum accessibility is assured. No cumbersome beams or cross-sections impede the operator in any way, giving the hoist unlimited advantages, when used for unit replacement. With this lifting method the suspension springs are relaxed, facilitating lubrication and repair work. Wheel service, brake adjustment, washing underbody spraying or sealing or any underbody repairs can be speedily carried out.

EASY TO OPERATE

The MOLNAR CLEAR FLOOR HOIST is operated with the greatest of ease. The telescopic adjustable arms and contact pads are easily placed in position by one man. The operator has full confidence due to the mounting of the arms and the area of the chassis which can be contacted. The vehicle is immediately wheel-free and stable at any height.

FLOOR REQUIREMENTS FOR MODEL 2P4T

These notes are for your guidance prior to installation.

1. It is the users responsibility to provide a satisfactory site area.
2. The floor should be a single reinforced concrete slab.
 - Min concrete thickness = 100mm
 - Min plan dimensions of 4600mm x 1800mm
 - Prepared base 100mm thickness of quarry rubble compacted to 95%
 - SL81 reinforcement mesh
 - Min thickness of concrete above mesh = 65mm
 - 25Mpa concrete
3. For correct installation of the Clear Floor Hoist the floor must be flat and level. A level tolerance between posts of 10mm is allowable. Check with straight edge and spirit level. (Ref. Fig. 1).
4. Recommended anchor bolts are expansion sleeve type anchors 20mm diameter with a minimum length of 82mm. Use the manufacturers recommended installation procedures.
NOTE: Some authorities do not approve expanding type anchorage devices.
5. If there is any doubt about the quality of the floor, a replacement slab should be installed. Use a qualified person to design the replacement slab.
6. No liability for any damages will be accepted should you install the hoist on an unsuitable floor.

OPERATING INSTRUCTIONS

1. Position vehicle central to the hoist posts.
2. Place the four pads under the vehicle at vehicle jack points.
3. Raise the vehicle with the hoist until the wheels have just left the ground and check that the load is balanced, stable and the pads are located correctly. If not correct lower vehicle to the ground and reposition vehicle and pads as necessary and check again.
4. Press starter button and raise vehicle to required height. Do not go under vehicle until load rests on safety.
5. When vehicle reaches maximum height limit switch will come into operation and stop hoist. When hoist has stopped, pull release lever until load rests on safety.
6. Before lifting, the safety lever should be in the "ON" position. During lifting with the automatic safety "ON" a clicking sound should be noticeable, this indicates the safety mechanism operating. If this sound is not heard, immediately cease using the hoist and call an authorised service agent.
7. When the required height is reached, stop the hoist, ensure the safety lever is in the "ON" position and then lower load until safety mechanism pawl comes to rest on a ratchet tooth and supports the load together with the wire ropes.
8. To lower the hoist, first raise it approximately 20mm, push the safety lever to the "OFF" position and pull the release lever down.

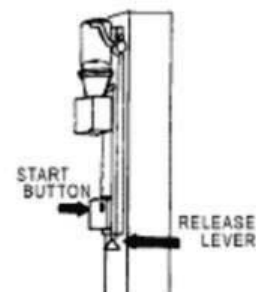
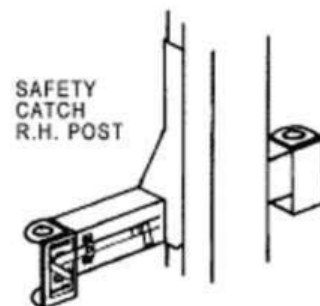
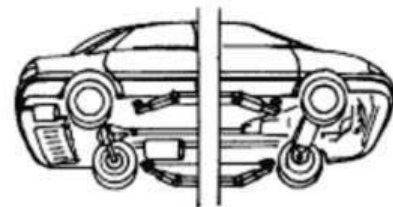
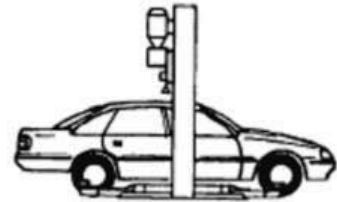

OPERATING INSTRUCTIONS

9. If the car is to be worked on at an intermediate level, load must be once again secured as detailed in step 7.
10. **WARNING:** Do not go under the vehicle under any circumstances while the vehicle is being raised or lowered.

MAINTENANCE

CHECK DAILY

1. Check safety mechanisms to see that they function properly.
2. Check arm locks are working correctly.
3. Check condition of lift pads.

CHECK MONTHLY

1. Safety mechanisms operation.
2. Condition of sheaves, shafts and shaft locks.
3. Condition of wire ropes.
4. Overall cleanliness.
5. Clean tracks of dry lubricant and re-apply lubricant on roller tracks.

CHECK 3 MONTHLY

- 1 Check balance cables Refer point 20 of installation instructions.

CHECK 6 MONTHLY

1. State of swivel arms.
2. Oil leaks from cylinders.
3. Oil leaks at pipe joints.
4. Anchor bolts.
5. Wire ropes.

NOTE: Refer to trouble shooting chart, page 11, for fault remedies.

YEARLY

Service and safety inspection on the hoist must be performed by a competent person. This inspection must be recorded. If the 12 monthly service and safety inspection is not performed, the warranty is null and void.

NOTE: Yearly service must include removal of rollers and pulleys to inspect, clean and lubricate bushes and pins.

2 YEARLY

Hydraulic oil and filter should be replaced. Fill Oil Tank to Oil Level Line with Shell Tellus T46 oil, Mobil DTE25 oil, Castrol Hyspin AWH46 oil, BP Bartran HV46 oil or equivalent.

MAINTENANCE

2 YEARLY

Wire ropes must be inspected by a COMPETENT person. Inspect for wear, rust and broken wires. Ropes are to be discarded according to the criteria.

Wire rope must be replaced if:

- a. At any point the visible number of broken wires exceeds 10 in any length equivalent to 20 times the rope diameter i.e. for 13 mm diameter rope 10 broken wires in 260mm of cable.
- b. A strand of wire is broken.
- c. A rope has been physically damaged by crushing or deforming.

LUBRICATION PROCEDURES FOR MOLNAR 2 POST HOISTS

It is the Hoist Owner's responsibility and Duty of Care to maintain the Hoist as per the Maintenance Schedule in the Hoist Owner's Manual.

All tracks must be lubricated regularly. (Both Posts.)

This includes the roller tracks behind the covers. (Both Posts.)

Molnar Engineering suggests industrial grade silicone based aerosol type sprays may be used (because the Hoist will be totally clean and there is no fear of lubricant accidentally being rubbed on clothing).

Molnar Engineering suggests that the rear tracks be heavily lubricated. You may use grease on the rear tracks because the rear tracks are fully covered by the hoist covers.

"TAC 2" lubricant may also be used.

SAFETY PRECAUTIONS

DON'T

1. Do not try to lift anything beyond the maximum capacity 4000Kg.
2. Do not operate without first ascertaining the safety of people and equipment in the area.
3. Do not go under car or make adjustments while hoist is in operation.
4. Do not try to adjust bearer pads engaged to jack points while the hoist is in operation.
5. Do not fail to inspect safety devices periodically to see they are in proper working condition.
6. Do not make unauthorised changes to safety equipment. In emergency consult this manual or your local dealer.
7. Do not oil or grease swivel arms as they should not move in or out while hoist is operating.
8. Do not fail to protect operating switch from water if the hoist is used for car washing. Ropes should be smeared with water resistant grease.
9. Do not try to adjust relief valve as it has been set at maximum operating efficiency.
10. Do not turn off mains power while hoist is operating.
11. Do not force safety lever into the off position while weight is resting on safety.
12. Do not attempt to operate the hoist from under vehicle.
13. When lifting vehicles with loads care should be paid to load distribution and pad position as the load may become unstable with removal or fitting of components to vehicle. If in doubt perform a risk assessment on the vehicle before lifting.

FAULT CHART

| FAULT | PROBABLE CAUSE | REMEDY |
|---|--|--|
| Noise from rollers. | Lack of lubrication on roller tracks and roller pins. | Lubricate roller tracks and roller pins with industrial grade aerosol based silicone spray. |
| Noise from pulleys. | Lack of lubrication on pulley pins. | Lubricate pulley pins as above. |
| Leakage of oil at joints. | Loose fittings. | Inspect the piping and tighten joints. |
| Leakage of oil at top of hydraulic cylinder. | Worn / damaged piston seal in hydraulic cylinder, | Replace piston seal and / or cylinder. |
| Hoist does not respond to operation switch. | Power supply to motor is interrupted. Motor turning in opposite direction.(3 phase only) Cables either cut or damaged. | Check main power source. Check that safety up stop switch is free. Refer to installing electrician. |
| Damaged cable. | Worn sheaves and sheave pins or bushes. | Replace sheaves, sheave pins and cables and bushes. |
| Carriage shuddering in lifting and lowering mode. | Lack of lubricant on roller tracks. | Clean and re-apply lubricant on roller tracks. |

HYDRAULIC CYLINDER REPLACEMENT

Procedure

1. Turn off power and isolate the hoist.

Disconnect power cables from the hoist (only to be performed by a licensed electrician).
2. Remove post covers and cable cover.
3. Make sure both carriages are fully lowered. Disconnect balance cables on both carriages.
4. Disconnect top limit switch. Slide conduit into right hand post to expose cable connectors. Disconnect the cable connectors for the top limit switch in the top cross beam. Disconnect hydraulic lines at top of post and remove.
5. Remove balance cables.
6. Remove the top cross beam.
7. Remove pulley assemblies from the top of the posts.
8. Disconnect conduit from the T-piece junction, and withdraw the two white top limit switch wires from conduit.
9. If removing right hand side cylinder disconnect hydraulic pipe from the cylinder at the power pack and gently push it back until it sits inside the post to ensure it does not snag when removed from post. Then remove the power pack from the right hand post.
10. Unbolt posts and lay down with the exposed sheaves facing upwards.
11. Disconnect twin cables from carriage and remove pulley assembly from the top of the cylinder.
12. Disconnect cylinder locator at the top of the cylinder and disconnect pipe locator. Ensure hydraulic pipe disconnected is inside the post (refer to step 8) and then slide cylinder/pipe out of post.
13. To remove piston take out circlip and apply compressed air to inlet (with caution). Inspect cylinder wall for rust or scoring. If scored the cylinder wall must be re-honed or the malfunction will continue. If rusted it must be re-honed or replaced.
14. Reassemble in reverse order.

WIRING DIAGRAM

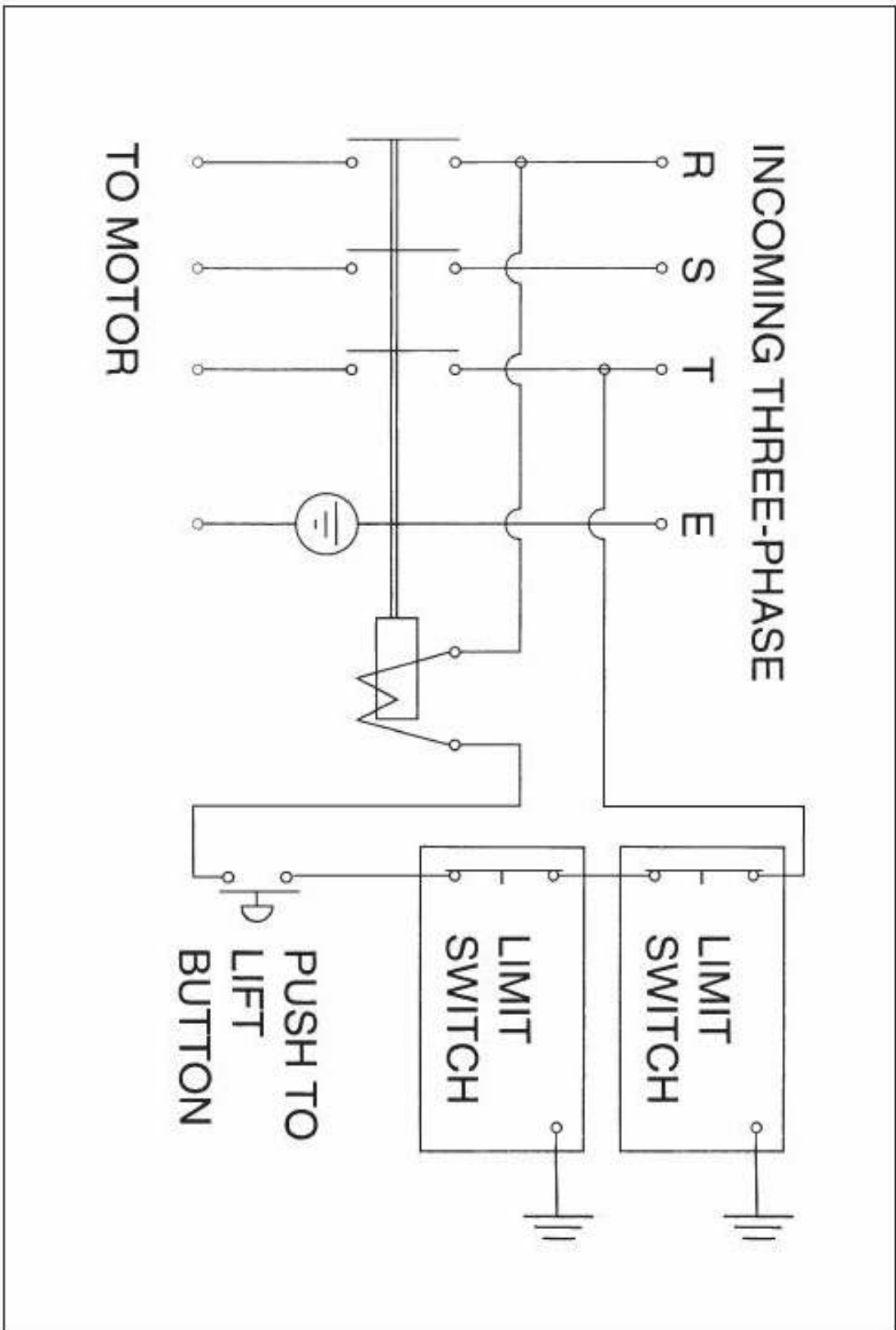

WIRING TO THIS UNIT TO COMPLY WITH AS 3000

HYDRAULIC CIRCUIT DIAGRAM

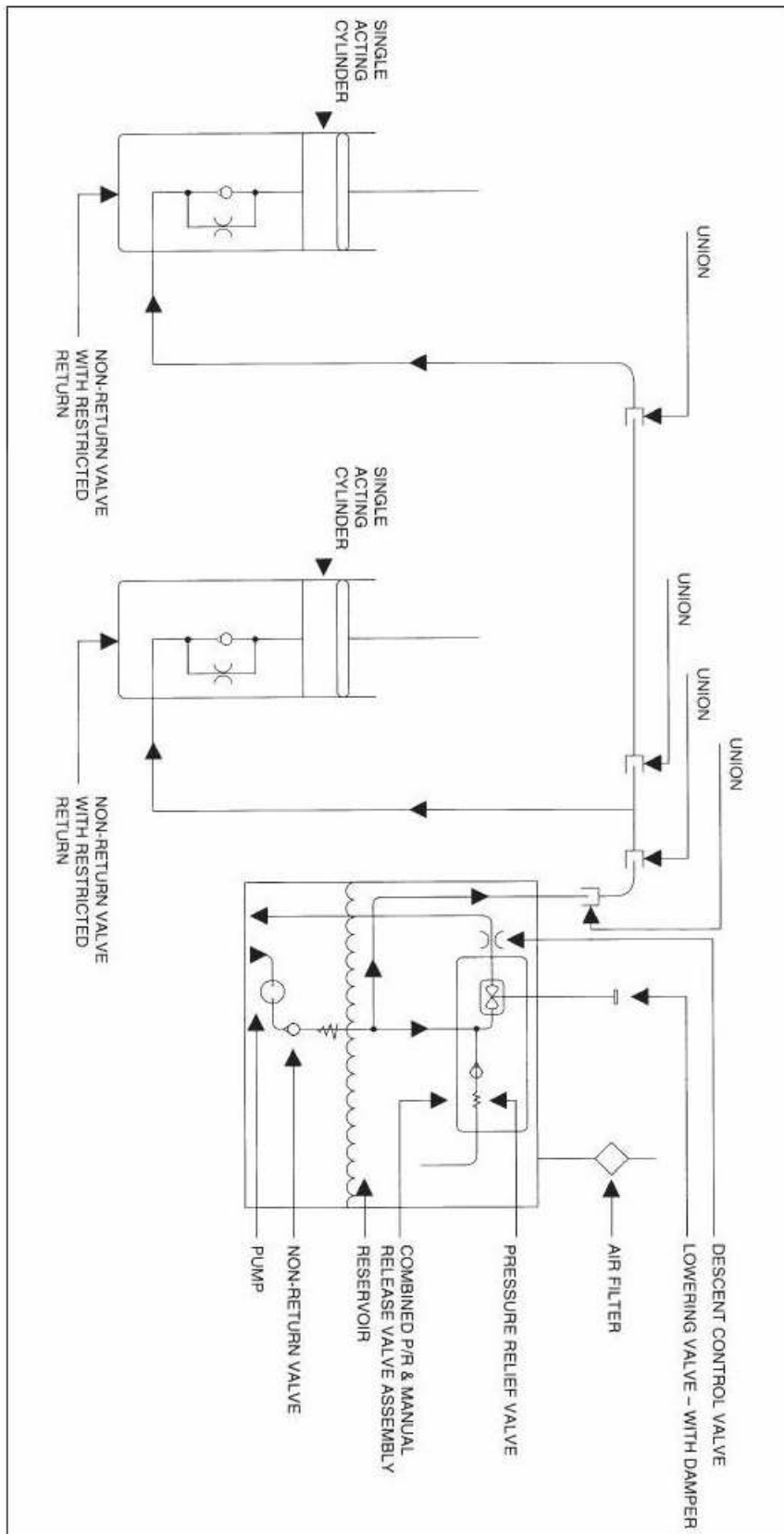

INSTALLATION INSTRUCTIONS

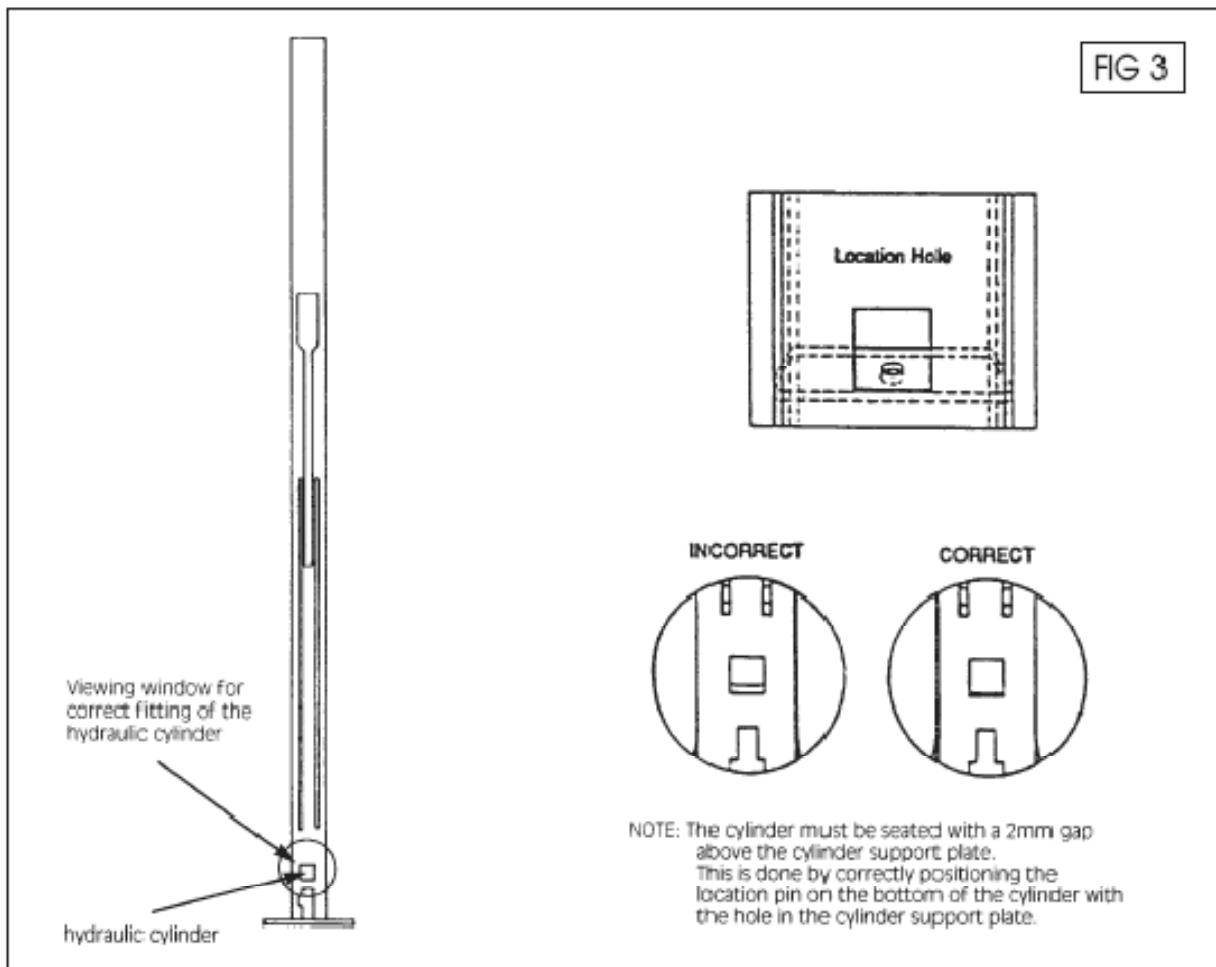
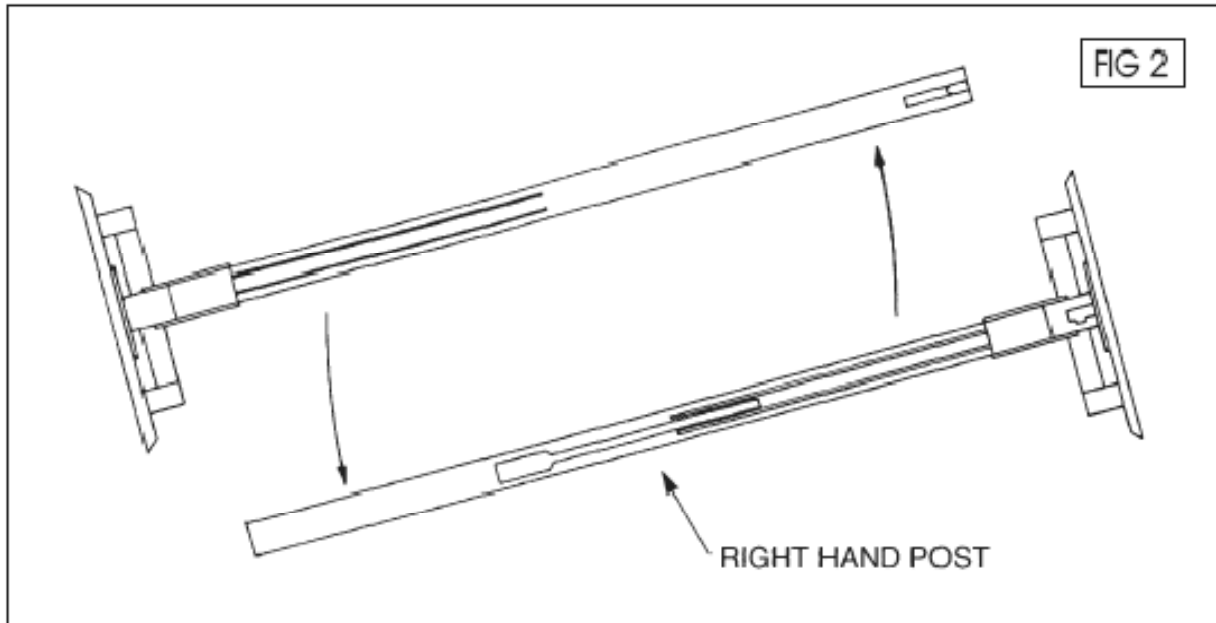

INSTALLATION INSTRUCTIONS

1. Position hoist to installation position on two bearers with packing legs approximately 20-50mm above the ground.
2. Remove packing legs.
NOTE: The packing legs securing bolts (3 per side) are to be fitted into the base plates of the posts. The leftover packing nuts and bolt from each side are to be discarded.
3. Remove wooden crates. Open crates and lay out contents.
4. Remove lifting arms.
5. Cut straps holding posts and remove wooden protectors from posts.
6. Swing out top of both posts, horizontally anti-clockwise right hand post first and place on wooden blocks. Refer figure 2.
7. Remove balance cables from inside each post. "Top end".
8. Pull conduit through the hole on the face of right hand post.
9. Remove pulleys from support beam brackets NOTE: 1 Bracket has hole for conduit must go to motor post. Fit brackets to posts. Fit balance cable through brackets and refit pulleys ensuring shims are fitted correctly to side of pulleys.
10. Ensure cable is tightly seated in sheave groove at the bottom end of both posts whilst raising posts into upright position.
11. Check cable positions when each post is in upright position.
12. Position right hand post and bolt down one outside fastening lug.
Recommended anchor bolts are expansion sleeve type anchors 20mm diameter with a minimum length of 82mm.
13. Position left hand post 2650mm from right hand post then repeat step 11.
14. Place top cross beam on top of beam support brackets.
Secure each side with bolts provided.
15. Check distance between bottoms of posts is 2650mm.
16. Check posts are square to each other, adjust accordingly.
17. Check that posts are vertical. Shim as required under frame of base.
18. Bolt left hand and right hand posts down.

INSTALLATION INSTRUCTIONS

19. Fit the cable to the opposite side pulley assembly and locate pulley assembly onto the top of the post. Ensure cables are not crossed over through top beam.
20. Fit balance cables loosely to the carriages
21. Cut the straps marked "DO NOT CUT THIS STRAP UNTIL THE POST IS IN AN UPRIGHT BOLTED-DOWN POSITION".
22. Place power pack on motor post. Feed limit switch wires through conduit in post, connect at top.
23. Connect hydraulic pipe leading from the cylinder. Ensure all hydraulic fittings are tight. Connect oil pipe between both posts. See page 24 for Betabite Hydraulics assembly instructions, refer figure 10.
24. Attach limit switch activating bar to the top crossbeam. Refer figure 6&7.

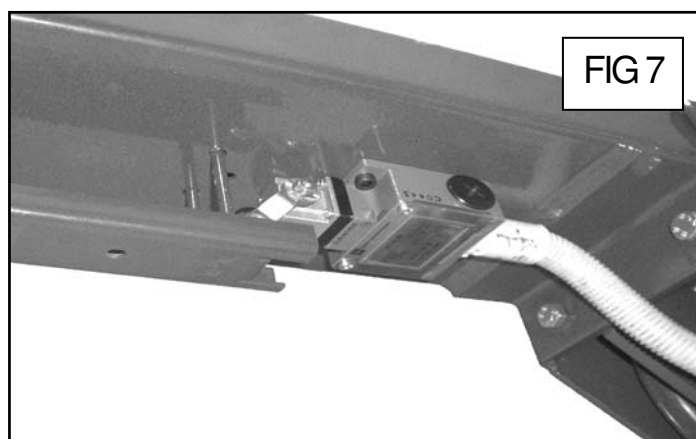
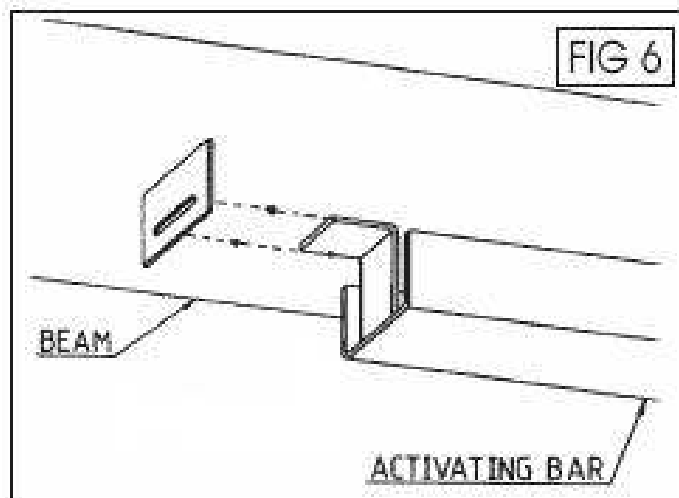

INSTALLATION INSTRUCTIONS

25. Pour oil into the tank. Oil to be filled through breather vent. Connect power (only to be performed by a licensed electrician).
26. IMPORTANT. Check that all cables are seated correctly in pulley grooves.
27. Adjust Balance cables.
 - Step1: Raise hoist manually to waist height, lower on to safety locks.
 - Step 2: Make sure the left carriage is locked in at the same height as the right carriage. It may be necessary to loosen the balance cables in order to set carriages at same level,
 - Step 3: Tighten the nut on the right hand carriage until the safety toggle has risen 10-13mm above the tooth.
 - Step 4: Tighten the nut on the left hand carriage until the safety toggle on the right hand carriage lowers back down to the safety tooth. Then give one full turn extra.
 - Note: For a new installation this process should be repeated after the first 3 months of use, as the cables would have stretched and bedded in. (refer to Figure 5).

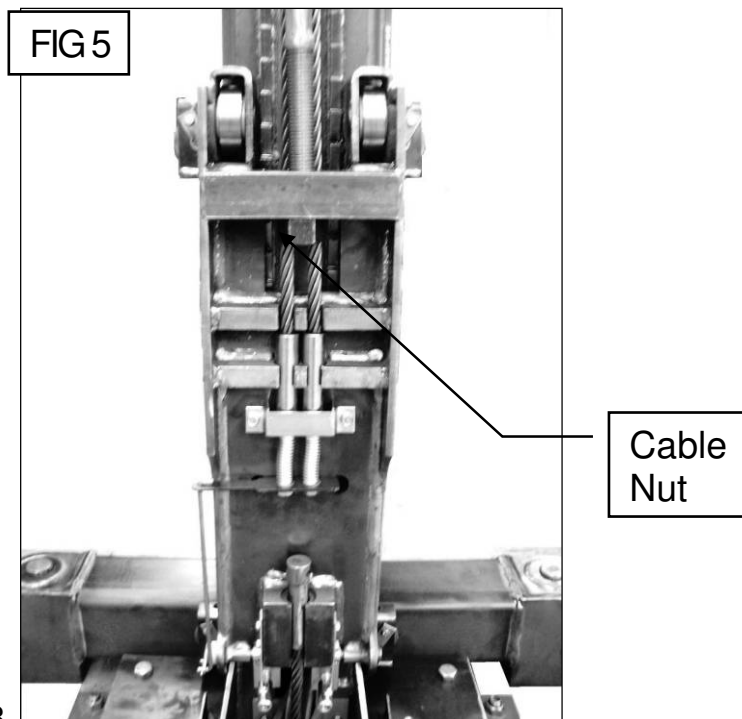

29. Check that the cylinders are seated correctly (with a 2mm gap when viewed through inspection hole above bottom right sheave). If a cylinder is not seated correctly adjust its position with bent wire until it drops into position and seats under its own weight. Refer figure 3.
30. Install lifting arms.
31. Install locking arms. See page 20 for installation instructions, refer figure 8. An Arm Lock parts list appears on page 21.
32. Bolt top cover brackets to posts.
33. Attach door protectors. See page 22, refer figure 9.
34. Apply lubricant to roller tracks. Check that the hoist is operating correctly by raising and lowering throughout range. Check that the safety is working. Check that both limit switches are working.
35. Clean the hoist of anti-corrosion spray.
36. Install covers on both posts. Install cable covers.

INSTALLATION INSTRUCTIONS

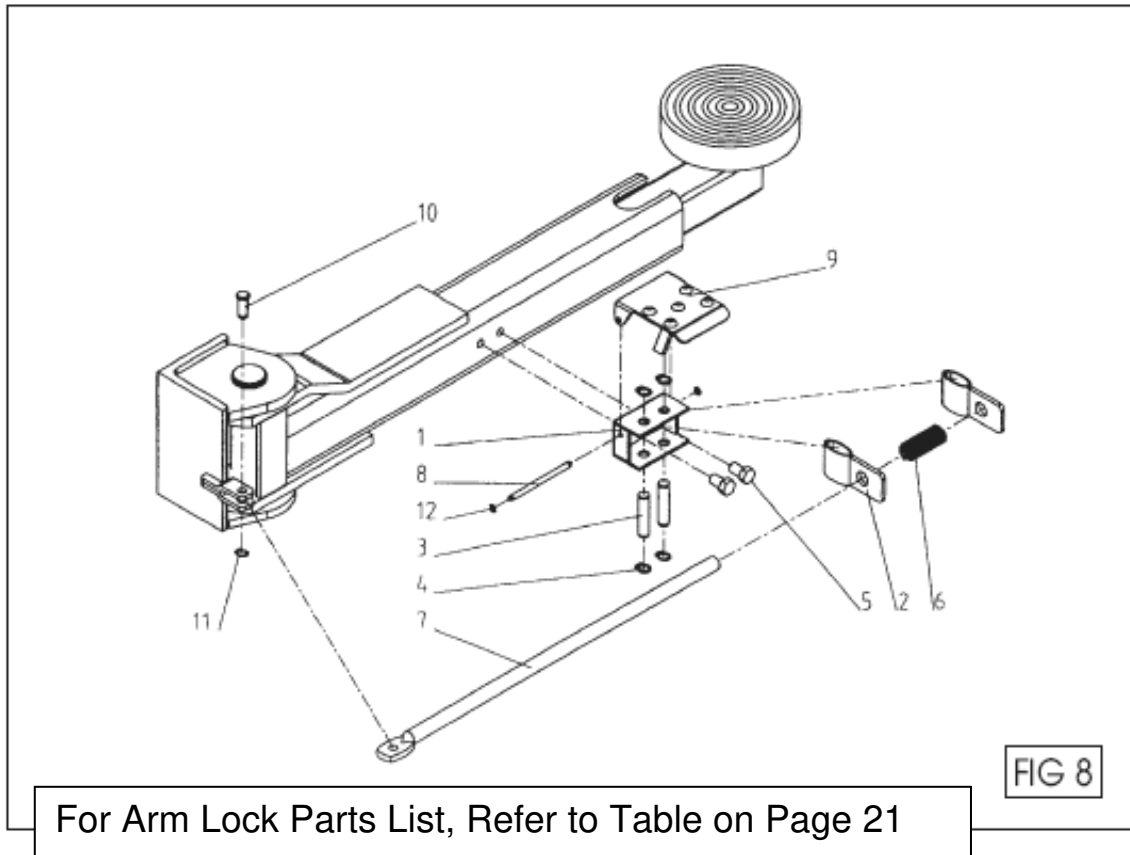

INSTALLATION PROCEDURE

1. Bolt locking bracket (1) to pick-up arm using 7/16 U.N.F. bolts.
2. Locate arm (7) in pivoting bracket.
3. Slide locking lug (2), followed by spring (6), followed by another locking lug (2), along arm (7).
4. Locate locking lugs (2) in locking bracket (1).
5. Push pins (3) into position and secure using circlips.
6. Push pin (10) into position and secure using circlip (11).
7. Place foot pedal (9) over locking bracket (1).
8. Push shaft (8) through foot pedal and locking bracket and secure with E clip (12).

ARM LOCK PARTS LIST

Refer to figure 8 for Arm Lock item numbering.

| <u>ITEM NO.</u> | <u>DESCRIPTION</u> | <u>PART NO.</u> |
|------------------------|-----------------------------|------------------------|
| 1. | Bracket Locking Arm | 2P4T-J-57 |
| 2. | Locking Plate | 2P4T-J-58 |
| 3. | Shaft Locking Plate Pivot | 2P4T-J-55 |
| 4. | Circlip 12mm (DIN 471-12) | 2P4T-J-56 |
| 5. | Bolt 7/16 UNF x 3/8" | 2P4T-J-60 |
| 6. | Spring | 2P4T-J-59 |
| 7. | Rod Locking Arm | 2P4T-J-61 |
| 8. | Shaft Foot Pedal | 2P4T-J-356 |
| 9. | Foot Pedal | 2P4T-J-354 |
| 10. | Shaft Pivot Locking Arm Rod | 2P4T-J-49 |
| 11. | Circlip 10mm (DIN 471-10) | 2P4T-J-46 |
| 12. | E. Clip 4mm | 2P4T-J-355 |

DOOR PROTECTOR INSTALLATION PROCEDURE

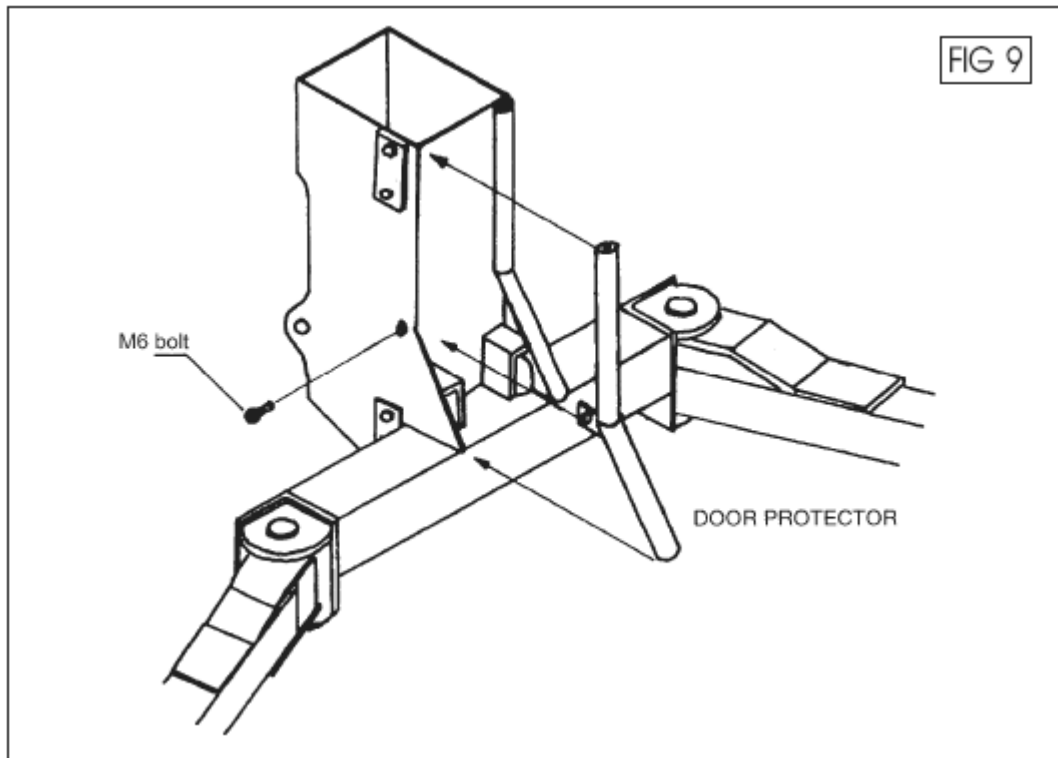

INSTALLATION PROCEDURE

1. Place door protector into position as shown in above drawing. Make sure the door protector ends are flush with the edge.
2. Push the protector in at the bend, until the holes in the bracket and the carriage line up.
3. Screw the M6 bolt into position as shown in diagram.

INSTALLATION REQUIREMENTS

INSTALLER MUST CHECK THE FOLLOWING LIST WHEN INSTALLING A MOLNAR CLEAR FLOOR HOIST

1. A suitable floor where the hoist is to be bolted down must have a level surface to ensure the hoist base frames lie flat. When the hoist is bolted down check all nuts and bolts to ensure they are all correctly tightened.
2. Check wire ropes and sheaves for possible transport damage or dislocation.
3. When power is connected to the hoist terminal box the motor must rotate clockwise. If motor rotation direction on 3 phase hoist is reversed, refer to installing electrician.
4. Check safety mechanism for loose nuts or bolts.
5. Check operation of safety mechanism on both sides, then test hoist with load.
6. Recheck hoist operation. Demonstrate the hoist to the operator.
7. **Very important;**
 - 7.1. Instruct operator how to use the hoist, how the safety mechanism works and where to place lifting pads when lifting vehicles.
 - 7.2. Point out maintenance requirements on wire ropes and that they should be checked monthly.
 - 7.3. Point out that by law, the operator and/or owner are responsible for the maintenance and safe operation of the hoist.
8. When all the above points are checked the certificate must be signed by the installer.

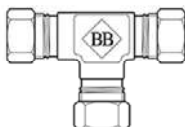

Assembly Instructions

1. Cut the tube to length and file ends square.
2. Remove internal and external burrs from tube end.
3. We always highly recommend that joints are pre-made whilst the coupling body is held firmly in a bench vice.
4. Ascertain that all the detail parts of the coupling are suitably lubricated, especially the internal body cone, the rear of the ferrule and the internal thread of the nut. The lubrication process is recommended on all fittings, however, on stainless steel couplings the use of a quality lubricant is imperative. Betalube, a copper based paste is highly recommended and available from Betabite Hydraulics or your local distributor. Please note after assembly, fittings to be used on Oxygen lines should be fully degreased.
5. Slide the nut onto the tube, followed by the ferrule, the open end of the nut should be towards the end of the tube, and similarly, the cutting or smaller end of the ferrule should point towards the tube end.
6. Present the tube, nut and ferrule to the coupling body, making sure that tube passes cleanly through the nut and ferrule & butts firmly against the step (abutment face) provided in the coupling body. Screw the nut onto the coupling body until finger tight.
7. Hold the tube in one hand and with the correct sized spanner in the other hand, tighten the nut until the ferrule is felt to just grip the tube. This point is determined by rotation or slightly rocking the tube. From this point, the nut should be tightened 1 ¼ to 1 ½ turns from the initial ring grip to obtain a fully effective cutting action. On larger sizes of fitting, an extension to the spanner is highly recommended to maximise leverage and minimise effort.
8. If the nut is now removed, the ferrule will have cut its own seating on the tube and whilst it will be found to rotate, it cannot be moved towards the tube end. The 'joint' may now be re-assembled, by re-tightening of the nut until significant resistance is felt and then increase for a further ⅛ to ¼ of a turn. The above procedure must be followed closely to ensure a safe and successful joint.
9. Betabite fittings correctly made can be broken repeatedly, when not under pressure and re-made without affecting their pressure tightness and leak-proof quality

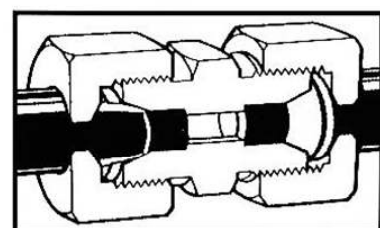
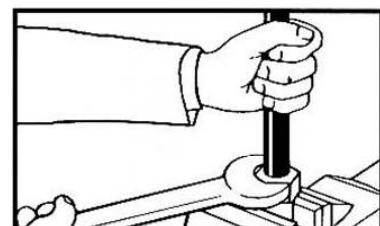
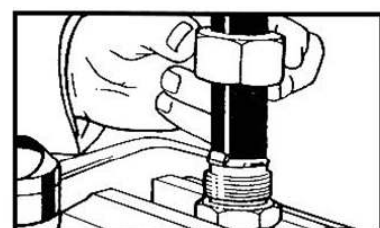
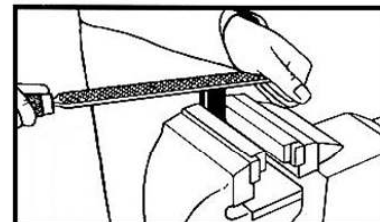

Pressure rating tables for your safety, convenience and peace of mind

| Imperial sizes | Hydraulic | Gas |
|----------------------|----------------------|---------------------|
| > 1" OD or ¾" NB | 690 bar (10,000 psi) | 345 bar (5,000 psi) |
| > 1 ¼" OD or 1" NB | 552 bar (8,000 psi) | 276 bar (4,000 psi) |
| > 1 ½" OD or 1 ¼" NB | 414 bar (6,000 psi) | 207 bar (3,000 psi) |

| Metric sizes | | |
|------------------|------------|---------------------|
| (L) Light series | 6 to 18mm | 315 bar (4,568 psi) |
| (L) Light series | 22 to 42mm | 160 bar (2,320 psi) |
| (S) Heavy series | 6 to 14mm | 630 bar (9,135 psi) |
| (S) Heavy series | 16 to 30mm | 400 bar (5,800 psi) |

www.betabite.co.uk

NOTES

CERTIFICATION

I hereby certify that the hoist has been checked and is in a safe operating condition and that the purchaser/operator has been duly instructed in the operation thereof.

Purchaser
Model No 2P4T-Premium
Serial No
Date

Installation by
Address
.
Name
Signature
Date

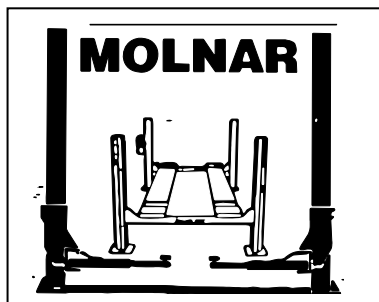

MANUFACTURED BY:

MOLNAR ENGINEERING PTY. LTD.

A.B.N. 54 007 740 794

16-20 Coglin Street, Brompton, S.A. 5007 AUSTRALIA

Telephone: (08) 8346 6893, (08) 8346 6894, (08) 8346 8006

Fax: (08) 8346 0097. Email: sales@molnarhoists.com.au

www.molnarhoists.com.au