

SM300

Electro-Hydraulic Scissor Hoist – 3 Tonne Capacity



The Molnar SM300 is a 3 tonne full-rise scissor hoist that is surface mounted for a low profile of only 105 millimetres. The low profile platforms are ideal for lifting a large range of vehicles including low skirted sport cars. The hoist can also be recessed into the ground.

Perfect for servicing cars, the sturdy scissor design is ideal for workshops with limited space. The hoist allows optimum access to all sides of the vehicle making it a versatile option for car body and tyre workshops.

Features

Scissor and Platforms

- › Sturdy scissor construction with no mechanical connection between sections
- › Optimum vehicle access
- › Low minimum height
- › Power Pack with integrated control unit and alarm signal
- › Double master / slave system
- › Electronic synchronisation
- › Emergency lowering valve
- › Easy adjustment of upper limit switch, for low workshops

Features

- › 4 x 40 mm rubber blocks included
- › Expansion bolts (mounting bolts) set

Options

- › Galvanised base frame for inground installations
- › Custom colours

Accessories

- › Rubber block set (40 x 100 mm)

Service and Support

- › 3 year warranty
- › Available spare parts; shipped within 24 working hours



Application



Repair and maintenance



Check-in



UNIQUE FEATURES

| | | |
|--------------------------|----------------------------|------------------|
| Technical Data | Lifting capacity | 3,000 kg |
| | Lifting height | 1,950 mm |
| | Lifting / lowering time | 45 seconds |
| | Motor | 2.2 kW |
| | Voltage | 400 V 50 Hz |
| Scissor Platforms | Platform length | 1,490 – 2,040 mm |
| | Platform width | 670 mm |
| | Distance between platforms | 720 mm |
| | Min. height | 105 mm |



**OPTIONAL INGROUND
INSTALLATION**



**GALVANISED BASE FRAME
FOR INGROUND OPTION**



SELF-LUBRICATING BEARING



OPTIONAL RUBBER BLOCKS

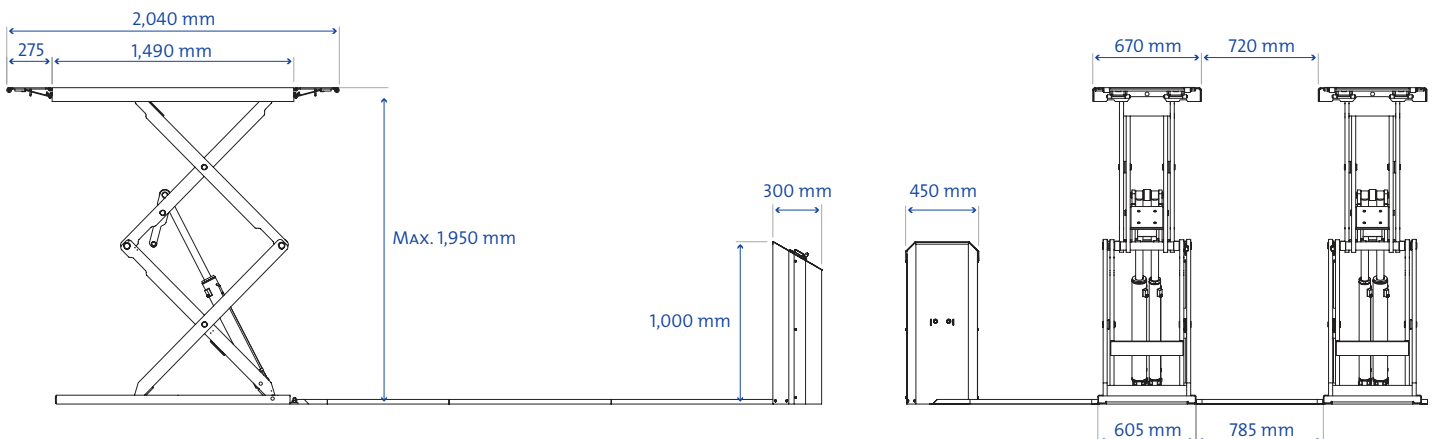

Illustrations are indicative and may be modified without notice

**Lifting
the Level**

For more information,
please contact Molnar or your
local Molnar Representative

www.molnarhoists.com.au

☎ 1300 MOLNAR (1300 665 627)
☎ 08 8234 3611 🏠 08 8234 4322
✉ sales@molnarhoists.com.au

🌐 www.molnarhoists.com.au MolnarAustralia

SM300

Electro-Hydraulic Scissor Lift – 3 Tonne Capacity

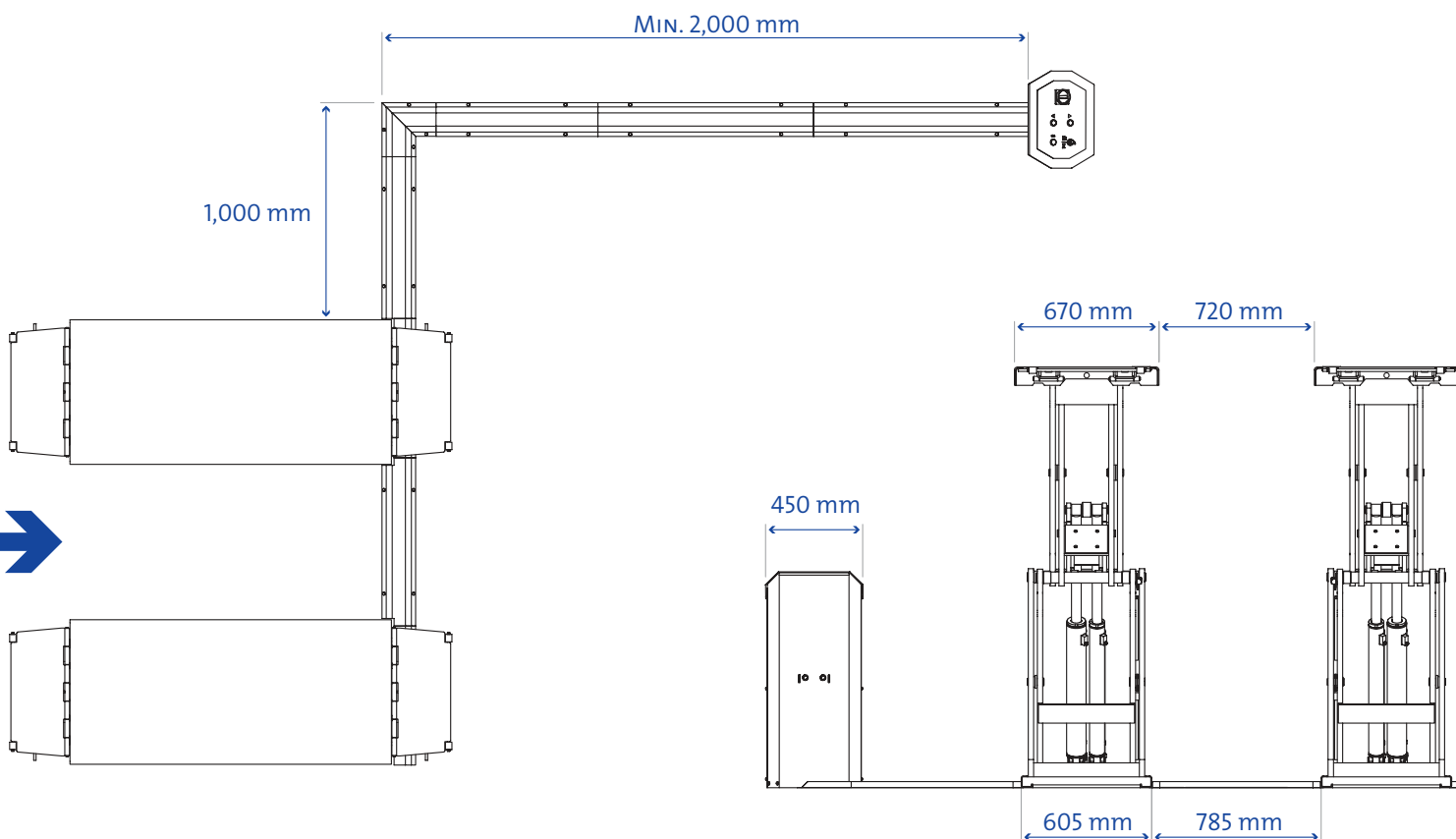
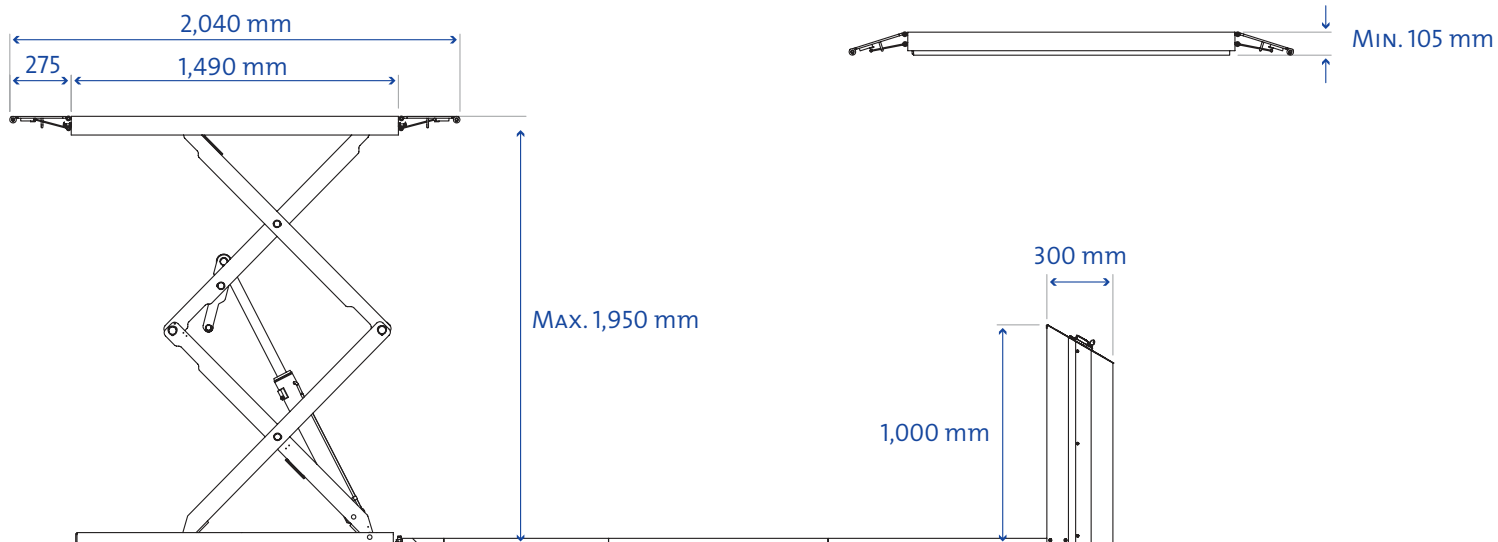

Lifting
the
Level

For more information,
please contact Molnar or your
local Molnar Representative

www.molnarhoists.com.au

☎ 1300 MOLNAR (1300 665 627)
☎ 08 8234 3611 📠 08 8234 4322
✉ sales@molnarhoists.com.au

🌐 📱 MolnarAustralia