

Installation for Molnar  
Two Post Hoist (3 Tonne)

MF1705-93-OH-3T

# ALL ROUNDER INSTALLATION

# M O L N A R



HOISTS

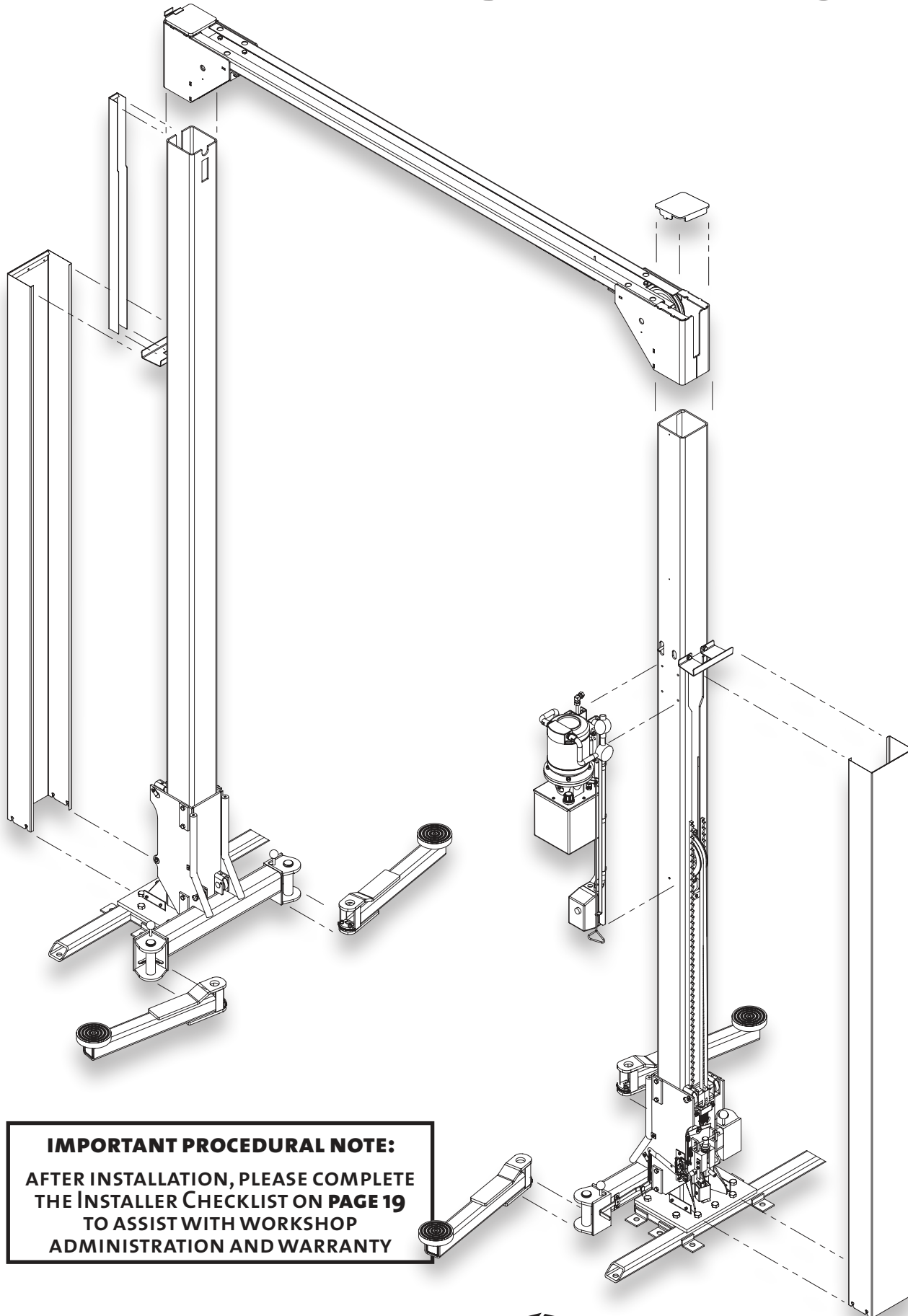

**IMPORTANT PROCEDURAL NOTE:**  
AFTER INSTALLATION, PLEASE COMPLETE  
THE INSTALLER CHECKLIST ON PAGE 19  
TO ASSIST WITH WORKSHOP  
ADMINISTRATION AND WARRANTY



BASE

OH

QL

AS



4T



# CONTENTS

Parts Glossary	03
Pre Installation - Equipment	04
Pre Installation - Packing List	05
Pre Installation - Flooring Requirements	06
Installation - 2 Unpack and position	07
Installation - 3 Pre Assemble	07
Installation - 4 Raise posts	08
Installation - 5 Square & Secure	09
Installation - 6 Fit Top Brace	09
Installation - 7 Run Long Wire Rope	10
Installation - 8 Pulley Installation	10
Installation - 9 Install Motor	12
Installation - 10 Power Hoist	13
Installation - 11 Install Arms & Auto Arm Locks	13
Installation - 12 Final Adjustment	15
Installation - 13 Lubricate, Test & Install Covers	16
Electrician Notes	18
Hydraulics Notes	18
Installer Checklist	19

## KEY

-  General warning
-  Electrical hazard
-  Installation tip

## TERMINOLOGY

From time-to-time product or process descriptions can change or evolve, for the purposes of clarity:

cables = wire ropes

pulleys = sheaves

shafts = pulley pins

safety = lock

lift pads = pick-up pads

release lever = lowering handle

This is owner manual 2 of 4



*As the policy of Molnar Hoists is one of continuous improvement, the manufacturer reserves the right to change specifications without notice. Information is correct and true at time of printing (JULY 2012)*



# PARTS GLOSSARY & LOCATION

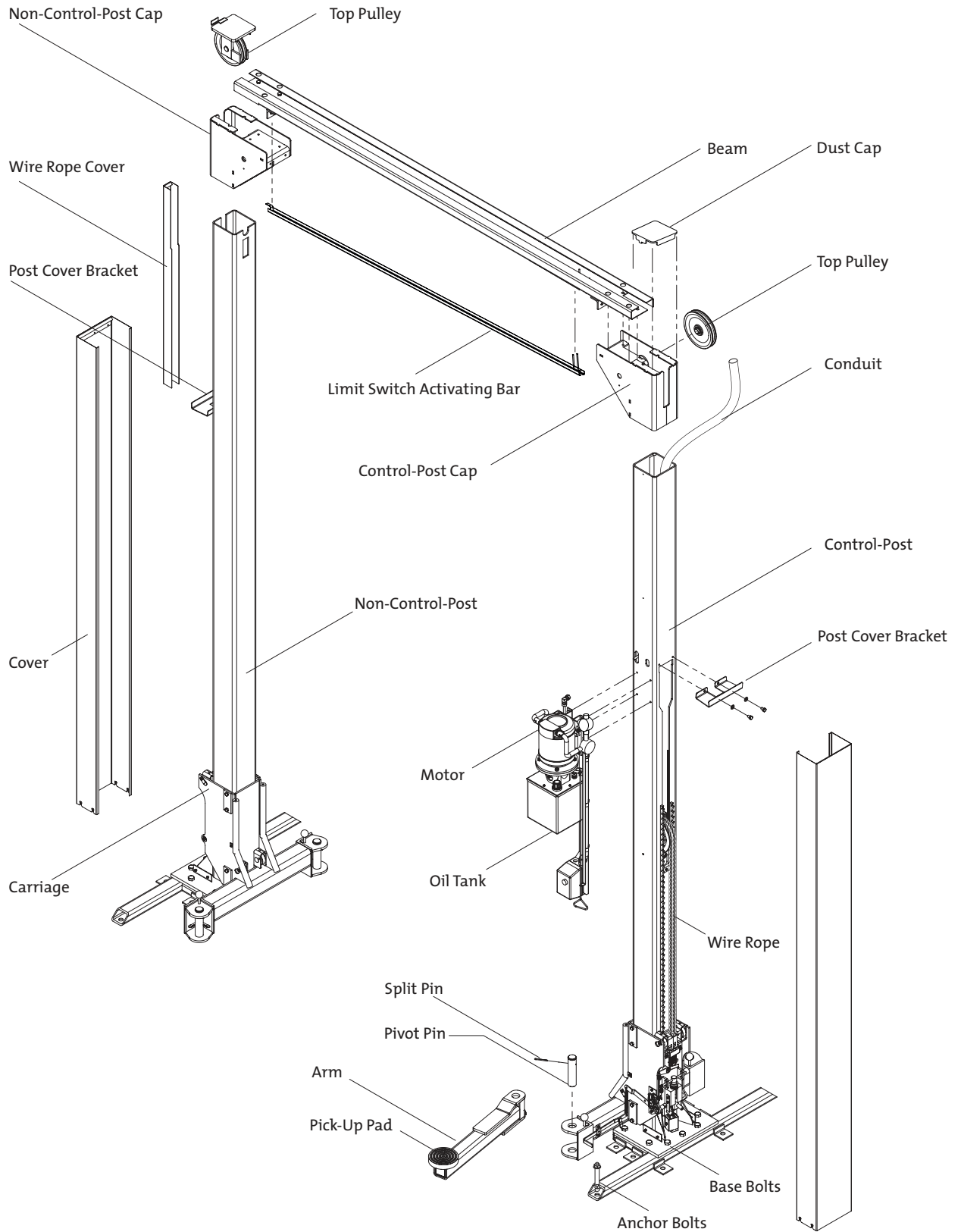



# PRE INSTALLATION - EQUIPMENT

## PERSONAL PROTECTIVE EQUIPMENT

- Gloves
- Ear & eye protection
- Steel capped boots



- Safety cones, warning signs and tape



## ELECTRICIAN

A licensed electrician must perform all electrical work including power connection and wiring (see Section 10 Power the Hoist)



## POWER REQUIREMENTS

3 Phase, 3 HorsePower, 415 Volt. Requires 3 Phase and Earth, 5 Amp.

*OR 240 Volts under load at motor, hard wired on 20 Amp circuit (if installing an optional Single Phase motor)*

## LUBRICANT

- Grease
- Dry lubricant
- General lubricant
- Wire Rope lube
- Hydraulic oil

## RECOMMENDED

- > Marine grade wheel bearing grease eg. molybdenum grease
- > CRC dry glide
- > Wurth HHS dry lube
- > CRC Tac-2
- > Wurth HHS Lube
- > Lanotec heavy duty liquid lanolin
- > 85-90 gear oil
- > 5 litres AWH46 (supplied with hoist)

## MATERIALS

- 16 sleeve anchors (bolts): 20mm diameter by a minimum 100mm in length with an M16 thread.

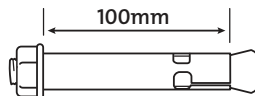

**NOTE** depending on the floor condition and the amount of shimming, longer anchors may be required.

**NOTE** "100mm" refers to the length of the sheaf (not the overall length of the bolt)

**NOTE** Some authorities do not approve expanding type anchorage devices.

- An assortment of shimming in various thicknesses.

**NOTE** shimming should be minimum size of 50mm square and either zinc steel or construction grade plastic.

## TOOLS











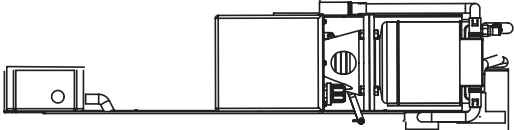
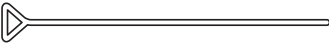









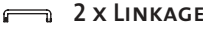

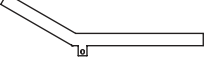
- 2.4 metre platform-style step ladder or an appropriate elevated work platform
- Crane or appropriate lifting device
- Pallet jack or appropriate material handling device
- 1200mm spirit level
- Pry bar - heavy and light duty
- Hammer drill with a 20 mm masonry drill bit
- Air Impact Gun with 24 mm socket
- Tin snips
- Pull cable (1.2 m, capable of pulling electrical cable through conduit)
- 2 tape measures
- Chalk line
- Oil funnel with an end to fit into a 1/4 bsp hole
- Standard tool kit
  - 2 screwdrivers
  - Phillips Head screwdriver
  - Spark plug socket - 5/8" or 16mm
  - Allan Key, 6mm and 3mm
  - Clamp wrench (AKA vice grip)
  - Cutting pliers (AKA wire cutters)
  - Rubber mallet
  - Hammer
  - Adjustable wrench
  - Spanner (16mm, 10mm and 13/16th imp)
  - Shifting spanner - 450mm
  - Socket set
  - Needlenose pliers
  - External circlip pliers
  - Box cutter
  - Black Texta

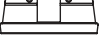
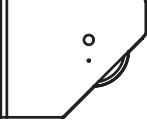

# PRE INSTALLATION - PACKING LIST

Check all items are available prior to assembly.

## SMALL TIMBER CRATE CONTENTS

-  **MOTOR UNIT**
-  **LOWERING HANDLE**
-  **4 X FLAT M10 WASHER**
-  **2 X SPEED CLIPS**
-  **2 X FLAT M5 WASHER**
-  **ROLL PIN**
-  **20 X 12MM M10 BOLT**
-  **SPRING**
-  **4 X 10MM M6 BOLT**
-  **SLEEVE**
-  **2 X 12MM M2.5 BOLT**
-  **BRACKET**
-  **2 X LINKAGE TOGGLES**
-  **3 X SPLIT PIN**
-  **4 X DOOR PROTECTORS**
-  **CONTROL POST DUST COVER**
-  **2 X POST COVER BRACKET**
-  **CONTROL POST END CAP**
-  **NON-CONTROL POST END CAP**
-  **NON-CONTROL POST TOP PULLEY**
-  **CONTROL POST BOTTOM PULLEY**
-  **5L OIL**
-  **4 X PIVOT PIN**
-  **4 X ARMS**
-  **AUTO ARM LOCK KIT**  
(FOR CONTENTS: SEE PAGE 14)

## LARGE TIMBER CRATE CONTENTS

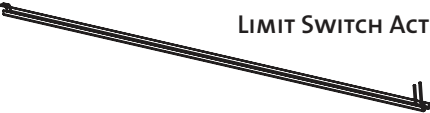
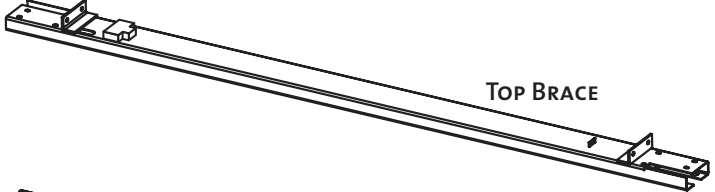
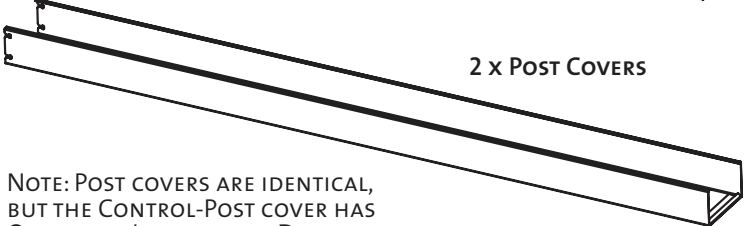
-  **WIRE ROPE COVER**
  -  **LIMIT SWITCH ACTIVATION BAR**
  -  **TOP BRACE**
  -  **2 X POST COVERS**
- NOTE: POST COVERS ARE IDENTICAL, BUT THE CONTROL-POST COVER HAS OPERATION INSTRUCTION DECAL

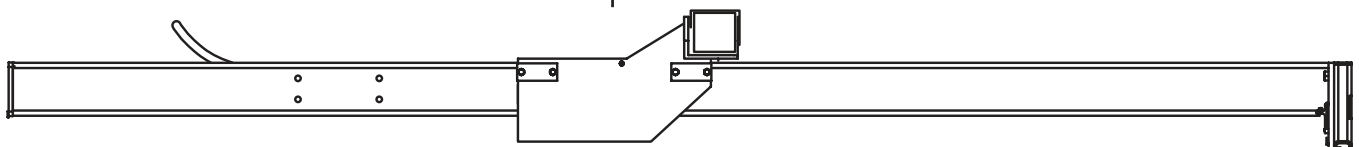

CONTROL POST, WITH CARRIAGE (IDENTIFIED BY THE CONDUIT)

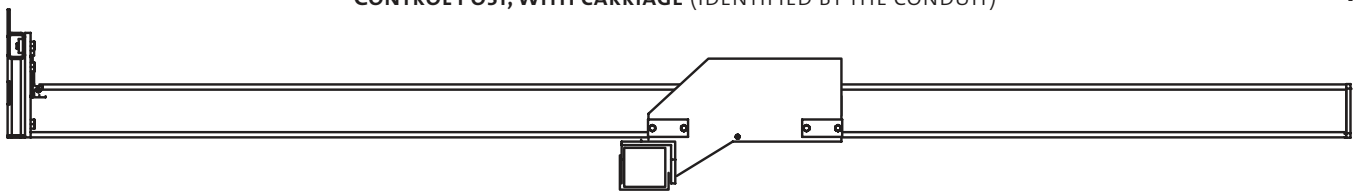

NON-CONTROL POST, WITH CARRIAGE



# PRE INSTALLATION - FLOORING REQUIREMENTS

## SLAB / FLOOR

It is the owners responsibility to provide a satisfactory site area.

- The floor should be a single reinforced concrete slab.
  - Minimum concrete thickness = 100mm
  - Prepared base 100mm thickness of quarry rubble compacted to 95%
  - 25 Mpa concrete

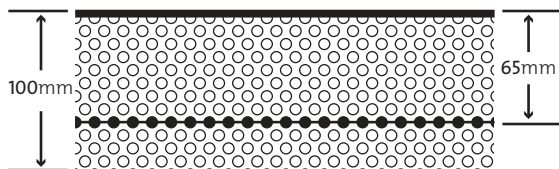

- SL81 reinforcement mesh
- Minimum thickness of concrete above mesh = 65mm
- Minimum plan dimensions of 4600mm x 1800mm

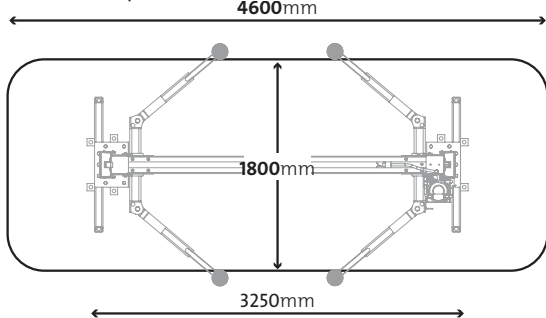

- The floor must be flat and level. A level tolerance between posts of 10mm is allowable. Check with straight edge and spirit level.



- The reinforcement should be selected and located to accommodate a bending moment of 10.72 E6 Nmm at the end of the steel footing attached to each post. The concrete footing must comply with AS3600-1994 concrete structures.
- If there is any doubt about the quality of the floor, a replacement slab should be installed. Use a qualified person to design the replacement slab.

No liability for any damages will be accepted should the hoist be installed on an unsuitable floor

## 1 SITE / POSITION

Cordon off work area using safety cones or other safety barricade. Ensure area is clear of any obstruction prior to installation

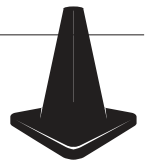

Overhead clearance of 4000mm

Site should have a 600mm walk way around the hoist and vehicle. If clearances are not available consult Molnar Hoists for advice.

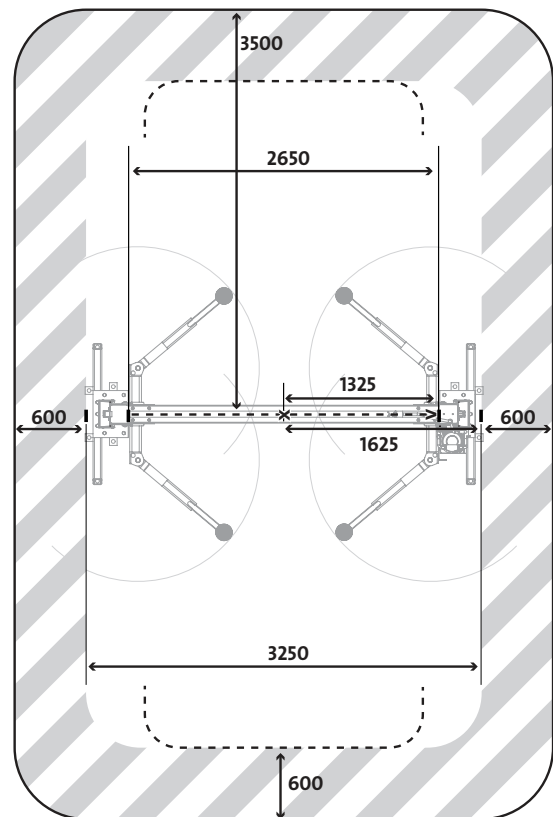

- Measure and mark required clearances around the site – minimum 3500mm in front of hoist and 600mm side clearance.
- Measure overall hoist width (3250mm) and mark external edges.
- Use a chalk line to mark the centre line of the posts and mark the centre point (1625mm).
- Measure 1325mm off each side of the centre point and mark internal edges using a 'V' symbol, to ensure the marking is visible when positioning and sliding post into place.



# INSTALLATION

## 2 UNPACK AND POSITION

- 1 Using a pallet jack, position hoist in front of the marked line.
- 2 Cut bindings and remove the plastic cover. Cut the steel strapping around the two timber crates. Open crate lids with pry bar and lay out contents on the floor, clear of the working area. Discard crates and packing material.

**Plastic cover can be used to collect packaging refuse**

- 3 Carefully check contents against the packing list on the previous page. If any contents are missing, stop installation and immediately contact your distributor.
- 4 Remove strapping holding the lifting arms to the hoist. Discard strapping and set lifting arms aside.
- 5 Locate the control-post (identified by the conduit). Position hoist so that the base of the control-post is positioned on the preferred side for motor operation.

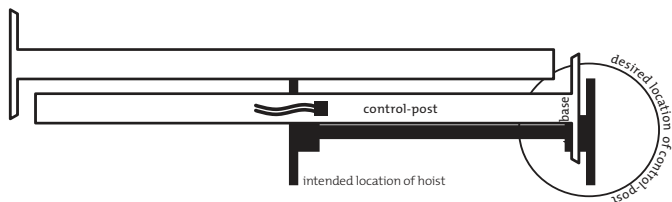

- 6 Once correctly positioned, lower the pallet jack until the packing legs are touching the ground but the post are still supported by the pallet jack.
- 7 First cut away the strapping from around the carriage and then cut away the remaining strapping from around the hoist.

**Do not cut strapping on the control post marked with red and white sticker, this strapping must remain until posts are upright.**

- 8 Lower hoist and carefully remove pallet jack
- 9 Using the pallet jack or pry bar, carefully separate the posts to create about a 200mm gap between them.

## 3 PRE ASSEMBLE

- 1 Working first on the non-control post, use the pallet jack to lift it up to remove the load on the packing leg. Using an Air Wrench, undo the 2xM16 bolts and nuts holding the packing leg to the base frame. Remove the packing leg and refit the M16 nuts and bolts to it ready for return.
- 2 Repeat this process for the control post

**Packing legs must be returned to distributor or place of purchase for full refund of deposit**

- 3 Working on the control-post, place the pallet jack under the top end, raise slightly and swing the top clear of the other post.
- 4 Pull the conduit through the top of the control-post, twisting as you pull, until approximately 150mm is left protruding from the side of the post.

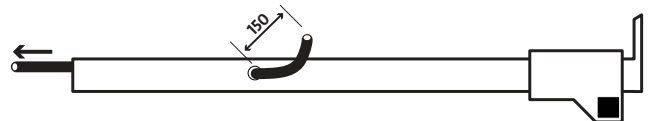

- 5 **Locate the control-post cap:** **a.** unscrew the M6 bolt holding the pulley in the control-post cap. **b.** Support the pulley while removing the pin. **c.** Remove the pulley and set to one side, ensuring both pulley spacers have also been removed.

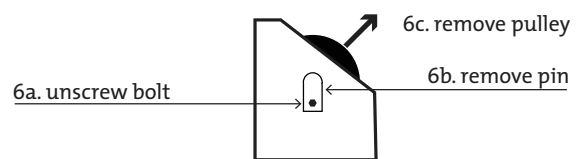

- 6 **Fit control-post cap to control-post:** feed the conduit through the top of the control-post cap while sliding the cap onto the control-post. Tuck the conduit into the pulley hole to secure during installation.

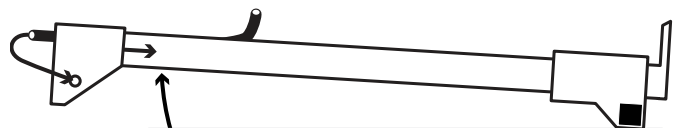

- 7 Lower to ground and remove the pallet jack.



## INSTALLATION

- 9** Working on the non-control-post, place the pallet jack under the top end, raise slightly and swing the top clear of the other post. Raise post approximately 500mm before sliding on the non-control-post cap.



- 10** Lower to ground and remove the pallet jack.
- 11** Using an air impact gun, remove the M16 bolt holding the packing timber to the base of each post, discard the timber and refit the bolt.

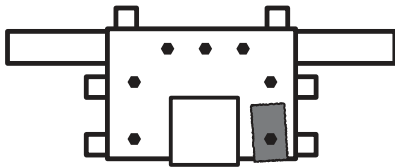

- 12** Check all base bolts are tight.
- 13** Fit 4 x M10 bolts halfway into the side of the control-post. Slide the motor onto these bolts and tighten (motor mounting holes are elongated to aid fitting).

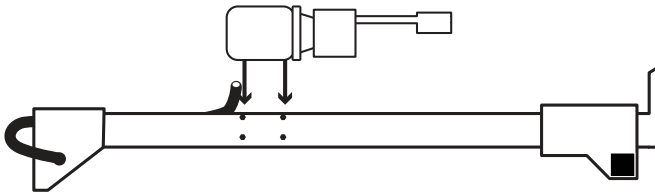

### 4 RAISE POSTS

- 1** Using the pallet jack, position the control-post over the centre chalk line with base in the approximate position.
- 2 Use a lifting device (such as crane) to raise the post.** Place a sling or other strapping around post (above the twin pulley, ensuring the sling position is above the centre of gravity) and raise the top of the post up 300mm. Slide the post down through the carriage until the locking toggles click at least three times.

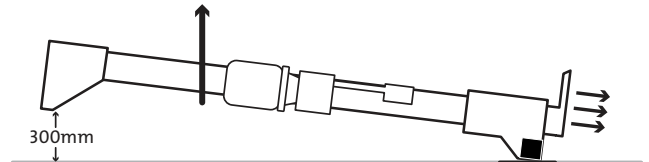

- 3** Continue to raise the post until it is vertical, then carefully manoeuvre until in-line with centre and distance markings, and lower. Check the stability of the post before removing sling and lifting device. In the event of an uneven floor surface, a shim may be required under the corner of the base to stabilise the post.
- 4** Repeat process for the other post.
- 5** Remove the top strapping and block (with red and white sticker) from around the control-post.
- 6** Using a spirit level, check each post is vertical on both plains. Adjust by shimming between the base frame and floor as needed. Refer to the diagram below for correct shim points.

TO LEVEL AND STABILISE POSTS, SHIM AT THE POINTS MARKED WITH AN X, UNTIL GAPS ARE FILLED.

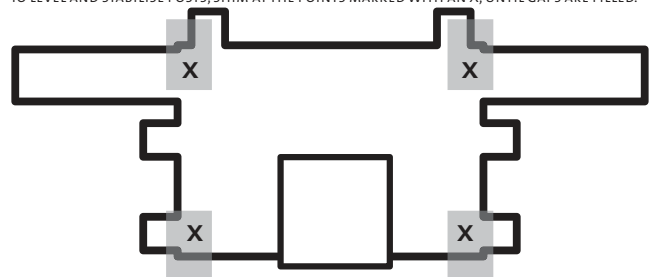



# INSTALLATION

## 5 SQUARE AND SECURE

- 1 Check distance between posts is correct (exactly 2650 mm) and adjust as needed.
- 2 Check both posts are parallel and square to each other. Using two tape measures, measure between each side of the base frame and adjust until even.

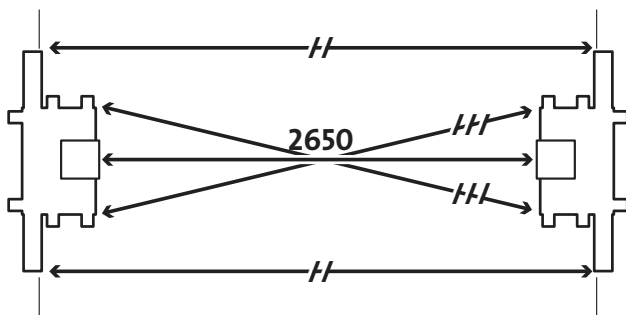

- 3 Recheck the distance between the posts to ensure they have not moved during any adjustments.
- 4 Mark the centre point to drill. Using a hammer drill, drill and bolt the two side bolt positions on each post using 20mm sleeve anchors to secure the posts.

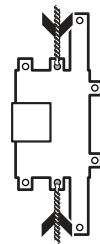
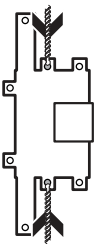

 To minimise concrete dust contaminating Wire Ropes prior to installation, do not install all anchor bolts at this time

## 6 FIT TOP BRACE

- 1 To install the top brace, position a platform ladder between the posts to allow a solid work space in front of you (check your position is not too tight or too far reaching).

- 2 Use a crane to raise the top brace above the posts, ensuring the end with the limit switch is positioned towards the control-post.

The top brace sits in the recess in the top of the post caps.

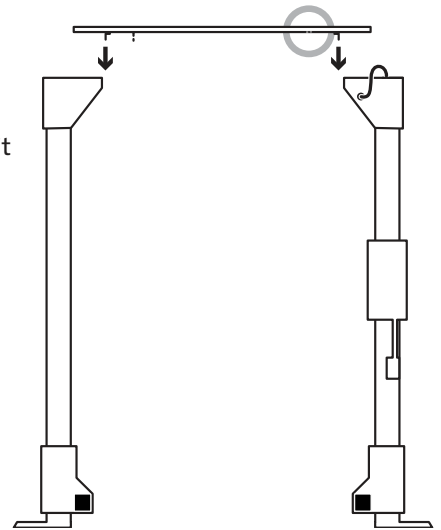

- 3 Reposition the ladder to the non-control-post side and using a spark plug socket (5/8 or 16mm) for reach, secure the top brace using 6 x M10 bolts. Start all 6 bolts before tightening.

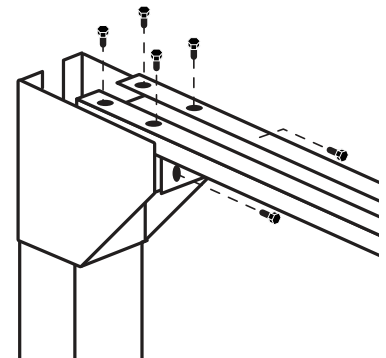

- 4 Repeat the process at the control-post side.



## INSTALLATION

### 7 RUN LONG WIRE ROPE

- 1 Pull long Wire Rope up and out of post through the top of the post. Remove the cable nut from the end. Ensure the Wire Rope is not knotted, twisted or wrapped around the oil pipe inside the post.

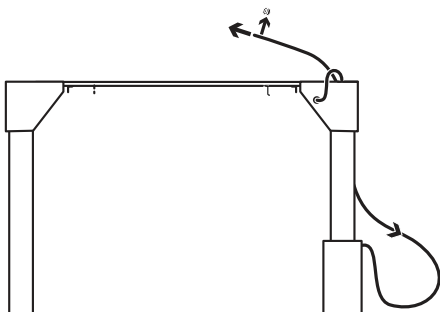

- 2 Allow Wire Rope to slide down the inside of the post and out through the pulley cut-out on the side of the post, until the threaded Wire Rope terminal end can be fed through the pulley hole between the Top Brace and the Post Cap.
- 3 Feed the Wire Rope across the top brace and through the centre cut out on the non-control-post and feed down the back of the non-control-post.

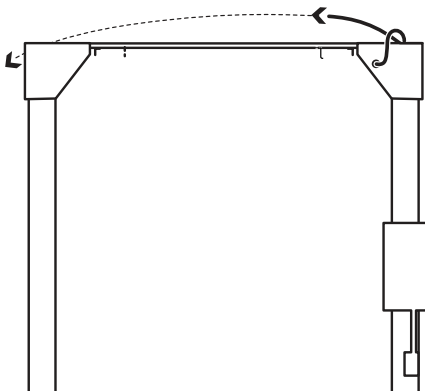

### 8 PULLEY INSTALLATION

Before fitting pulleys, check the cylinder spigot is securely located down into the support plate hole; this is viewed through the square cut out towards the bottom on the back of the control-post.

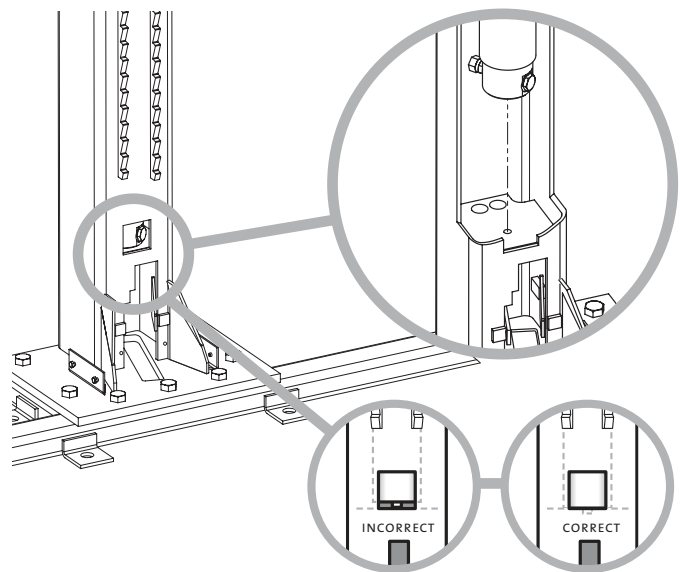

If the cylinder is not correctly in the location hole, use a flat screwdriver to slide the base of the cylinder until it sits correctly.

 It is critical to the operation of the hoist that the cylinder is correctly positioned.

#### CONTROL-POST BOTTOM PULLEY

- 1 With the control-post carriage on the locks, pull approximately 500mm of Wire Rope length from the bottom pulley slot on the outside of the post.
- 2 From this position, remove the bottom 2 x M6 bolts from the outside of the post.

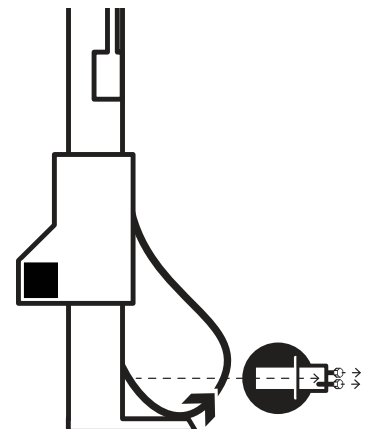



## INSTALLATION

- 3** On the pulley, remove 2 x M6 bolts from the cable retaining bracket to remove.

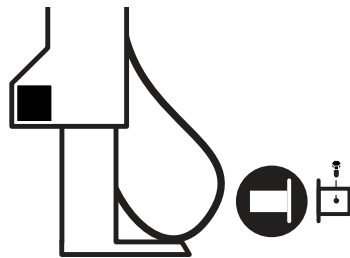

- 4** Remove the pulley pin and re-grease the bush before refitting.

- 5** Fit the pulley into the loop of Wire Rope, ensuring the Wire Rope is positioned in the pulley groove.

- 6** Insert the pulley assembly into the post, ensuring the side brackets locate into the mounting blocks inside the post.

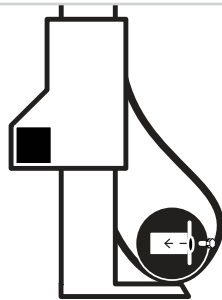

- 7** Fit 2 x M6 bolts through each side of the bracket and secure to the mounting post. Do not over tighten.

- 8** Reaching inside the post above the twin pulley, pull excess long Wire Rope up to secure the Wire Rope into the bottom pulley groove.

- 9** Recheck the Wire Rope is located in the pulley correctly and refit the cable retaining bracket. Then retighten side bolts ensuring the bracket sits firmly against the stop.

- 10** Check the pulley rotates freely.

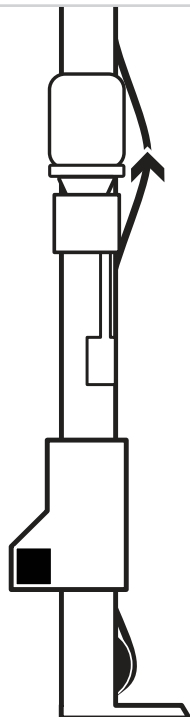

### CONTROL-POST TOP PULLEY

- 1 Locate the top pulley (removed at step 3.5)
- 2 Using a small amount of grease for hold, position the pulley spacers on each side of the pulley. Re-grease the pulley bush.
- 3 Reinsert the top pulley into the smaller of the two openings underneath the control-post cap, being careful not to dislodge the spacers on either side.
- 4 Align pulley and pin hole before fitting the pulley pin and bolting to secure.
- 5 Ensure the Wire Rope is laying correctly in the pulley groove.

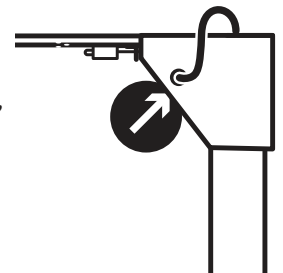

### NON-CONTROL-POST TOP PULLEY

- 1 At the top of the non-control-post, place top pulley. Unscrew the bolt and remove the pulley pin to remove the pulley and spacers.
- 2 Feed the Wire Rope through the pulley assembly. Re-grease the pulley bush and re-grease spacers to re-attach.
- 3 Slide the pulley back down until the pulley lines up with the pin hole, ensuring the spacers do not dislodge before refitting the pulley pin and securing the bolt. Check the pulley spins freely.
- 4 Flip and insert the pulley assembly into the top of the post, with the bracket hook pointing outwards.

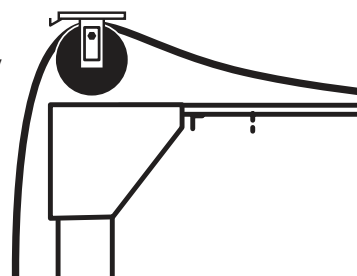
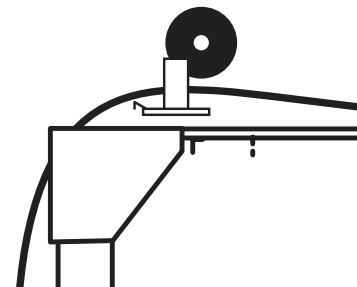
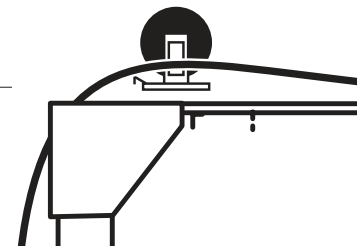



## INSTALLATION

- 5** Feed the threaded Wire Rope end through bracket on carriage until at least 100mm of the end protrudes.

Note, the carriage may need to be raised to insert the Wire Rope end.

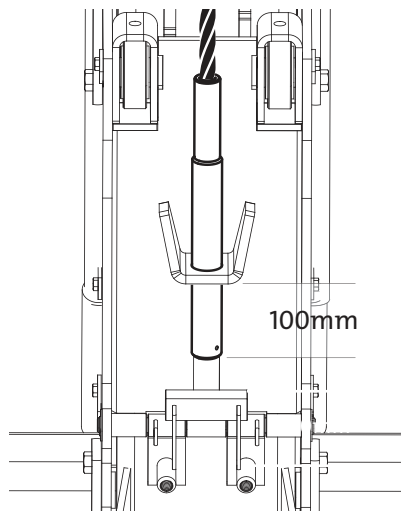

- 6** Insert spring and sleeve over cable end. Insert the bracket (with bracket arms positioned against the carriage) and secure cable end with the cable nut.

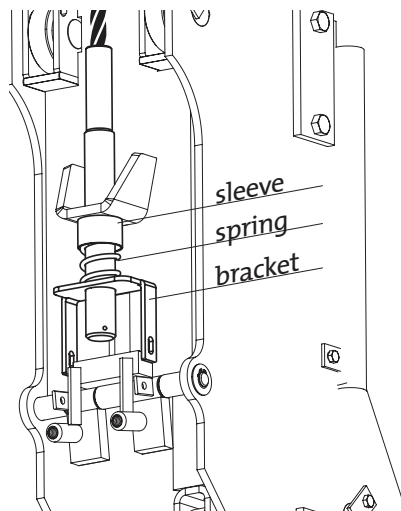

- 7** Tighten the cable nut up approximately 30mm to fully expose the cable retaining pin hole.
- 8** Feed linkages through the inside of the bracket, with washer at top, and attach to linkage holes. Insert split pins to secure linkages.
- 9** Fit roll pin through hole in the Wire Rope end and hammer in, leaving a few millimetres of the pin protruding.

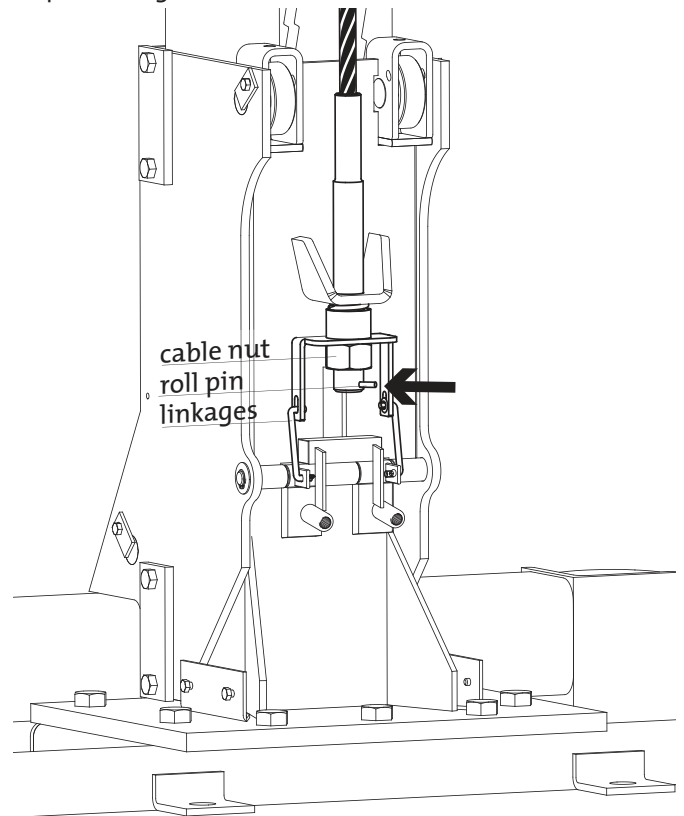



## INSTALLATION

### 9 INSTALL MOTOR

- 1 Remove and discard two oil pipe plugs (from motor and post).
- 2 Connect the oil fittings between tank and post, and tighten fitting on top of the tank.
- 3 Check and tighten motor mounting bolts.
- 4 Unroll all three wires wrapped around top of the motor.  
From the top of the control-post, feed the pull cable down the conduit and attach to the three wires, then pull the wires through the conduit and out the top of the post.

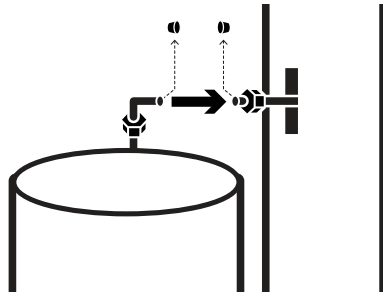

- 5 Feed the electrical conduit into the top brace, under the brace lip.

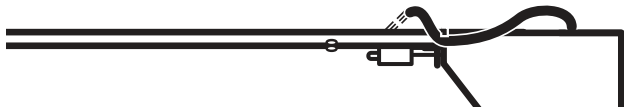

- 6 Connect each coloured wire to the corresponding wire in the limit switch, using the bullet terminals fitted to the ends.
- 7 Attach the conduit to limit switch bracket to secure and contain coloured wires.
- 8 Remove one screw from the top junction box and swing to open. Pull any excess wire into this box until the wiring between the motor and the limit switch is tight.
- 9 Recheck oil fittings are tight.
- 10 Fit the lowering handle through the guide bracket located next to Control Button and push up to attach to the LOWERING handle located on the oil tank. Secure with split pin and check the handle is operational (ensuring the LOWERING handle pivots freely and returns when the handle is released).
- 11 Remove the oil tank cap, insert funnel into the hole and fill with five litres of recommended hydraulic oil. Replace the tank cap once finished.
- 12 Fit the post cover brackets to the outside of each post, ensuring the bracket lip faces upwards. On the non-control-post, make sure the Wire Rope runs through the bracket cut out. Secure these brackets using the M10 bolts and washers (two of each per side).

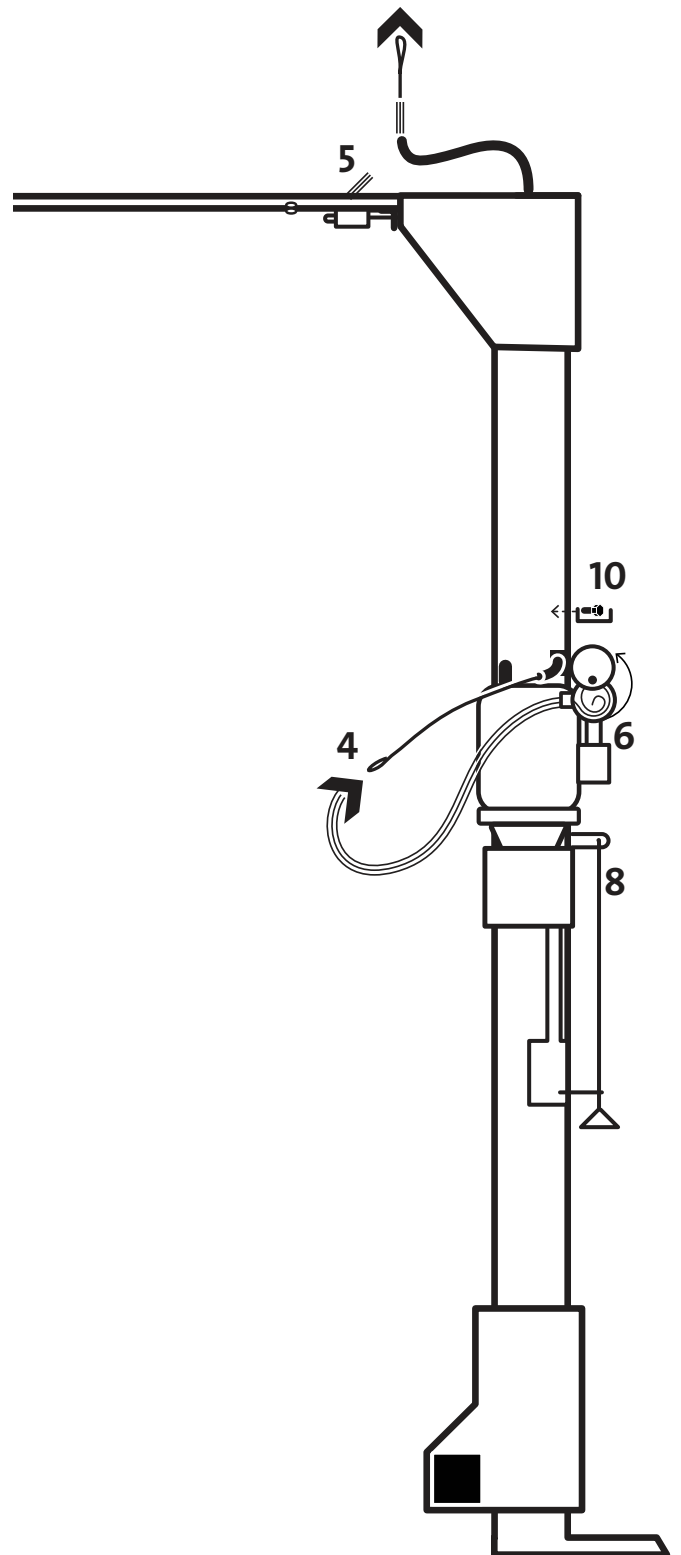



# INSTALLATION

## 10 POWER HOIST



A licensed electrician must perform all electrical work



Do not mount or secure power supply to Hoist covers, as it will impede Hoist servicing

- 1 Use a licensed electrician to connect the power supply to the hoist, using the lower junction box located on the starter button bracket.
- 2 Once connected, press the CONTROL button to raise the hoist (the twin pulley begins to raise and take up slack in the twin Wire Ropes on the control-post). If the twin pulley does not move within 10 seconds, have the electrician reverse the wiring to change the rotation of the motor.
- 3 Raise the hoist to waist height.  
**NOTE:** Do not attempt to disengage the manual LOCK lever.
- 4 Fit the limit switch activating bar to the top brace: on the non-control-post side, insert the bar tab into the slot.

On the control-post side, slide the two prongs into the corresponding holes on the top brace and secure with speed clips.

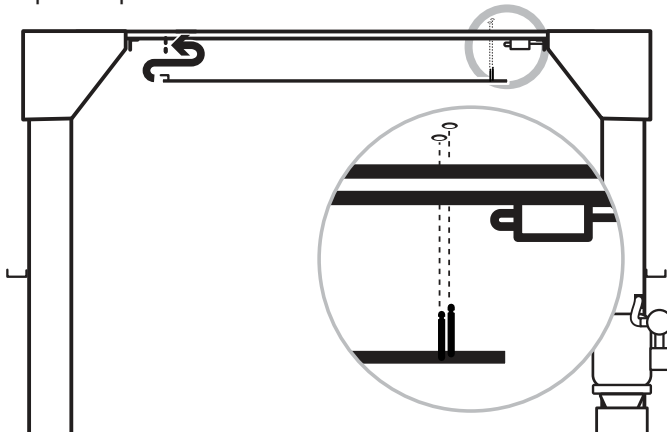

- 5 Test operation of the two limit switches.

## 11 INSTALL ARMS & AUTO ARM LOCKS



To ensure correct functionality of the auto arm locks, the Auto Arm Lock shaft must be positioned over a smooth, even surface (free from cavities or joints). If not possible, striker plates must be installed.

- 1 Unpack Auto Arm Lock pack and lay out contents in a clear working space. Check content against packing list provided.

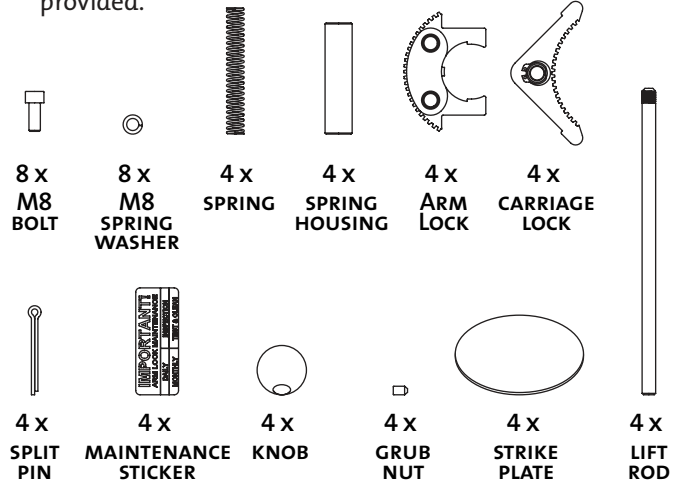

- 2 Layout all four arms ready for pre-assembly.
- 3 Using 2 x M8 bolts and 2 x M8 spring washers, secure the Arm Lock inside the lifting arm. Hand tighten to firm.

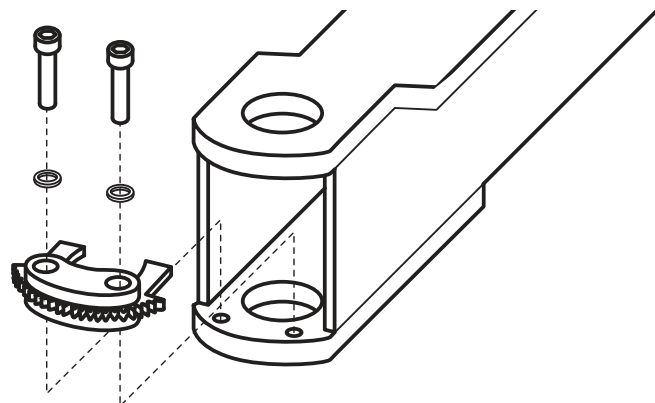

- 4 Repeat process for all four arms.
- 5 Raise the carriage to working height.



## INSTALLATION

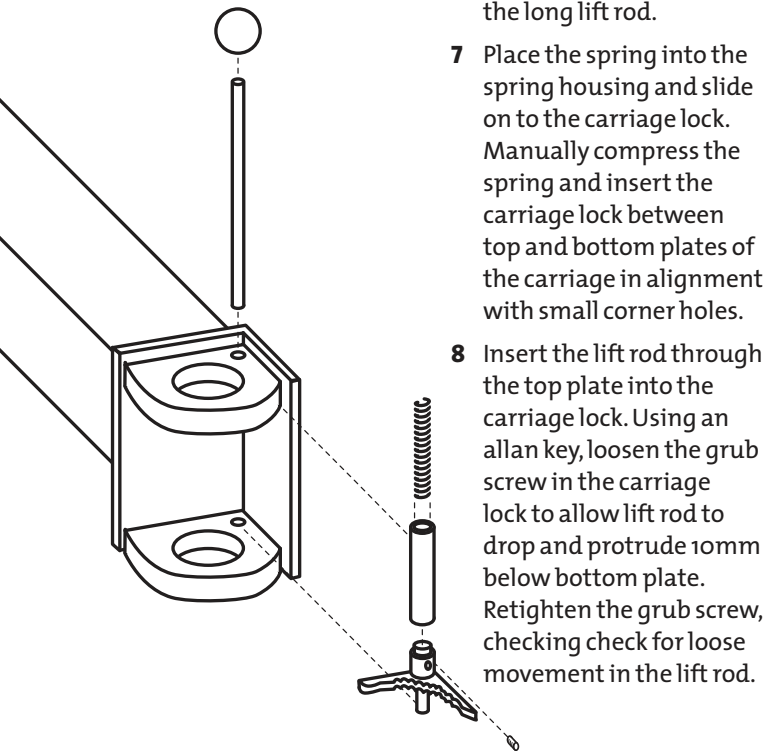

- 6 Attach the black knob to the long lift rod.
- 7 Place the spring into the spring housing and slide on to the carriage lock. Manually compress the spring and insert the carriage lock between top and bottom plates of the carriage in alignment with small corner holes.
- 8 Insert the lift rod through the top plate into the carriage lock. Using an allen key, loosen the grub screw in the carriage lock to allow lift rod to drop and protrude 10mm below bottom plate. Retighten the grub screw, checking for loose movement in the lift rod.

9 Repeat process for all four arms.

10 **Fit lift arms to the carriages** (arms can be attached at any corner). Insert arm in carriage, aligning lock teeth before inserting the pivot pin, with pinhole facing inwards. The lift rod may need to be raised to disengage lock to fully insert the pivot pin.

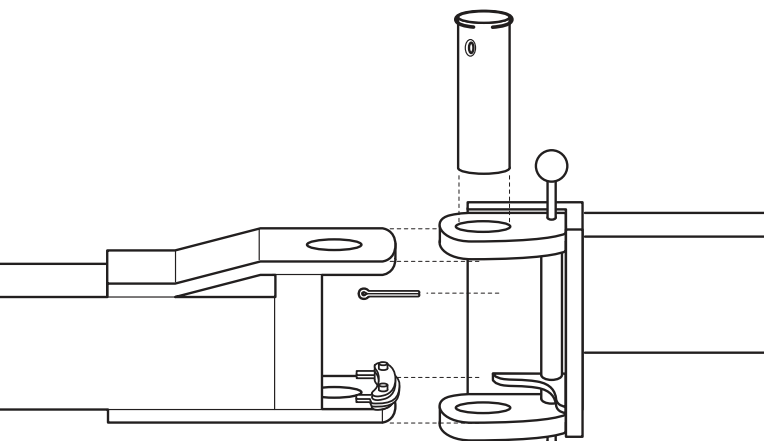

- 11 Insert split pin through pinhole to secure the pivot pin. Open the split pin using a screwdriver or other tool (the pivot pin may need to be rotated for access).
- 12 Repeat process for all four arms.
- 13 If striker plates are required (due to cavities or joints underneath the auto arm lock shaft), use double sided tape to secure in position directly beneath the base of the lift rod.

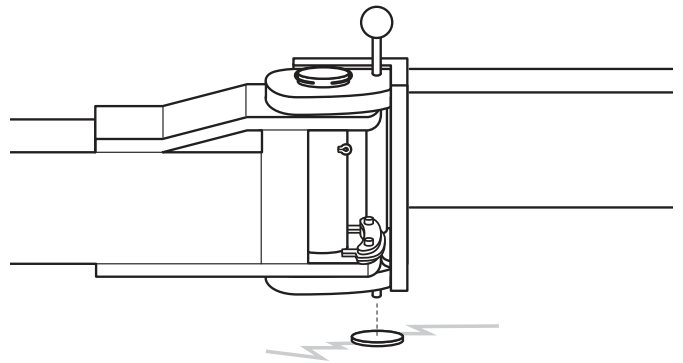

- 14 Place Arm Lock Maintenance sticker adjacent to the Auto Release Arm Lock as shown

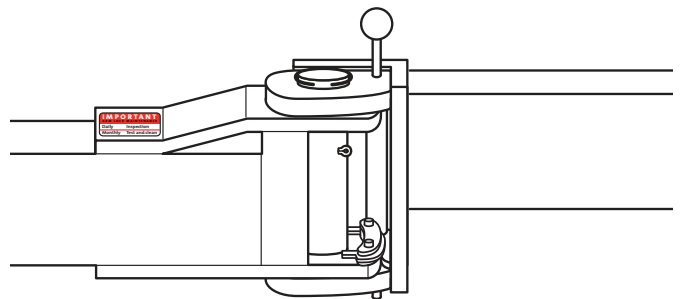

- 15 Slide arms in and out to check extension stops are in place.
- 16 Check all four pick-up pads are rotating freely. Ensure the retention washer and circlip at the base of the pick up pads is fitted correctly.



# INSTALLATION

## 12 FINAL ADJUSTMENT

- 1 Remove 1 x M6 bolt on the side of the carriage and fit door protectors over the edge. Reinsert bolt to secure. Repeat process for all four protectors.
- 2 Raise hoist mid way, unlock safety and lower the hoist to the ground. Bleed air out of hydraulic system by holding the lowering handle down for five minutes.
- 3 **Pre-stretch the long Wire Rope:** with the hoist fully lowered, measure the distance between the bottom of the non-control-post carriage and the floor – the long Wire Rope needs to be adjusted until this measurement equals 25mm (the Wire Rope will stretch under load and this ensures the vehicle sits level when raised).

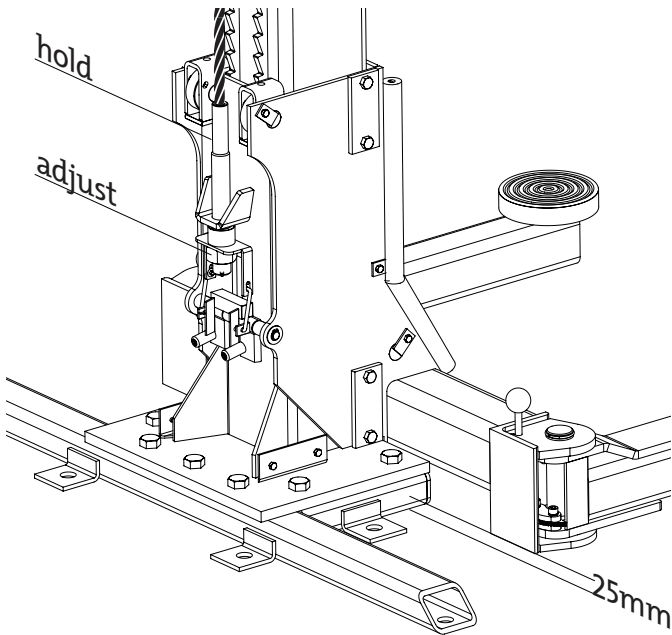
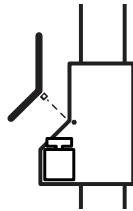

Adjust the long Wire Rope by tightening or loosening the end cable nut to increase or decrease the distance between carriage and floor until the measurement is exactly 25mm.

- 4 **Readjust auto arm lock rods to ensure correct disengagement.** Using a screwdriver, lever underneath the carriage lock to manually raise the lift rod and disengage lock mechanism. Tighten grub screw to secure Rod in the correct position.

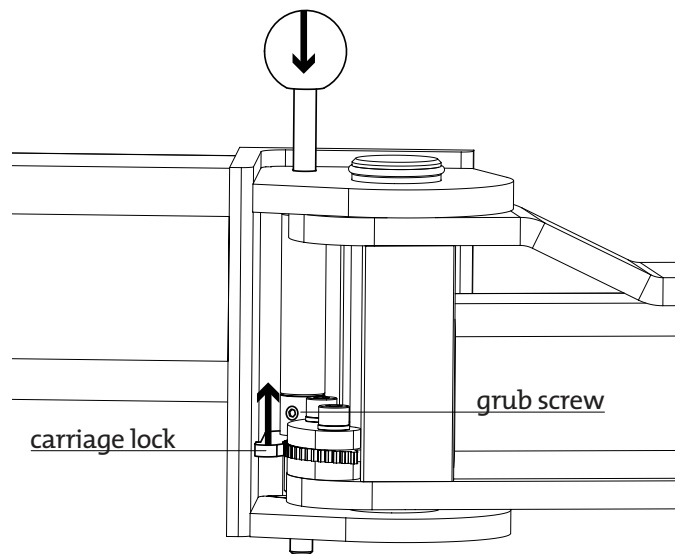

With extension arms fully extended, check engagement and disengagement through complete movement of arms.

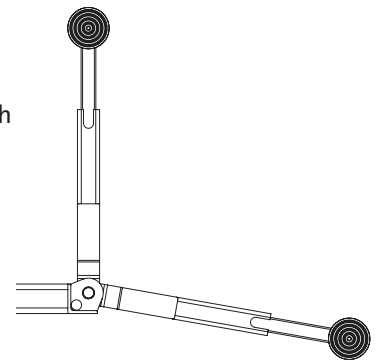

- 5 Place shimming (square galvanised washer; minimum 50mm with 20mm hole) under the 6 remaining anchor bolt holes. Drill holes and bolt with remaining anchor bolts. Repeat process for the other post.

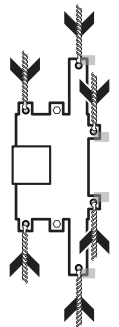
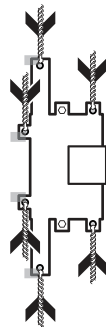



# INSTALLATION

## 13 LUBRICATE, TEST & INSTALL COVERS

- 1 Apply lubricant to  
→ inner roller tracks  
→ side wear tracks  
on both posts with Dry Spray Lubricant

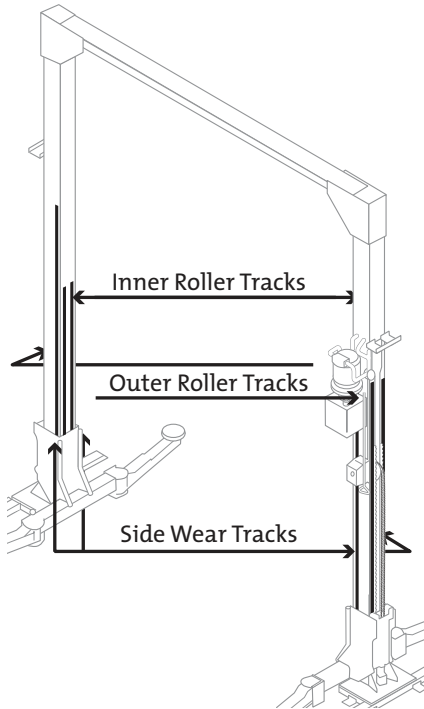

- 2 Grease Outer Roller Tracks with marine grade wheel bearing grease  
Outer roller tracks can be heavily lubricated as the outer tracks are fully covered by the Hoist covers.

- 3 Check free movement of Lowering Handle.  
Apply dry lubricant to pivot point (behind the motor).

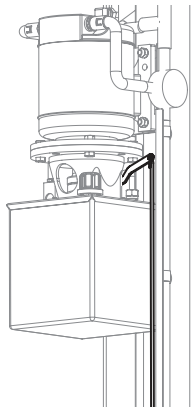

- 4 Lubricate the safety mechanism and linkages with spray lubricant. Check operation by raising and lowering.

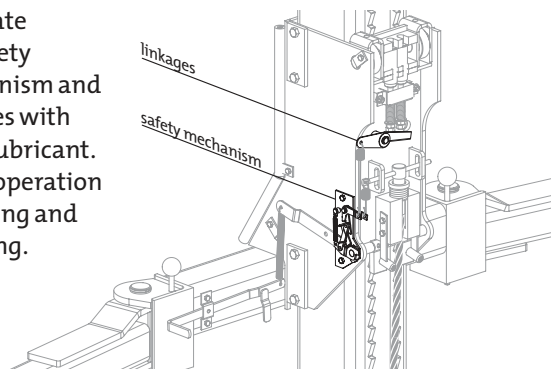

- 5 Lubricate Wire Ropes with cable lubricant, spraying at the top of the Wire Rope and allowing to run down. Follow and reapply at each stop point until full length of Wire Rope is lubricated.

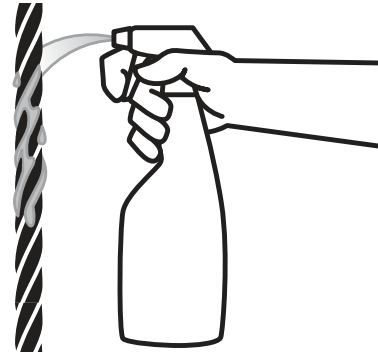

- 6 Loosen 4 x M6 bolts at the base of the control-post. **Locate control-post cover** (the cover with the operation sticker), lift cover over the top mounting bracket and slide down into position, around the four cover bolts. Retighten bolts.

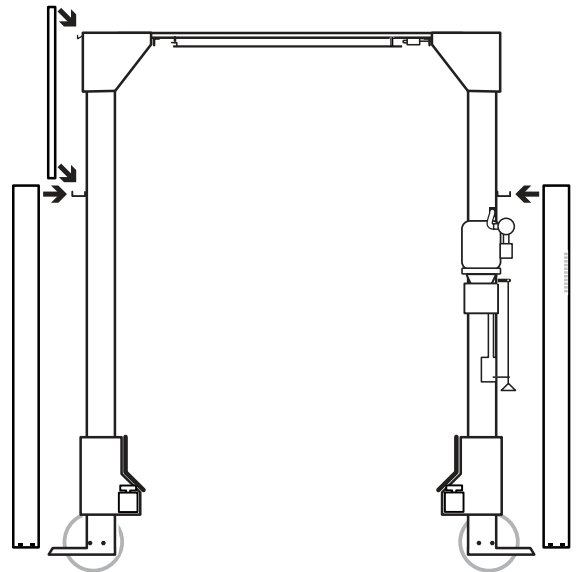

- 7 Repeat process for the non-control-post cover.

- 8 Place control-post dust cover on to the top of the control post and secure by bending tabs into holes in top cap assembly.

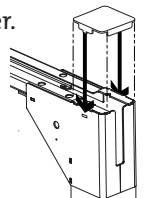

- 9 From the top of the non-control-post, fit the Wire Rope cover. Attach the cover over the hook above the top pulley and slide down until base locates in the square cut out in the cover mounting bracket.

- 10 Clean area and dispose of packaging.

- 11 Place a vehicle on hoist and run hoist through at least three cycles, checking for smooth operation and any oil leaks.

- 12 Ensure owner / operator is trained in the correct use of the hoist.



# ELECTRICIAN & HYDRAULICS NOTES

## JUNCTION BOX CONNECTION

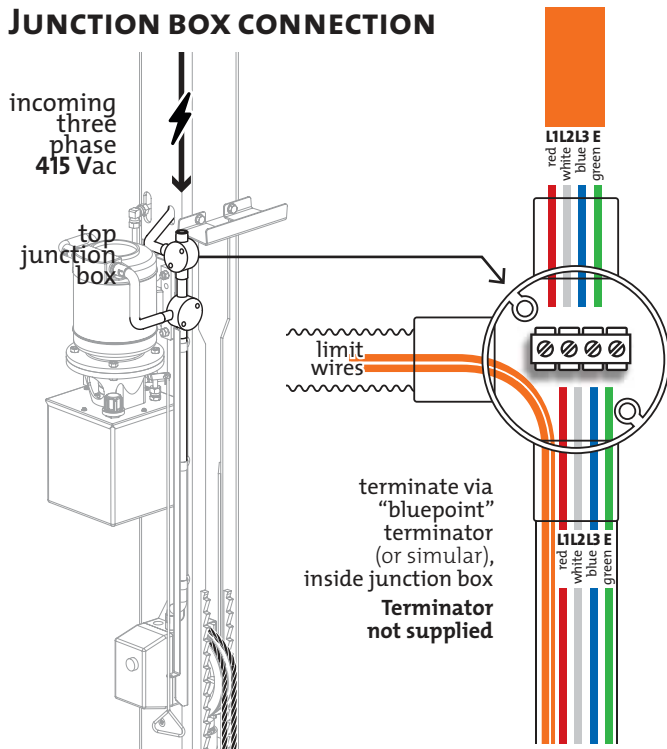

## THREE PHASE WIRING DIAGRAM

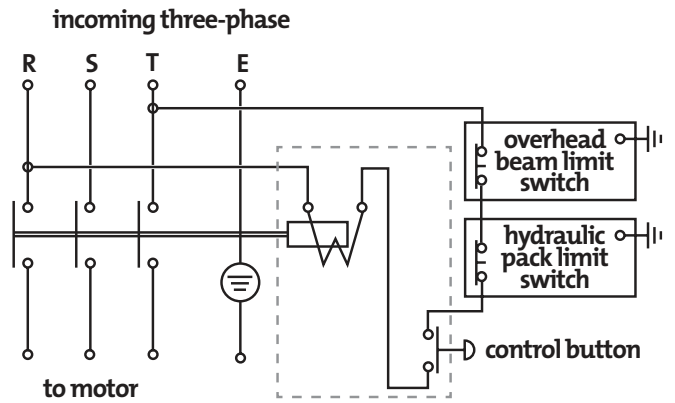

## OPTIONAL SINGLE PHASE WIRING DIAGRAM

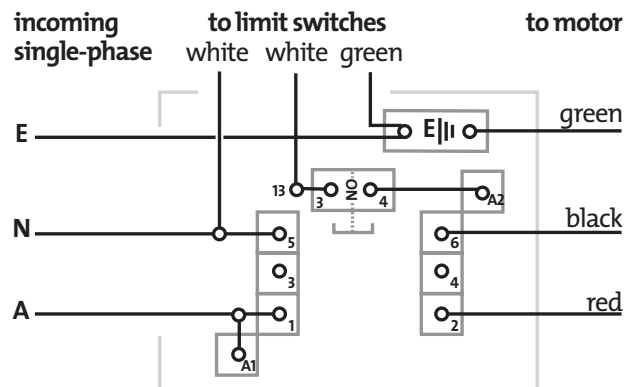

When installed, motors must be tested under full load, checking voltage at motor terminals.

## Hydraulic circuit diagram

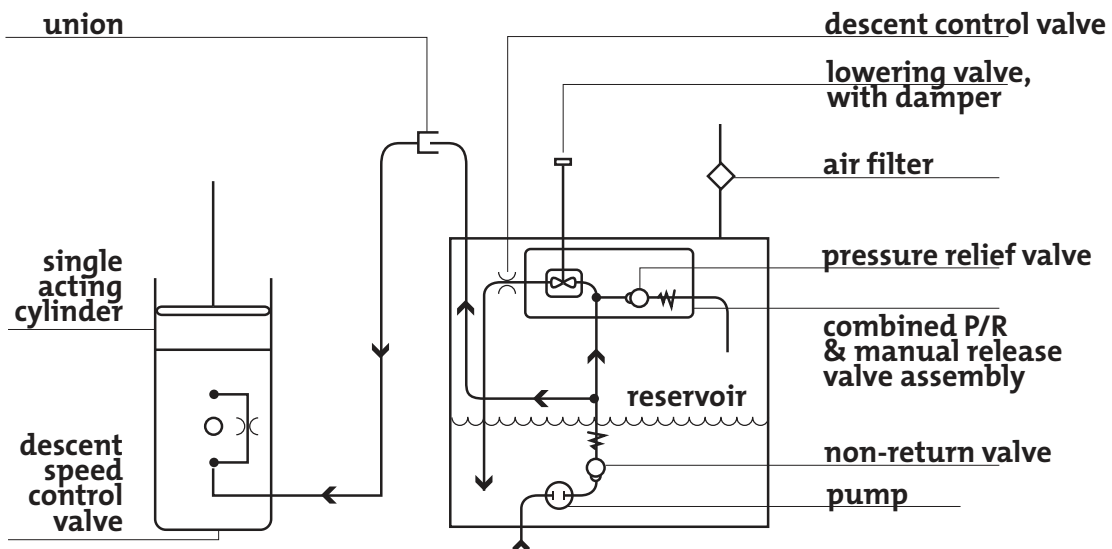



# INSTALLER CHECKLIST

## INSTALLER MUST CHECK (TICK) THE FOLLOWING LIST WHEN INSTALLING A MOLNAR HOIST

- legal clearances around hoist
- floor is suitable and within manufactures specifications
- wire ropes, pulleys and/or hoses are free of any damage
- safety devices, limit switches and controls have been checked for correct operation
- hydraulic system checked and leak free at time of installation
- hoist tested without and with load as per manufactures specifications
- hoist has been lubricated and adjusted as per manufactures specifications
- log book use has been explained to owner/operator and initial details completed
- the client representative has been shown and instructed in the correct operation and maintenance of the hoist

### DISTRIBUTOR (VENDOR)

Company \_\_\_\_\_

Branch \_\_\_\_\_

### HOIST

Installation date \_\_\_\_\_

Customer asset number \_\_\_\_\_

Serial number \_\_\_\_\_

### CLIENT REPRESENTATIVE

Name \_\_\_\_\_

Position \_\_\_\_\_

Signature \_\_\_\_\_

### INSTALLER DETAILS

Name \_\_\_\_\_

ID number \_\_\_\_\_

Signature \_\_\_\_\_

These records should be retained for administrative and warranty assistance  
Log books are available from Molnar Services or Molnar Hoists distributors



*For more information, please contact us or your local Molnar Representative*

16-20 Coglin Street Brompton SA 5007 Australia  
**T** 08 7120 8700 **F** 08 8346 0097 **E** [info@molnarhoists.com.au](mailto:info@molnarhoists.com.au)  
[www.molnarhoists.com.au](http://www.molnarhoists.com.au)

*onwards & upwards*