

*Operation and  
maintenance  
instructions for Molnars  
range of Two Post Hoists*

# TWO POST HOISTS OPERATION AND MAINTENANCE

# M O L N A R



**HOISTS**

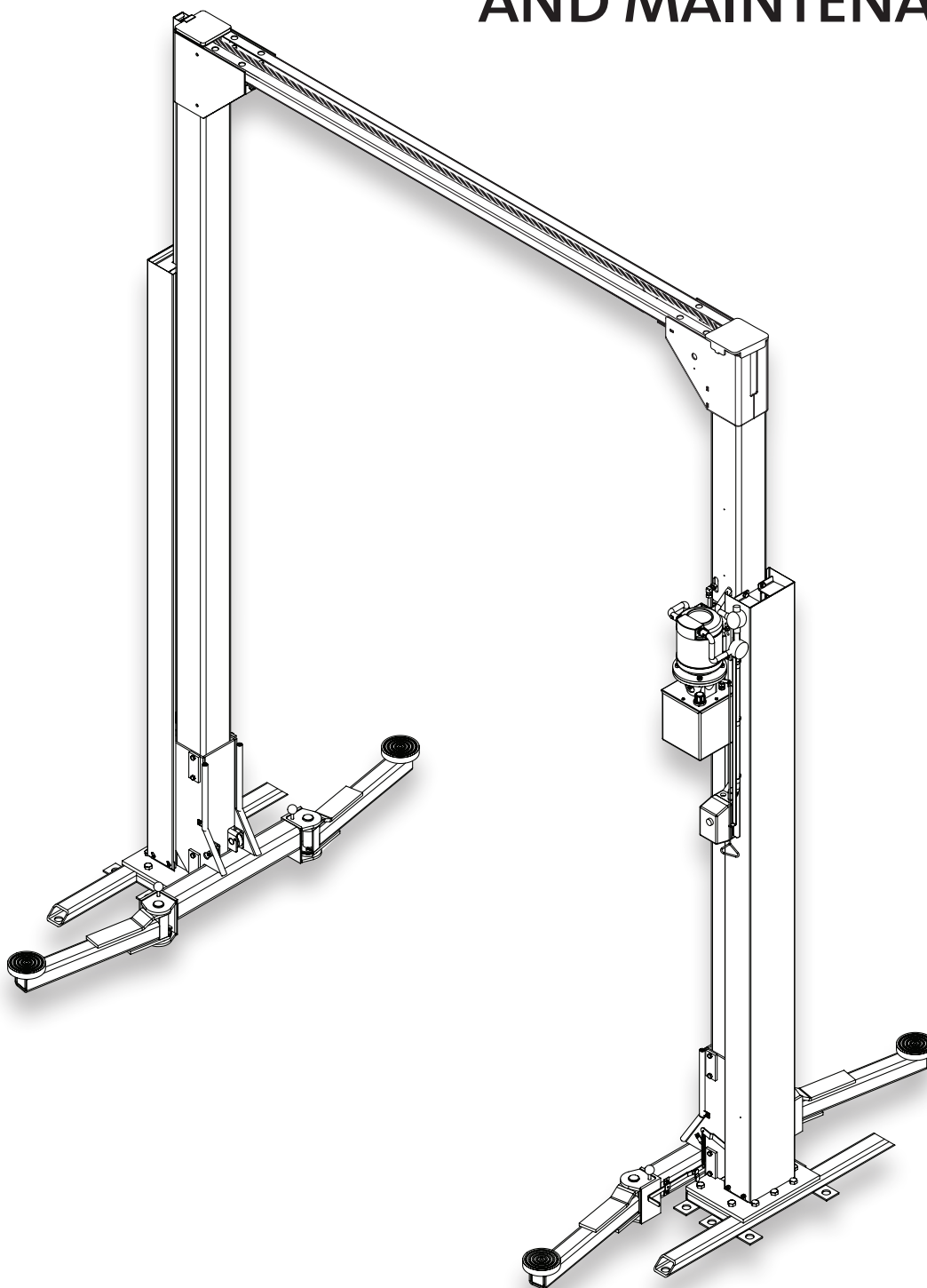

Molnar Hoists manufacture five Two Post Hoists together with a range of accessories; made in Australia and built to the highest safety standards.

Intended for use in commercial workshops, these hoists are designed to optimise workshop clear floor space for ease of access, cleaning and freedom of movement for equipment.

**BASE**

**OH**

**QL**

**AS**

**4T**





# CONTENTS

## CONTENTS

Overview	03
Safety Precautions	04
Operating	06
Maintenance	07
Owner Maintained Procedures	08
Trouble Shooting	12
Accessories	13
Warranty	14

## KEY

- General warning
- Electrical hazard

## TERMINOLOGY

From time-to-time product or process descriptions can change or evolve, for the purposes of clarity:

- cables = wire ropes
- pulleys = sheaves
- shafts = pulley pins
- safety = lock
- lift pads = pick-up pads
- release lever = lowering handle

This is owner manual 1 of 4



As the policy of Molnar Hoists is one of continuous improvement, the manufacturer reserves the right to change specifications without notice. Information is correct and true at time of printing (JULY 2012)



# OVERVIEW

	All Rounder	Base	Asymmetric	Quick Lift	4 Tonne
Number	MF1705-93-OH-3T	MF1705-85A-3T	MF1705-OH-3T-AS	MF1705-OH-3T-QL	2P4T-PREMIUM
Length	1200 mm	<	<	<	1000 mm
Width	3250 mm	<	<	<	3450 mm
Height	3860 mm	2770 mm	3860 mm	3860 mm	3890 mm
Preferred Clearance Height	150 mm above Height, for installation				
Width Between Posts	2650 mm	<	<	<	<
Width Between Carriages	2420 mm				
Maximum Raised Height	1900 mm	1900 mm	1900 mm	1855 mm	1900 mm
Minimum Lowered Height	110 mm				
Reach of Lifting Arms	610 mm min , 1020 mm max				
Wire rope	13mm diameter 6 x 29FW(14/7+7F/1) IWRC. RHOL B1770 minimum breaking strength 107kn				
Motor	3 Phase, 3 HorsePower, 415 Volt (requires 3 Phase and Earth, 5 Amp)				
Or	Single phase, 240 Volt (requires 240 Volts under load at motor, hard wired on 20 Amp circuit)				
Gross Weight	722 kg				
Lifting Capacity	3 tonnes	3 tonnes	3 tonnes	3 tonnes	4 tonnes
Minimum Lifting Time	27 seconds	<	<	<	35 seconds
Hydraulic Oil	high quality, 46 weight, anti-wear				

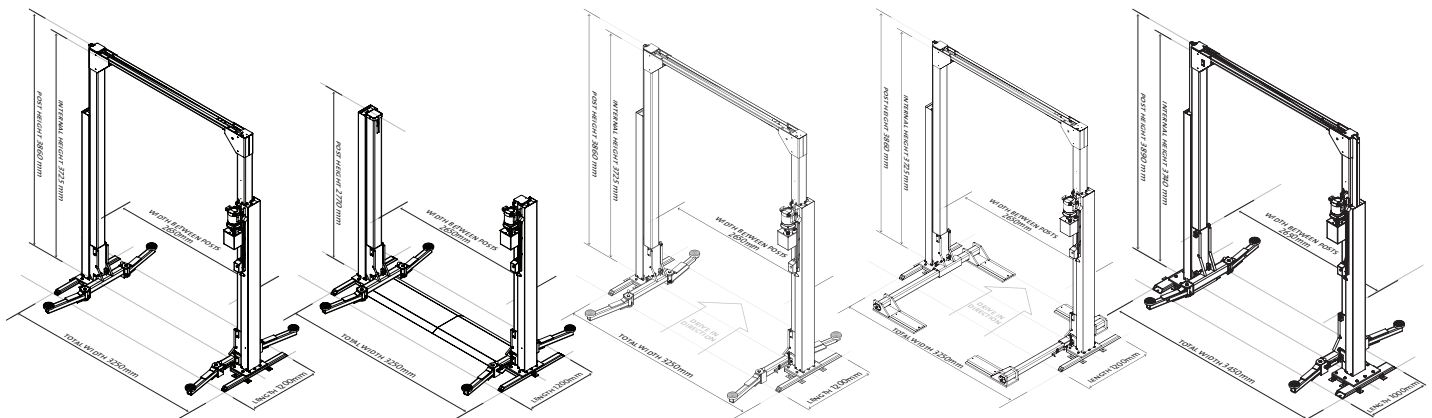



## SAFETY PRECAUTIONS

***For your own safety and the safety of equipment, always take the following precautions  
Failure to comply with these precautions may result in loss of load, damage to unit and/or personal injury***

 Ensure you carefully read and understand the operation and safety instructions detailed in this Manual before using the equipment.



 Do not make changes to safety equipment.



 Use only vehicle manufacturer's pick-up points.



 Do not oil or grease extension arms as they should not move in or out while hoist is operating.



 Monitor vehicle, hoist and area before use and during operation of hoist. Ensure area is clear of any personnel or obstructions when raising or lowering.

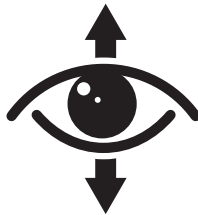

 Do not try to adjust relief valve as it has been set at maximum operating efficiency.



 Do not exceed the rated lifting capacity of the unit

3000 kilograms: All Rounder, Base, Asymmetric, Quick Lift

4000 kilograms: 4 Tonne



 Do not force safety lever into the off position while weight is resting on safety.



 Load must be locked at all times, except when raising or lowering.



 Do not attempt to operate the hoist from under vehicle



 Regular service and maintenance must be carried out as per the Maintenance requirements detailed in this Manual. Failure to do so may void warranty and cause risk of injury.



 Remove brake fluid spills immediately as this will damage the powder coat. Clean the hoist with warm water and nonabrasive pH neutral detergents. Surfaces should be thoroughly rinsed to remove residue. After floor cleaning, thoroughly rinse base of hoist to remove residue.





## SAFETY PRECAUTIONS

- Always use safety stands when removing or installing heavy components

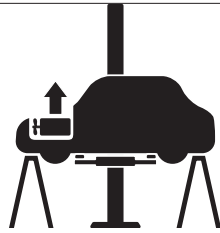

- Do not operate if damaged



- Do not load or unload unless hoist is fully lowered

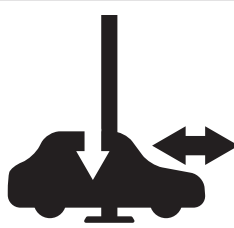

- Perform risk assessment before attempting to lift loaded vehicles

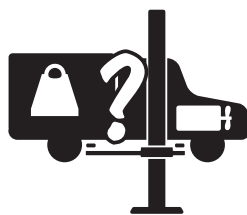

- Maximum pad load differential 60-40 %



- For asymmetric hoists, ensure the correct direction of vehicle



### MOIST CONDITIONS

- This vehicle hoist is not designed to be used in & around steam cleaning nor to be installed in the open exposed to the elements. Hoists installed under such conditions are not covered by our guarantee.



- In moist conditions, ensure moving components are well lubricated. To prevent rust in the cylinder raise the hoist to full height and leave it there when not in use overnight and on weekends. Seal all electrical conduits and switches.

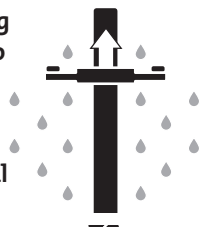

- Use only recommended wire rope lubricants





# OPERATION

## To RAISE

- 1 Centre vehicle between posts with centre of gravity midway between pick-up pads.
- 2 Identify correct pick-up points and position four support pads, ensuring contact (two at front; two at rear).
- 3 Ensure LOCK lever is ON.
- 4 **Hold down CONTROL button to raise vehicle to required height.**

During lift, the auto load hold lock will 'click'. If you do not hear a clicking sound, STOP hoist immediately by releasing CONTROL button. Do not operate hoist until it has been inspected by an authorised service agent.

## To LOWER

- 1 Hold down CONTROL button and raise hoist approximately 50mm.
- 2 Move LOCK lever to OFF to disengage load hold lock.
- 3 **Pull down on LOWERING handle to lower hoist.**

## To LOCK

- 1 Release CONTROL button to stop hoist at desired height.
  - 2 Pull down on LOWERING handle to lower hoist until load hold lock engages and load is supported.
- Hoist will auto stop at maximum height. You must lock hoist before commencing work at any height.

## To UNLOCK

- 1 Hold down CONTROL button and raise hoist approximately 50 mm
- 2 Move LOCK lever to OFF position to disengage load lock

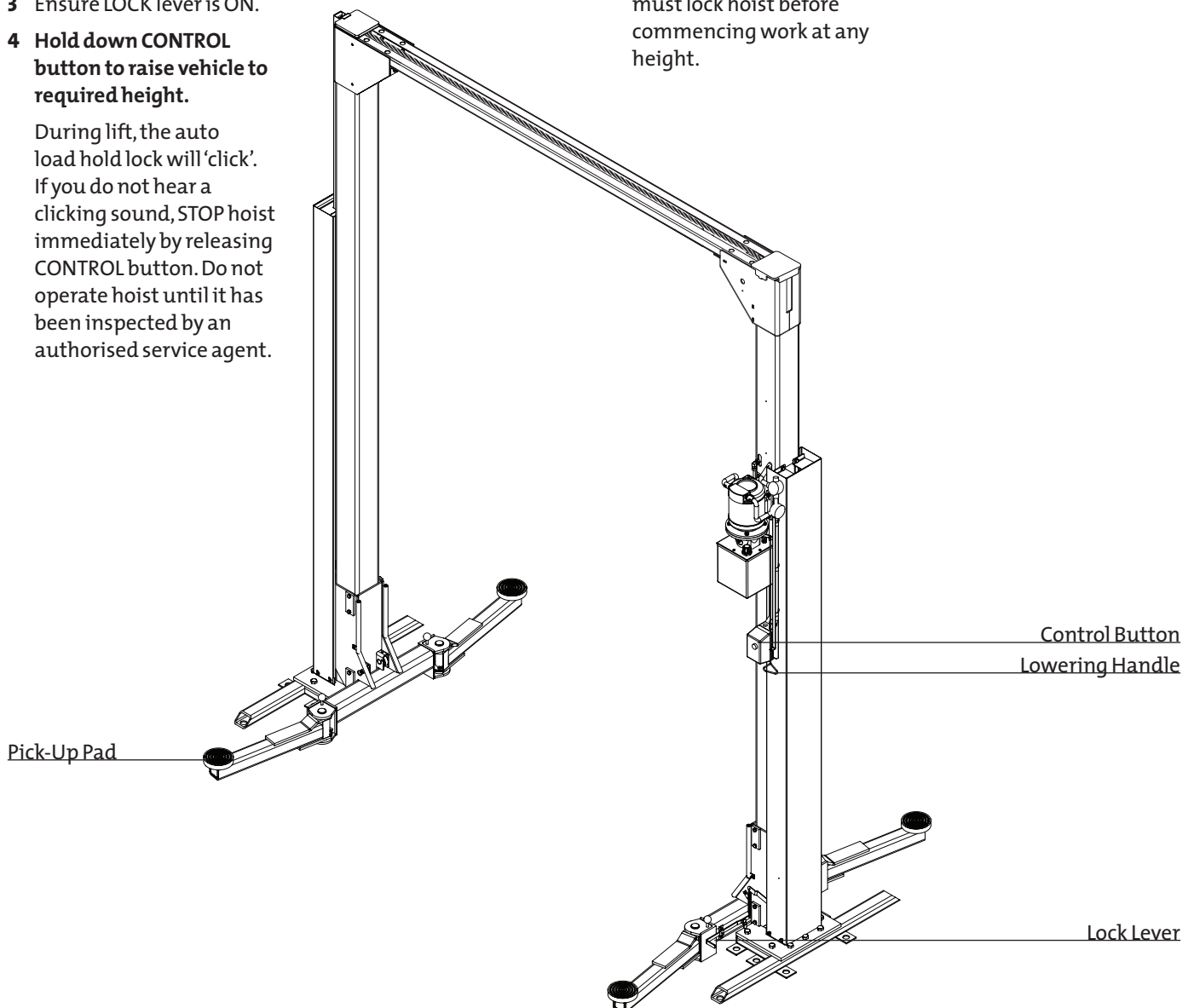



# MAINTENANCE

## OWNER MAINTAINED - *described in this Manual*



It is the Hoist Owner's responsibility and Duty of Care to maintain the hoist. This must be recorded and retained.



### DAILY

- Visual Inspection
  - Access & clearance
  - Work area clean & tidy
  - Structure
  - Loose or damaged parts
  - Decals & control markings
  - Hydraulic fluid levels
  - Pick up pads
- Functional Inspection
  - Operating controls
  - Safety mechanism**
  - Unusual noise or vibration
  - Hydraulic system leaks
- Check Accessories



### MONTHLY

- Isolation points
- Flooring
- Anchor bolts
- Structural alignment
- Structural integrity
- Visual appearance
- Displayed notices
- Compliant clearance
- Safety mechanism
- Pick up pads
- Limit switches
- Wire ropes
- Check accessories
- Lubrication
- Pulleys



### SIX MONTHLY

- Additional checks (on top of Monthly check)
- Oil leaks from cylinder
  - Oil leaks at pipe joints
  - Anchor bolts

## SERVICE PROFESSIONAL - *described in Service Manual*



Service and safety inspection on the hoist must be performed by a competent person. This must be recorded and retained.



### AFTER 6 WEEKS

- The first oil change should occur within the first three months of operation (to remove any contaminants flushed through the system).
- change the hydraulic oil
  - readjust long cable and arm locks



### ANNUALLY

- If the 12 monthly service and safety inspection is not performed, the warranty is null and void.
- Safety operation test
  - Wire rope safety test
  - Check carriage rollers
  - Lubricate pulleys
  - Wire Ropes
  - Lift arms, pivot pins, pick-up pads
  - Hydraulic oil and system
  - Electrical, controls and travel limits
  - Structural & general check
  - Accessory conditions



### 2 YEARLY

- To keep the hydraulic system (pump, seals, valves) in good working condition, oil changes are required every two years to ensure any degraded or contaminated oil is cleaned out of the system.
- Replace hydraulic oil
  - Clean tank and filter

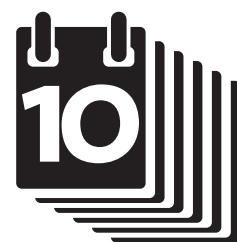

### 10 YEARLY

- After 10 years of service, remove Wire Ropes and pulleys from hoist. Clean and inspect to ascertain serviceability, replace if required. It is recommended that pulley bushes be replaced at this time. If the hoist is in a high working or extreme environment the Wire Ropes should also be replaced.
- Replace pulley bushes
  - Replace wear pads
  - Replace pick-up pads
  - Wire Ropes & pulley removal and inspection



## OWNER MAINTAINED

### DAILY VISUAL INSPECTION

**ACCESS & CLEARANCE:** Ensure there are no obstructions around the hoist (or vehicles when on the hoist) that could prevent operators working safely on and around the hoist and vehicle.

**WORK AREA CLEAN & TIDY:** The work area should be clean and tidy prior to operation to eliminate the risk of slips and trip hazards, i.e. oil, parts, tools, hoses, etc.

**STRUCTURE:** A visual inspection of the structure for anomalies that may indicate damage or deterioration. Anomalies must be reported to the authorised person. Only an authorised person may assess the condition of the structure. The result of this assessment must be reported and recorded.

**LOOSE OR DAMAGED PARTS:** A visual inspection of hoist components for anomalies that may indicate parts are damaged or loose. The result of this assessment must be reported and recorded.

**DECALS & CONTROL MARKINGS:** Check to see that the hoist's decals and markings for controls are not only present, but are in a good, clean condition and clearly visible.

**HYDRAULIC FLUID LEVELS:** Check the amount of hydraulic fluid in the system is within the correct limits.

**PICK UP PADS:** Where used, check condition of pick up pads to ensure they are clean, the material and structure is in good condition, and not excessively worn or otherwise damaged.

**ARM LOCKS ARE FUNCTIONING CORRECTLY**

### DAILY FUNCTIONAL INSPECTION

**OPERATING CONTROLS:** Operating controls should be tested by activating through the full range of operation.

**UNUSUAL NOISE OR VIBRATION:** If during operation, unusual noise or vibration is detected, it must be reported and treated as a potential fault.

**HYDRAULIC SYSTEM LEAKS:** After the operational check, the areas of the hydraulic circuit must be inspected for leaks. Evidence of fluid on the hoist can be a sign of a potential fault.

**ACCESSORIES:** Accessories should undergo the same inspection as the hoist.

### DAILY CHECK SAFETY MECHANISM

- 1 Raise hoist up to 200mm from floor.
- 3 Switch LOCK lever to OFF position and ensure it remains in position.
- 4 Lower hoist to ground to check that the safety LOCK lever resets to the ON position.

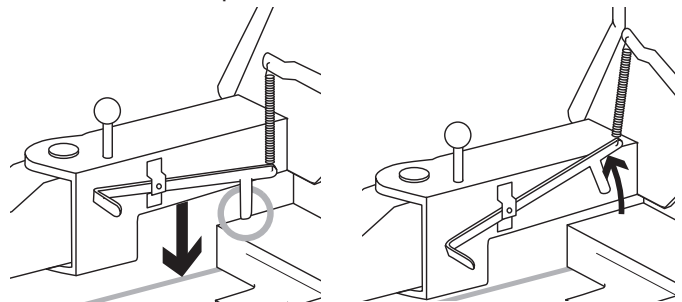

 If safety mechanism does not operate properly, do not operate hoist until it has been inspected by an authorised service agent.



# OWNER MAINTAINED

## MONTHLY INSPECTION

**ISOLATION POINTS:** Are there appropriate isolating points to allow the hoist to be safely isolated and locked out to prevent accidental or unwanted operation.

**FLOORING:** Check condition of floor area where the hoist is mounted, i.e. is not cracked or crumbling, especially in the region surrounding mounting bolts.

**ANCHOR BOLTS:** Check the anchor bolts are secure in the concrete, the bolts are tight and are not excessively corroded or otherwise deteriorated or damaged.

 There is significant difference between a “Base Bolt” and an “Anchor Bolt”. Please familiarise yourself with the respective bolt location before adjusting or servicing bolts.

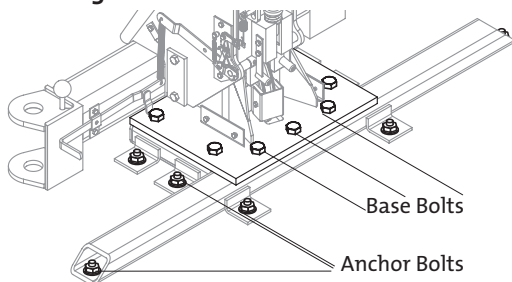

**STRUCTURAL ALIGNMENT/ INTEGRITY:** Visually check the physical condition of the structural components for damage, deformation, corrosion or any other signs of deterioration.

**VISUAL APPEARANCE:** Check the overall appearance of the hoist for damage, signs of deterioration or other potential indicators of faults or hazards.

**OPERATOR’S MANUAL AVAILABLE:** The operator’s manual for the hoist must be available, in good condition and easily accessible to operators.

**DISPLAYED NOTICES:** Critical hoist information needs to be displayed on the hoist clearly, easily visible and legible for operators.

**RATED CAPACITY** is the safe working limit of the hoist.

**LOAD DISTRIBUTION** is how vehicles should be loaded safely on a hoist.

**OPERATING INSTRUCTIONS** detail how to safely operate the hoist.

**COMPLIANT CLEARANCE:** Ensure there are no temporary or permanent obstructions around the hoist or vehicles when on the hoist, that encroach into the safe area clearance limits.

**LIMIT SWITCH:** Ensure that limit switches prevent operation of the hoist beyond the limits of travel.

**WIRE ROPES:** The wire ropes must be visually checked for signs of deterioration and if necessary cleaned and re-lubricated.

**LUBRICATION:** All lubrication points must be inspected and re-lubricated as required.

**ACCESSORIES:** Accessories should undergo the same inspection as the hoist.

**PULLEYS:** Visually check rotation during raising and lowering of hoist

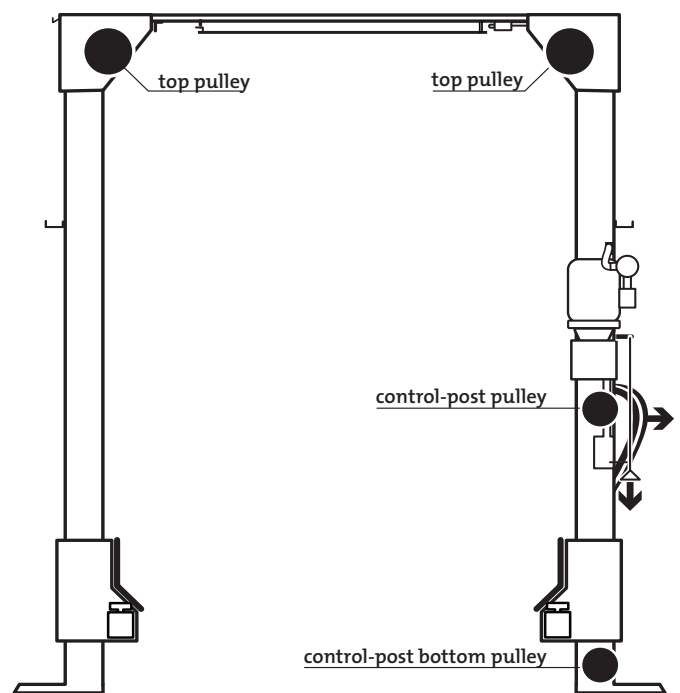

 If pulleys are not rotating freely, pulleys must be removed/inspected/replaced by an authorised service agent.



# OWNER MAINTAINED

## MONTHLY - WIRE ROPE INSPECTION

- 1 Loosen the 4 M6 bolts securing the covers to the posts, lift and remove
- 2 Visually inspect wire ropes for wear, corrosion, deformities and fractures with the hoist fully lowered.
- 3 Repeat with the hoist fully raised

 **if any damage is found to the wire ropes contact an authorised service agent for further investigation.**

**Wire rope must be replaced if:**

- A** At any point the visible number of broken wires exceeds 7 wires in 78mm length of rope or 14 wires in 390mm length of rope.
- B** The number of broken wires is likely to exceed the above measure by the next service.
- B** A strand of wire is broken.
- C** A rope has been physically damaged by crushing or deforming.
- D** If there are any inconsistent areas. If inconsistency is found, it should be replaced or referred to a wire-rope specialist for inspection.

 **Wire ropes must be inspected by a COMPETENT person. Wire ropes should be replaced by an authorised service agent.**

## MONTHLY LUBRICATION PROCEDURES

- 1 Wipe grease or lubricant from  
→ outer roller tracks  
→ inner roller tracks  
→ side wear tracks  
on both posts, with a cloth

- 2 Apply lubricant to  
→ inside roller tracks  
→ side wear tracks  
on both posts with Dry Spray Lubricant

- 3 Grease Outer Roller Tracks with Marine grade wheel bearing grease

Outer roller tracks can be heavily lubricated as the outer tracks are fully covered by the Hoist covers.

- 4 Lubricate the safety mechanism and linkages with spray lubricant. Check operation by raising and lowering.

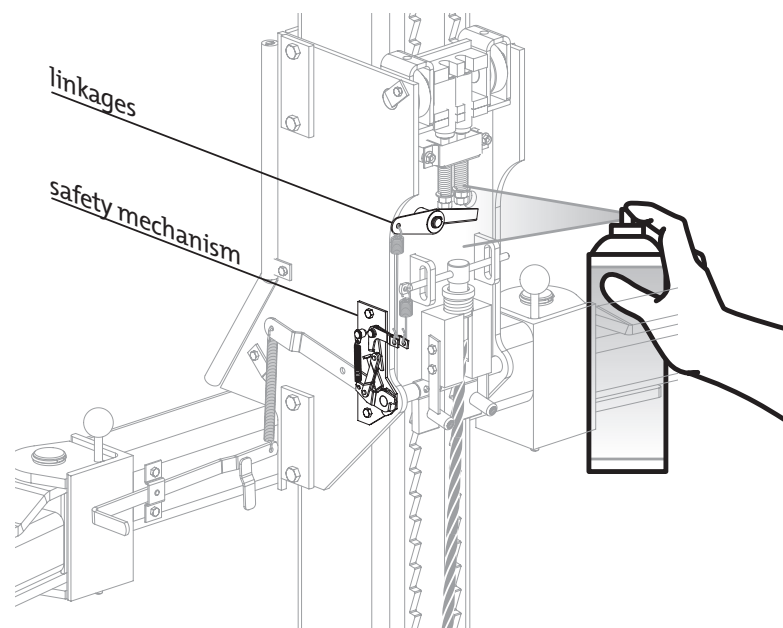
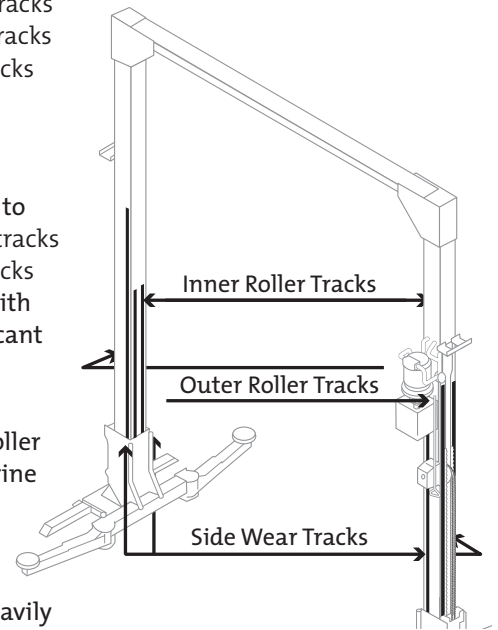



# OWNER MAINTAINED

## MONTHLY CHECK SWIVEL ARMS

### 1 Wear Pads

- Raise hoist to waist height.
- Check free play in carriages by rocking the carriages sideways. There should be 1-2mm of movement.

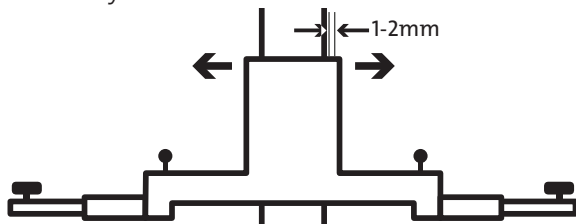

- If there is excessive movement, side wear pads will need to be replaced.

### 2 Arm Extension

- Pull arms out to ensure that Extension stops are in place.



- If arms pull out of the carriage **or** do not pull out at all, arms will need to be replaced.

### 3 Auto Arm Lock

- Check that there isn't excessive vertical movement at the Arm Lock.

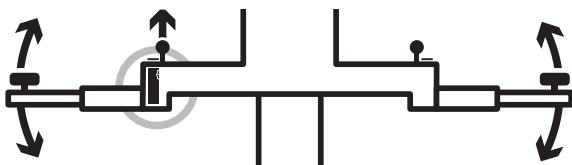

- Check that the circlip on the pivot pin is in place.
- Check that the split pin is still in place in the pivot pin.
- Raise the Lift Rod and disengage lock mechanism to check smooth movement of arms.

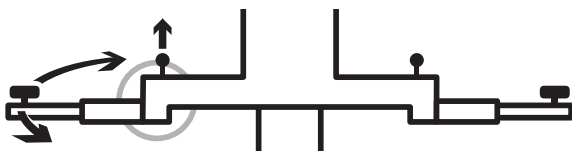

- Raise the Lift Rod, position arm in normal operating position, release lift rod and apply side force to the arm. Ensure the lock remains engaged
- Visually inspect that the locking teeth are in good condition.
- Lower hoist to the ground and test the Auto Release.

### 4 Pick-Up Pads

- Check that pads screw up and down freely.
- Check that the thread is not worn, that there isn't excessive rocking.
- Check that the retention washer and circlip is in place at the bottom of the pad shaft, so that the pads can not screw out.
- Ensure that the rubber of the pad is in good condition; remains pliable and soft and the grooves in the Pad are visible.

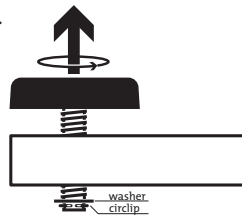

If there is an issue with **Wear Pads, Arm Extensions and/or Auto Arm Lock**, they should be inspected, adjusted and/or replaced by an authorised service agent.

## SIX MONTHLY CHECK - OIL LEAKS

- 1 Check for oil leaks from cylinder. Visual inspection. If leaks are detected, remove and replace cylinder.
- 2 Check for oil leaks around pipe joints at post and oil tank. Visual inspection. If leaks are detected, tighten oil fittings.



Hydraulic repairs should be performed by an authorised service agent.

## SIX MONTHLY CHECK - ANCHOR BOLTS

- 1 Rock the hoist to check for ANY movement
- 2 Use a spirit level to ensure posts are vertical in both axis
- 3 Visually inspect anchor bolts
- 4 Tighten anchor bolts manually
- 5 Check that the Shimming of the Hoist is secure and in good condition.















## TROUBLE SHOOTING

<b>Q</b>	<b>!</b>	<b>A</b>
<b>Knocking noise during raising or lowering</b>	Roller tracks dry	Remove covers and grease outer roller tracks, lubricate inner wear tracks with dry lubricant
<b>Shuddering or shaking during raising or lowering</b>	Wear pads sticking	Apply dry lube on slide wear tracks
	Roller bushes dry	Remove rollers and grease bushes
<b>Hoist not staying up</b>	Sticking lowering handle	Lube pivot on handle
	Contaminated oil	Change oil
	Faulty control valve	Replace control valve
	Bent lowering handle	Replace or straighten lowering handle
<b>Motor will not run</b>	No power supply	Check circuit breakers
	Stuck limit switch	Check operation of both limit switches
	Faulty contactor	Replace contactor *
<b>Motor runs but will not lift</b>	Phase rotation	Check and change rotation of motor *
	Lowering valve open	Close valve
	Hoist overloaded	Remove vehicle
<b>Vehicle leans towards Non-Control- Post</b>	Wire Rope stretched	Remove cover and adjust Wire Rope
<b>Oil leaks</b>	Loose fittings	Tighten fittings
	Faulty Fittings	Replace fittings
	Ram seal	Replace seal
<b>Safety not releasing</b>	Hoist not raised	Raise hoist
	Damaged mechanism	Replace mechanism
<b>Safety not staying off</b>	Dry pivots in mechanism	Lube pivots
	Damaged mechanism	Replace mechanism
<b>Hoist will not go to top</b>	Low in oil	Top-up oil

\* Qualified electrician only



## ACCESSORIES

<p><b>EP10</b> EXTENSION PAD</p>		<p>Provides valuable extra clearance for four-wheel-drives and vans</p>	<p>Length 160 mm Width 160 mm Height - min 180 mm Height - max 225 mm</p>	<p>OH 4T AS BASE</p>
<p><b>J3AB</b> STABILISER PAD</p>		<p>Auxiliary support for stability Made from solid, long-lasting vulcanised rubber</p>	<p>Diameter 100 mm Pad Height 30 mm</p>	<p>OH 4T AS BASE</p>
<p><b>JJ3</b> PICK UP PAD, LARGE</p>		<p>Supports and stabilises vehicle</p>	<p>Diameter 140 mm Height - min 30 mm Height - max 80 mm</p>	<p>OH 4T AS BASE</p>
<p><b>J3</b> PICK UP PAD, SMALL</p>		<p>Supports and stabilises vehicle</p>	<p>Diameter 100 mm Height - min 30 mm Height - max 80 mm</p>	<p>OH 4T AS BASE</p>
<p><b>QLSB-02</b> QUICK LIFT BEAM</p>		<p>Provides more pick-up options</p>	<p>Length 1550 mm Width 270 mm Height 110 mm</p>	<p>QL</p>
<p><b>EXT-PAD</b> BEAM RISER, STANDARD</p>		<p>Provides valuable extra clearance for four-wheel-drives and vans</p>	<p>Length 120 mm Width 100 mm Height - min 170 mm Height - max 215 mm</p>	<p>QL ON QLSB-02</p>
<p><b>EXT-PAD-LOW</b> BEAM RISER, LOWERED</p>		<p>For vehicles with low clearance</p>	<p>Length 120 mm Width 100 mm Height - min 140 mm Height - max 175 mm</p>	<p>QL ON QLSB-02</p>
<p><b>AXLE-PU</b> BEAM RISER, AXLE</p>		<p>For stable pick-up on axle; cradle head prevents lateral movement</p>	<p>Length 120 mm Width 100 mm Height - min 150 mm Height - max 205 mm</p>	<p>QL ON QLSB-02</p>
<p><b>J3BP</b> BEAM PAD</p>		<p>Stabilises vehicles on beams Made from solid, long-lasting vulcanised rubber</p>	<p>Diameter 90 mm Pad Height 30 mm</p>	<p>QL ON QLSB-02</p>
<p><b>PL92-RB</b> RUBBER BLOCK, STANDARD</p>		<p>Solid rubber block for cushioned lifting For use on Rubber Block Nest</p>	<p>Length 150 mm Width 100 mm Height 70 mm</p>	<p>QL ON QLSB-02</p>
<p><b>PL92-RB-40</b> RUBBERBLOCK, LOWPROFILE</p>		<p>For vehicles with low clearance For use on Rubber Block Nest</p>	<p>Length 150 mm Width 100 mm Height 40 mm</p>	<p>QL ON QLSB-02</p>
<p><b>SLO2-NEST</b> RUBBER BLOCK NEST</p>		<p>Nest to house rubber blocks</p>	<p>Length 160 mm Width 100 mm Height 120 mm</p>	<p>QL ON QLSB-02</p>



*For more information, please contact us or your local Molnar Representative*

16-20 Coglin Street Brompton SA 5007 Australia  
**T** 08 7120 8700 **F** 08 8346 0097 **E** [info@molnarhoists.com.au](mailto:info@molnarhoists.com.au)  
[www.molnarhoists.com.au](http://www.molnarhoists.com.au)

*onwards & upwards*