

# QUICK LIFT

## 3 TONNE TWO POST HOIST

### MF1705-OH-3T-QL

# M O L N A R

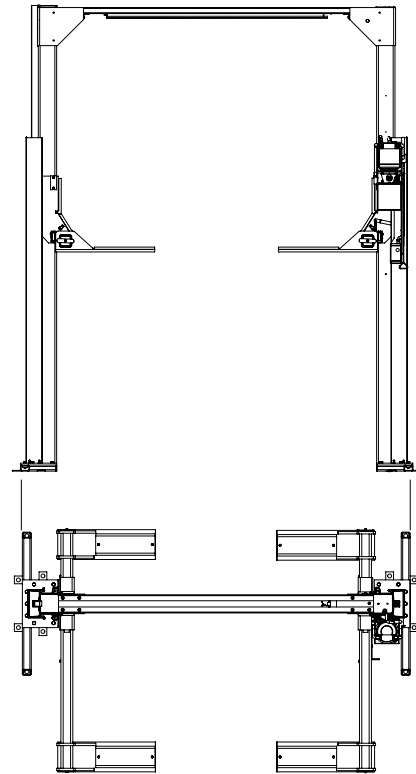
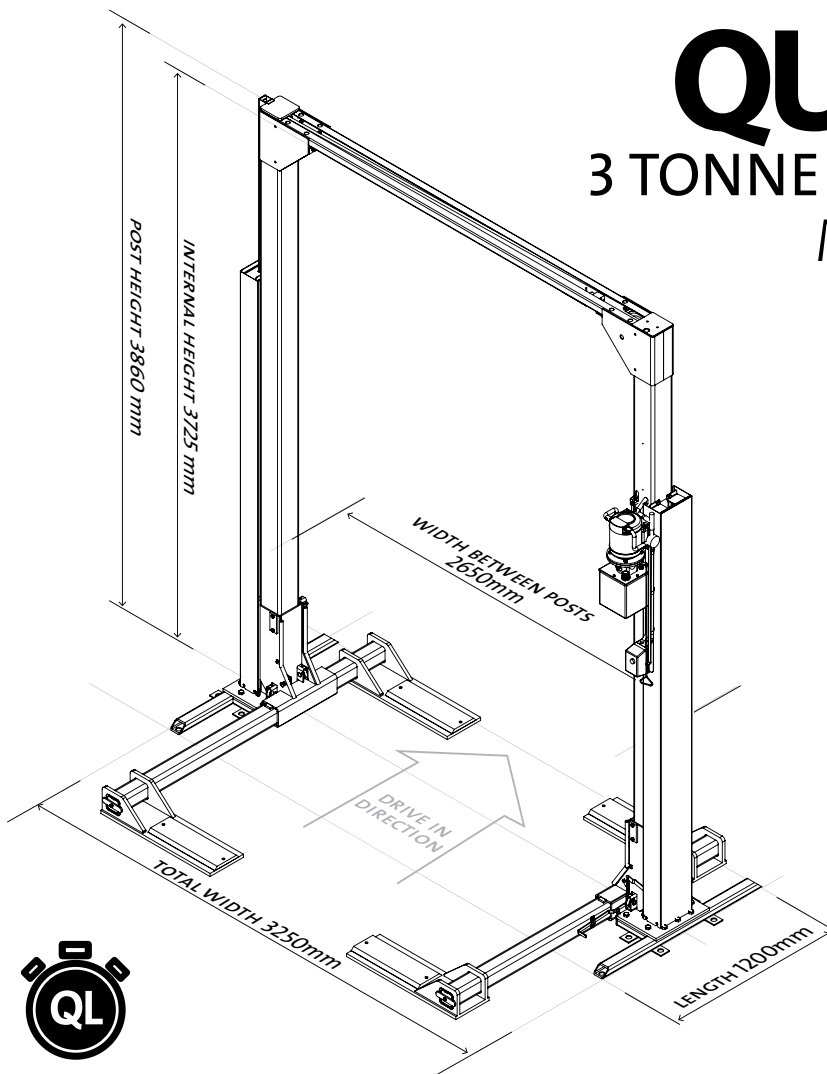

#### PRODUCT SPECIFICATIONS

Footprint	3250 x 1200 mm
Length	1200 mm
Width	3250 mm
Height	3850 mm ♦
Preferred Clearance Height	150 mm above Height, for installation
Height to Beam	3725 mm
Width Between Posts	2650 mm
Width Between Carriages	2420 mm
Maximum Raised Height	1830 mm
Minimum Lowered Height	45 mm
Reach of Lifting Pads	308 mm min., 810 mm max.
Distance Between Pads	785 – 2020 mm apart
Motor	3 Phase, 3 HorsePower, 415 Volt * (requires 3 Phase and Earth, 5 Amp)
Lifting Capacity	3 tonnes
Minimum Lifting Time	27 seconds
Concrete Depth	min 100 mm, mesh reinforced, min strength 25 MPa
Hydraulic Oil	high quality, 46 weight, anti-wear
Gross Weight	722 kg
Shipping Dimensions	1.2 x 0.6 x 4.1 metres
Finish	powder coated for added durability
Warranty	3 years

#### FEATURES

Operational	push button to lift; handle to lower
	soft foam door buffers on carriage
	clear floor access
	rubber blocks included standard (PL92-RB)
	<b>single drive-in direction only</b>
Safety	deadman controls (automatic stop when released)
	safety sensor bar (automatic stop when touched)
	protection for cable breakage, overload and hydraulic failure
	meets Australian Standard AS/NZ1418.9:1996
Service & Installation	comprehensive service manuals and installation instructions included

#### CUSTOMISATION

Height	♦ different post heights available:	Micro	3300 mm
		Small	3500 mm
		Medium	3600 mm
		High	4200 mm
Colour	extensive range of powder coated colours available		
MF1705-OH-3T-QL-240VOLT *	optional single phase, 240 Volt motor (requires 240 Volts under load at motor, hard wired on 20 Amp circuit)		

#### OPTIONAL ACCESSORIES

QLSB-02	Quick Lift Beam (provides more pick-up options)
PL92-RB-40	Rubber Block, Low Profile (for low profile vehicles)
SL02-Nest	Rubber Block Nest
EXT-PAD	Beam Riser, Standard (for extra clearance)
EXT-PAD-LOW	Beam Riser, Lowered (for low profile vehicles)
AXLE-PU	Beam Riser, Axle (for stable axle pick-up)

As the policy of Molnar Hoists is one of continuous improvement, the manufacturer reserves the right to change specifications without notice.

For more information, please contact  
us or your local Molnar Representative

T 08 7120 8700 F 08 8346 0097  
E sales@molnarhoists.com.au  
www.molnarhoists.com.au

**onwards & upwards**

